

INSTALLATION INSTRUCTIONS

HDX DROP STEP



APPLICATION:

2005-2019 Toyota Tacoma Double Cab

2005-2019 Toyota Tacoma Access Cab

PART NUMBER:

56-12675, 56-12775, 56-127752

CONTENT			
ITEM	QUANTITY	DESCRIPTION	TOOLS NEEDED
1	2	STEP BAR ASSEMBLY	13MM SOCKET
2	1	FRONT DRIVER SIDE MOUNTING BRACKET	13MM WRENCH
3	4	MOUNTING BRACKET B	RATCHET
4	12	LONG M8 HEX HEAD CAP SCREW (YELLOW ZINC)	TORQUE WRENCH
5	24	M8 SPLIT LOCK WASHER (YELLOW ZINC)	RATCHET EXT.
6	24	M8 FLAT WASHER (YELLOW ZINC)	SCREWDRIVER
7	12	SHORT M8 HEX HEAD CAP SCREW (YELLOW ZINC)	
8	1	FRONT PASSENGER SIDE MOUNTING BRACKET	

ANTI-SEIZE LUBRICANT MUST BE USED ON ALL STAINLESS STEEL FASTENERS TO PREVENT THREAD DAMAGE AND GALLING

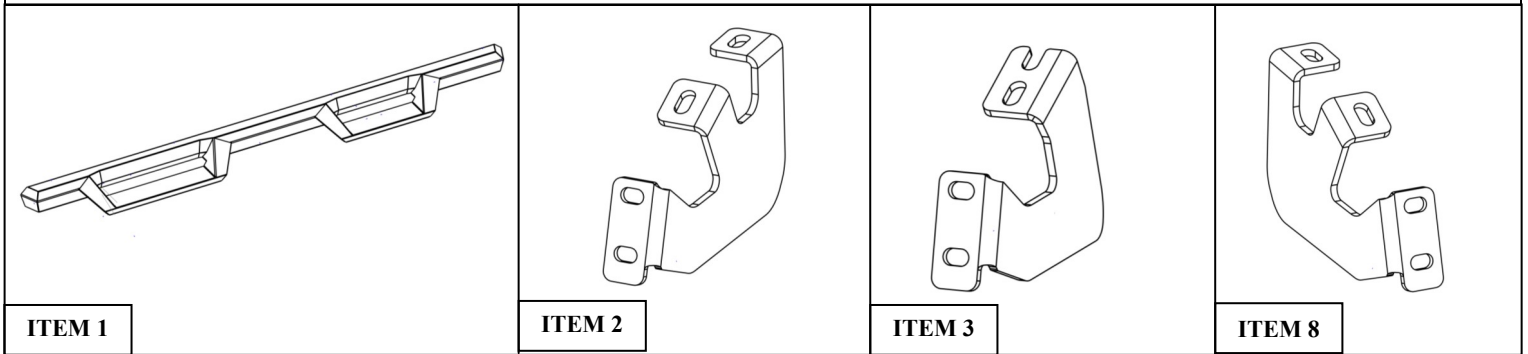

ITEM 1

ITEM 2

ITEM 3

ITEM 8

PROCEDURE

1. Remove contents from box, verify if all parts listed are present and free from damage.
Carefully read and understand all instructions before attempting installation.
Failure to identify damage before installation could lead to a rejection of any claim.

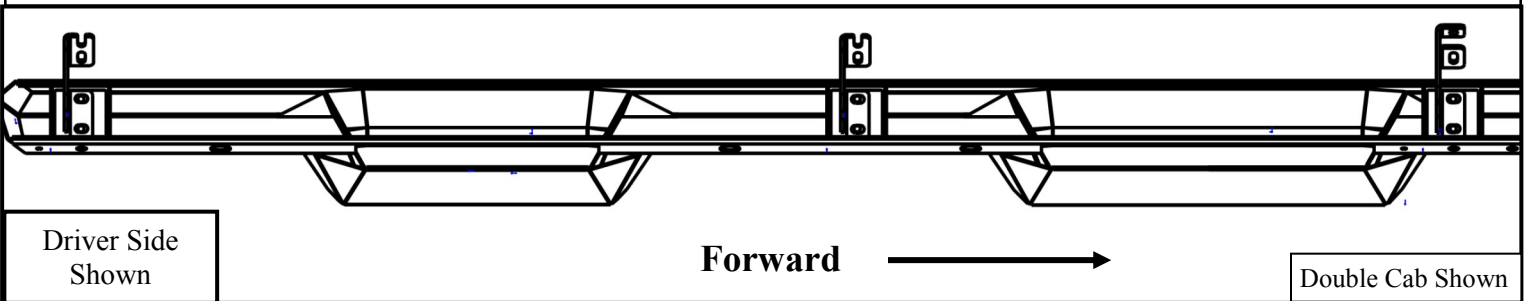

Driver Side
Shown

Forward →

Double Cab Shown



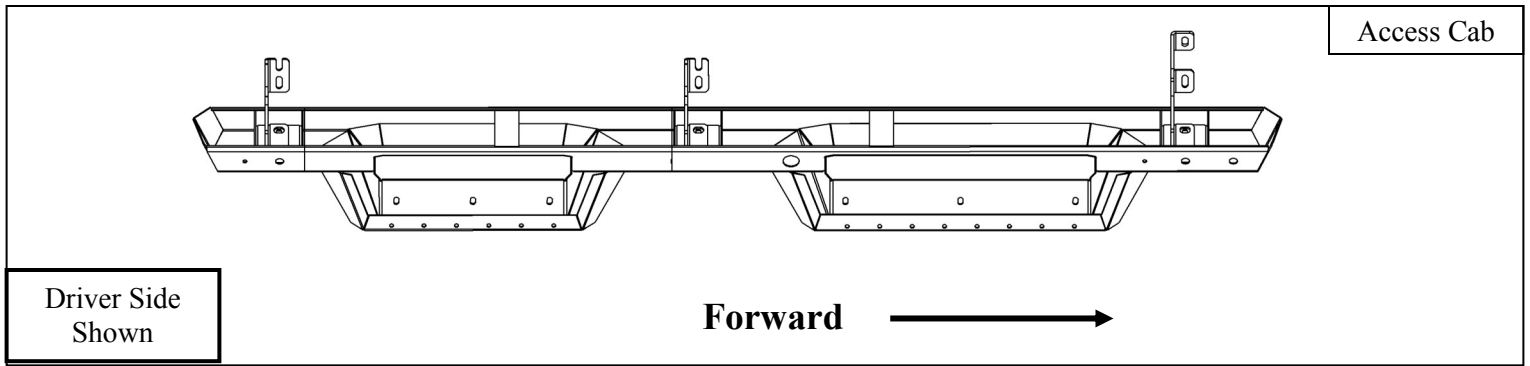

2. Start installation on either side of the vehicle. Locate mounting locations with factory threaded holes with caps covering them. Remove factory caps from threaded holes, they will not be used again. Locate (1) Front Mounting Bracket and loosely install it to the front mounting location on the rocker panel using (2) Long M8 hex head cap screw, (2) M8 split lock washer, and (2) M8 flat washer (Items 4-6). Locate the Mounting Bracket B (Item 3) and loosely secure in the correct mounting locations on the rocker panel. Loosely install using the provided M8 hardware (Items 5-7). **See Figure. 1 and 2.**
3. Repeat Step 2 for the other vehicle side.

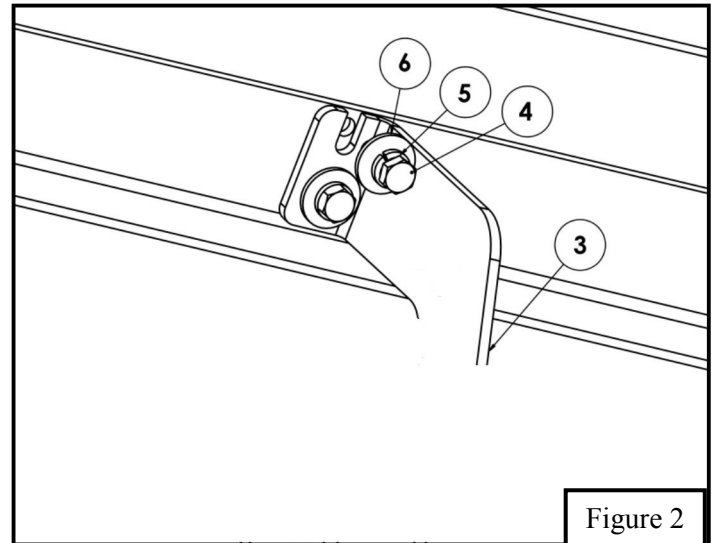
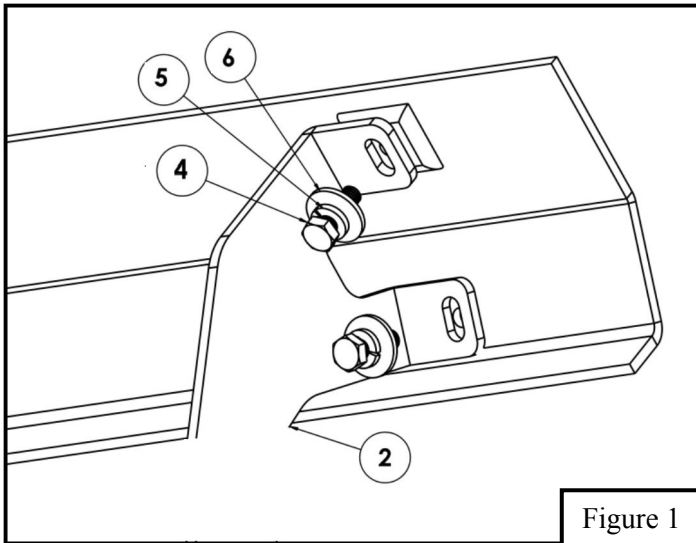

4. For Step Board installation tilt board at angle to mount to brackets. **See Figure 3.**
5. For Step Board installation to the previously installed mounting brackets use the supplied Short M8 bolts and M8 hardware. **See Figure 4.**
6. Align step board and brackets to desired positioning then torque and tighten all: M8 hardware to 20 ft-lbs.

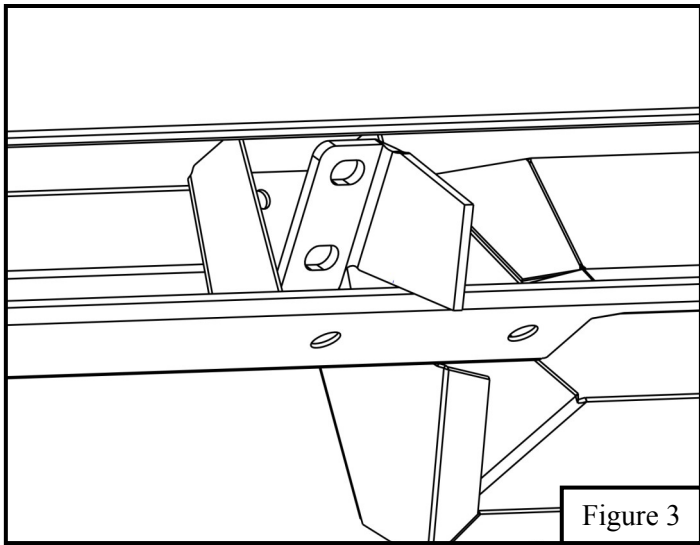

Figure 3

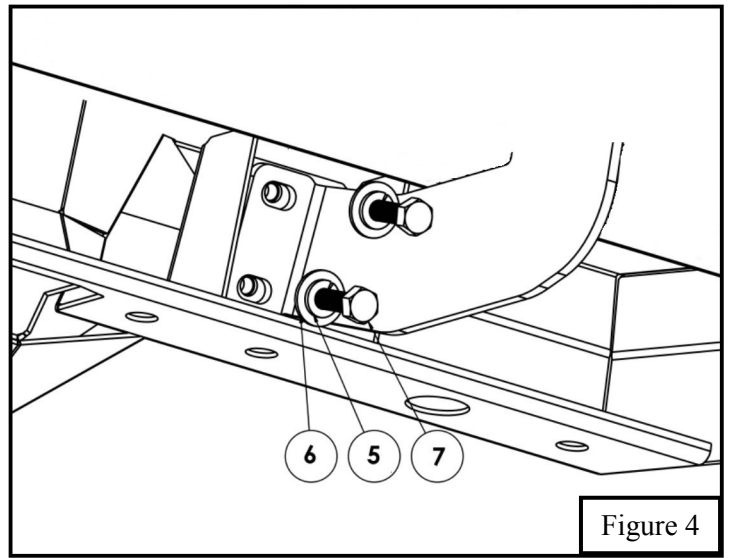

Figure 4



Care Instructions

- REGULAR WAXING IS RECOMMENDED. DO NOT USE ANY TYPE OF POLISH OR WAX THAT MAY CONTAIN ABRASIVES.
- STAINLESS STEEL PRODUCTS CAN BE CLEANED WITH MILD SOAP AND WATER. STAINLESS STEEL POLISH SHOULD BE USED TO POLISH SMALL SCRATCHES.
- GLOSS BLACK FINISHES SHOULD BE CLEANED WITH MILD SOAP AND WATER.