

APPLICATION:

Chevrolet/GMC - Silverado/Sierra 1500 Crew Cab 2004-2013; 25/3500 2001-2019 (Body Mount),
 Chevrolet/GMC - Silverado/Sierra 1500 Ext Cab 1999-2013; Ext/Double Cab 2001-2019 (Body Mount)

PART NUMBER:

56-11685, 56-116852, 56-11955, 56-119552

ITEM	QUANTITY	DESCRIPTION	TOOLS NEEDED
1	2	STEP BAR ASSEMBLY	13MM SOCKET
2	1	DRIVER SIDE FRONT MOUNT BRACKET	13MM WRENCH
3	1	PASSENGER SIDE FRONT MOUNT BRACKET	14MM SOCKET
4	1	DRIVER SIDE CENTER MOUNT BRACKET	14MM WRENCH
5	1	PASSENGER SIDE CENTER MOUNT BRACKET	15MM SOCKET
6	1	DRIVER SIDE REAR MOUNT BRACKET	15MM WRENCH
7	1	PASSENGER SIDE REAR MOUNT BRACKET	RATCHET
8	1	DRIVER SIDE CENTER SUPPORT BRACKET	TORQUE WRENCH
9	1	PASSENGER SIDE CENTER MOUNT BRACKET	
10	12	M8 HEX HEAD BOLT	
11	12	M8 SPLIT LOCK WASHER	
12	6	M10 HEX NUT	
13	2	M10 HEX HEAD BOLT	
14	6	M10 SPLIT LOCK WASHER	
15	8	M10 FLAT WASHER	
16	12	M8 FLAT WASHER	
17	2	M10 U BOLT	

ANTI-SEIZE LUBRICANT MUST BE USED ON ALL STAINLESS STEEL FASTENERS TO PREVENT THREAD DAMAGE AND GALLING

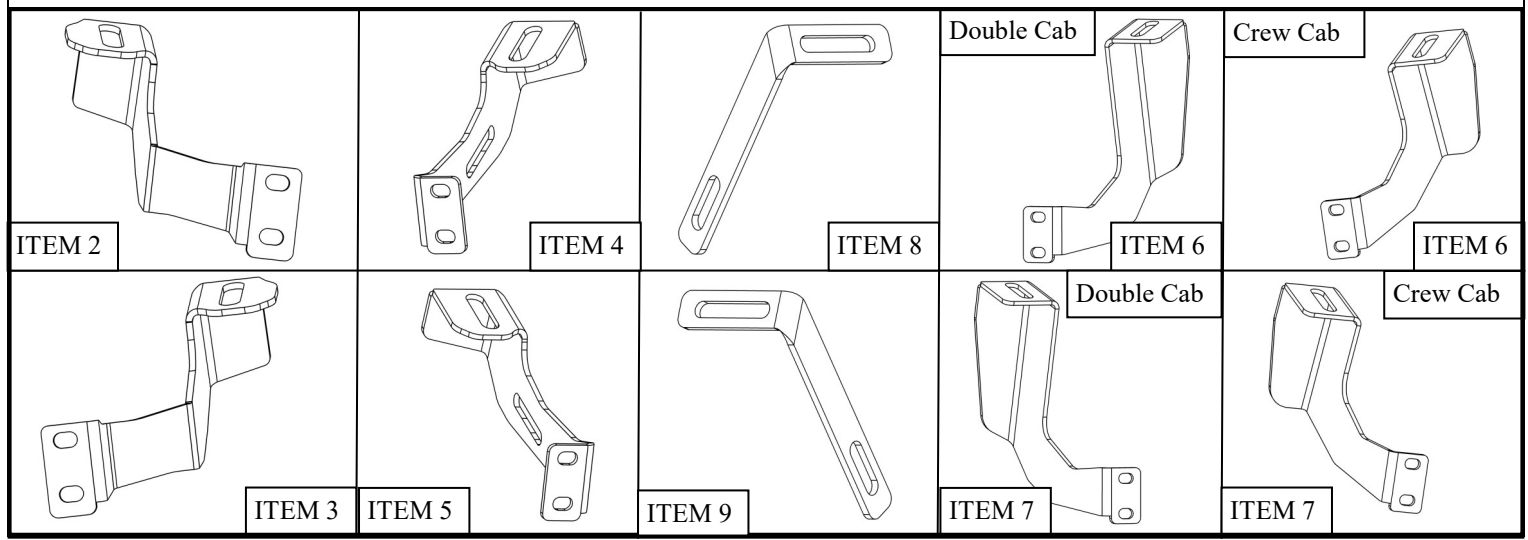

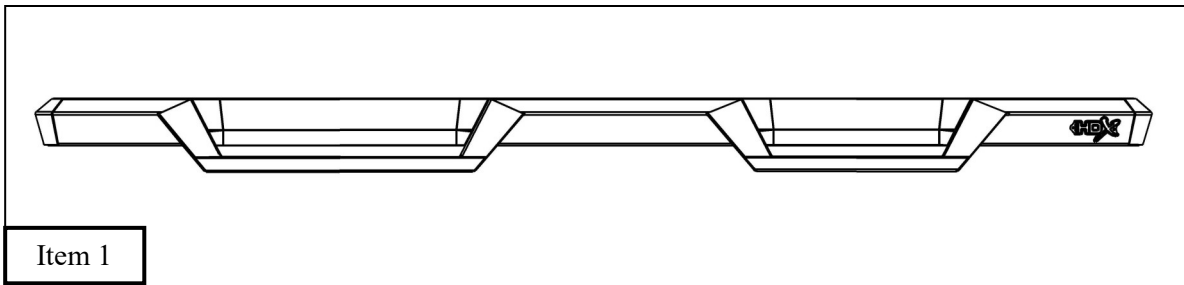

Item 1

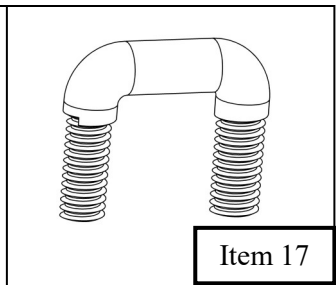

Item 17

PROCEDURE

1. Remove contents from box, verify if all parts listed are present and free from damage. Carefully read and understand all instructions before attempting installation.
Failure to identify damage before installation could lead to a rejection of any claim.

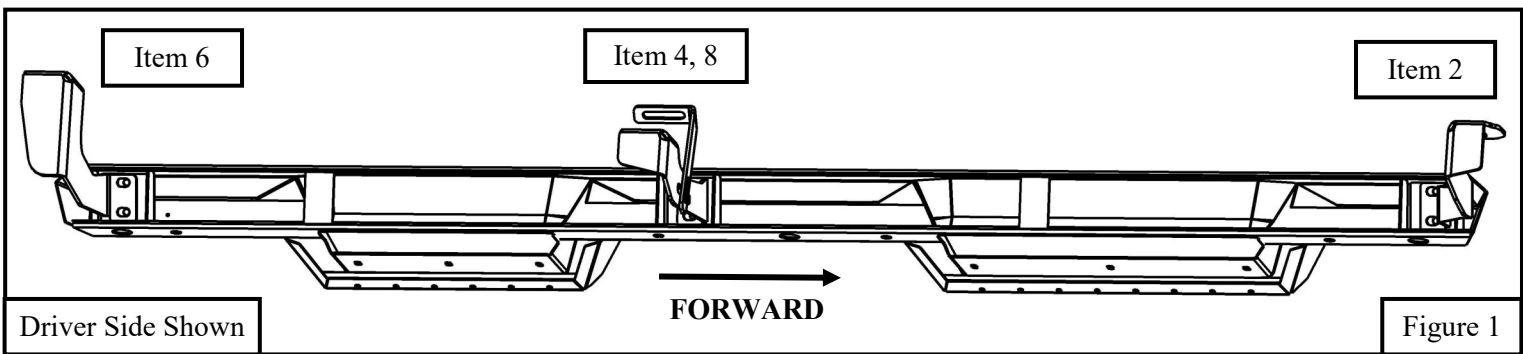

2. Start at the front driver side of the vehicle and remove the factory bolt from the puck mount on the frame. Grab the front driver side mount bracket and install loosely with previously removed factory bolt.. See **Figure 2**.
3. Move to the center mount position and insert the supplied U bolt. See **Figure 3**.

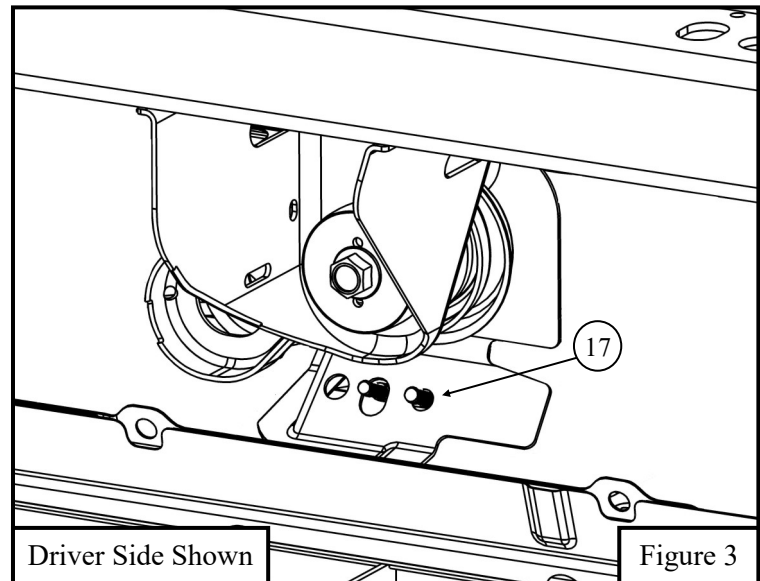
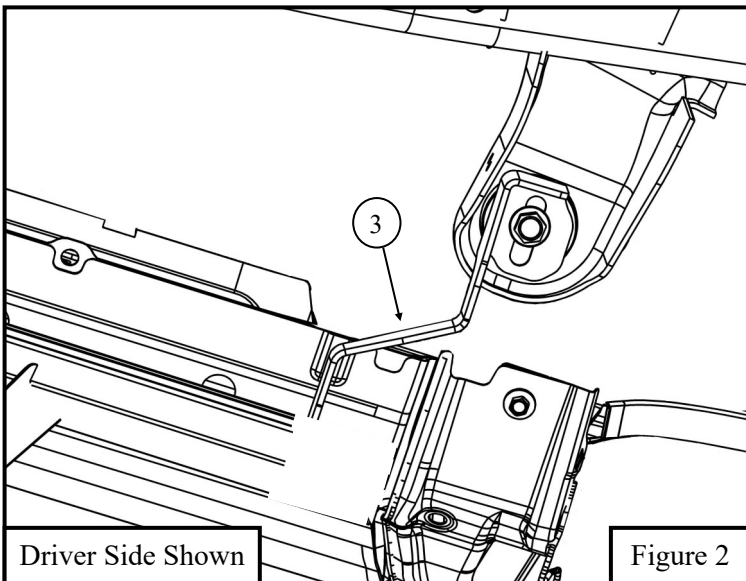

4. Move on to the center body puck mount on the driver side. Install the center bracket with the factory bolt loosely. See **Figure 4**.
5. Loosely install the center mount bracket with the support bracket using the supplied M10 hardware See **Figure 5**.

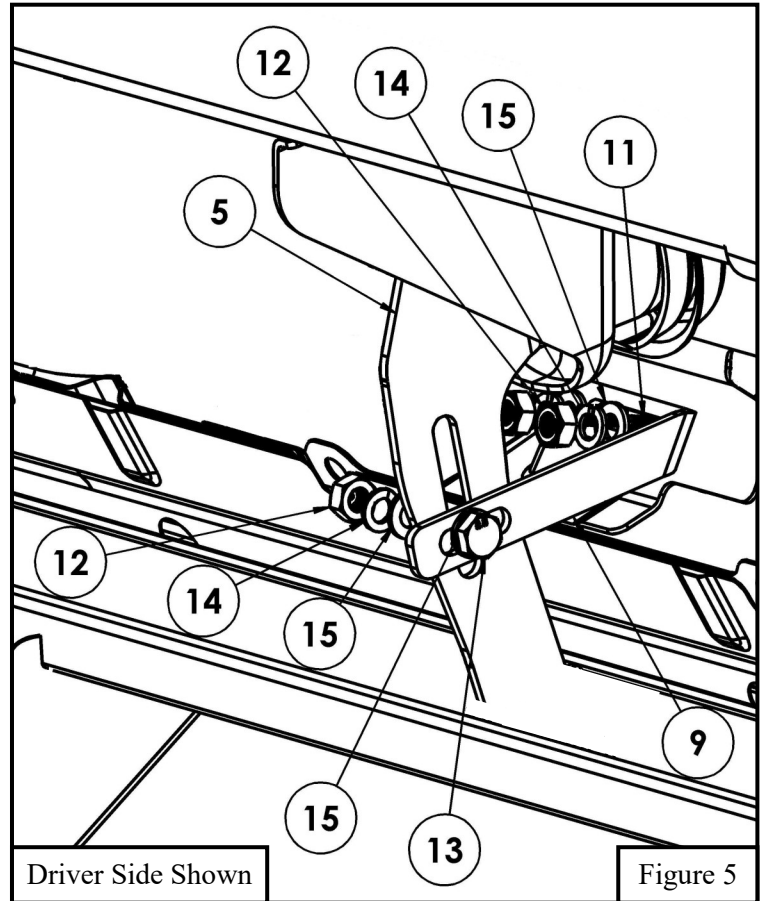
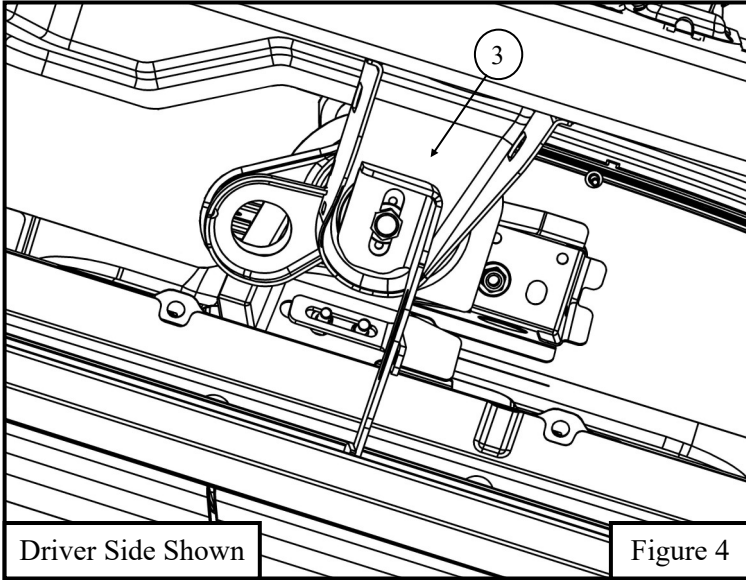

6. Move on the rear body puck mount and install the rear mount bracket with the factory bolt loosely. Crew Cab shown. See **Figure 6**. Double Cab installation similar.

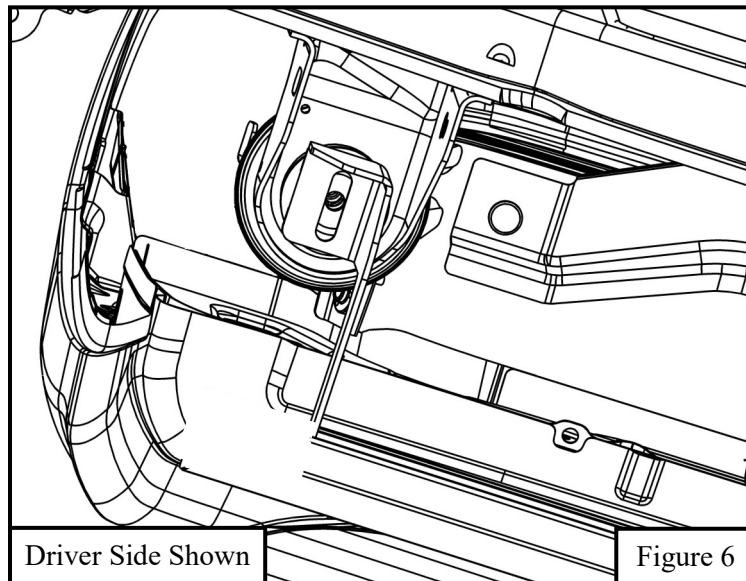

7. Before installing board to the previously installed brackets tilt backwards for easy entry into mount location. See **Figure 7**
8. Loosely Install step bars respectively to either side using the M8 hardware provided with the step bars. See **Figure 8**
9. Repeat Steps 1-8 for the passenger side.
10. Align and adjust the step bars as needed and fully tighten all hardware. Torque all M8 fasteners to 15-18 ft-lbs and M10 fasteners to 30-32 ft-lbs.

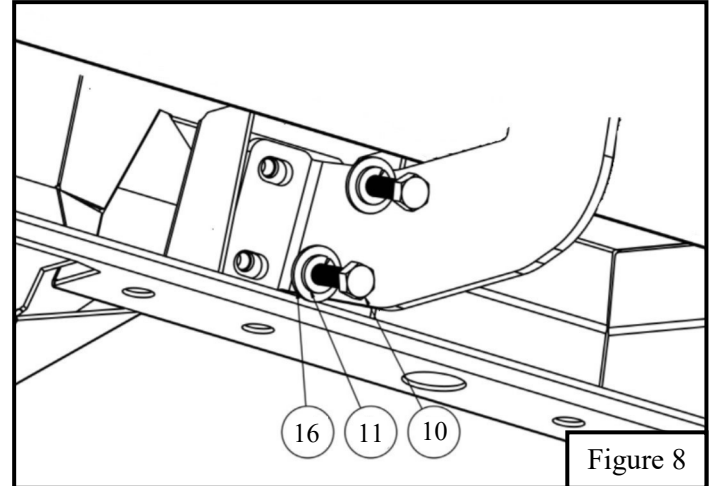
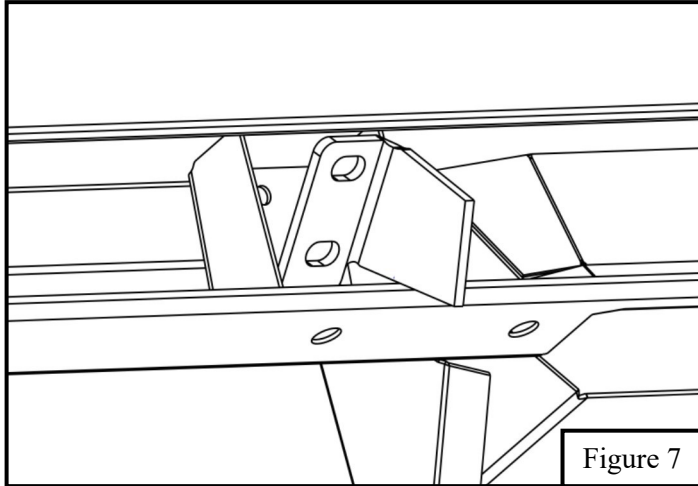

INSTALLATION COMPLETE



Care Instructions

- REGULAR WAXING IS RECOMMENDED. DO NOT USE ANY TYPE OF POLISH OR WAX THAT MAY CONTAIN ABRASIVES.
- STAINLESS STEEL PRODUCTS CAN BE CLEANED WITH MILD SOAP AND WATER. STAINLESS STEEL POLISH SHOULD BE USED TO POLISH SMALL SCRATCHES.
- GLOSS BLACK FINISHES SHOULD BE CLEANED WITH MILD SOAP AND WATER.

WESTiN