



INSTALLATION INSTRUCTIONS

SPORTSMAN WINCH MOUNT GRILLE GUARD

APPLICATION:

2016-2017 Toyota Tacoma

PART NUMBER:

40-93885, 45-93880, 46-23885

AUTOMOTIVE PRODUCTS,

ITEM	QUANTITY	DESCRIPTION	TOOLS NEEDED
1	1	WINCH TRAY	15MM SOCKET
2,3	2	LOWER MOUNT BRACKETS, (2) DRIVER AND (3) PASSENGER	18MM SOCKET
4,5	2	FRAME REINFORCED MOUNT BRACKETS, (4) DRIVER AND (5) PASSENGER	15MM WRENCH
6,7	2	UPPER SUPPORT STRAP, (6) DRIVER AND (7) PASSENGER	18MM WRENCH
8	8	M10 HEX HEAD CAP SCREW (YELLOW ZINC)	UTILITY KNIFE
9	8	M10 SPLIT LOCK WASHER (YELLOW ZINC)	8MM ALLEN
10	8	SMALL M10 FLAT WASHER (YELLOW ZINC)	6MM ALLEN
11	8	LARGE M10 FLAT WASHER (YELLOW ZINC)	SCREWDRIVER
12	8	M10 HEX NUT (YELLOW ZINC)	RATCHET
13	2	LONG M12 HEX HEAD CAP SCREW (YELLOW ZINC)	TORQUE WRENCH
14	2	LARGE M12 FLAT WASHER (YELLOW ZINC)	
15	2	MEDIUM M12 HEX HEAD CAP SCREW (YELLOW ZINC)	
16	8	SMALL M12 FLAT WASHER (YELLOW ZINC)	
17	6	M12 SPLIT LOCK WASHER (YELLOW ZINC)	
18	4	M12 HEX NUT (YELLOW ZINC)	
19	2	SHORT M12 HEX HEAD CAP SCREW (YELLOW ZINC)	
20	6	M12 HEX SOCKET BUTTON HEAD SCREW (BLACK ZINC)	
21	12	M12 FLAT WASHER (BLACK ZINC)	
22	6	M12 SPLIT LOCK WASHER (BLACK ZINC)	
23	6	M12 HEX NUT (BLACK ZINC)	
24	1	GRILLE GUARD ASSEMBLY	
25	8	M10 HEX SOCKET BUTTON HEAD BOLT (RAW OR BLACK ZINC)	
26	8	M10 FLAT WASHER (RAW OR BLACK ZINC)	
27	8	M10 SERRATED FLANGE NUT (RAW OR BLACK ZINC)	

ANTI-SEIZE LUBRICANT MUST BE USED ON ALL STAINLESS STEEL FASTENERS TO PREVENT THREAD DAMAGE AND GALLING

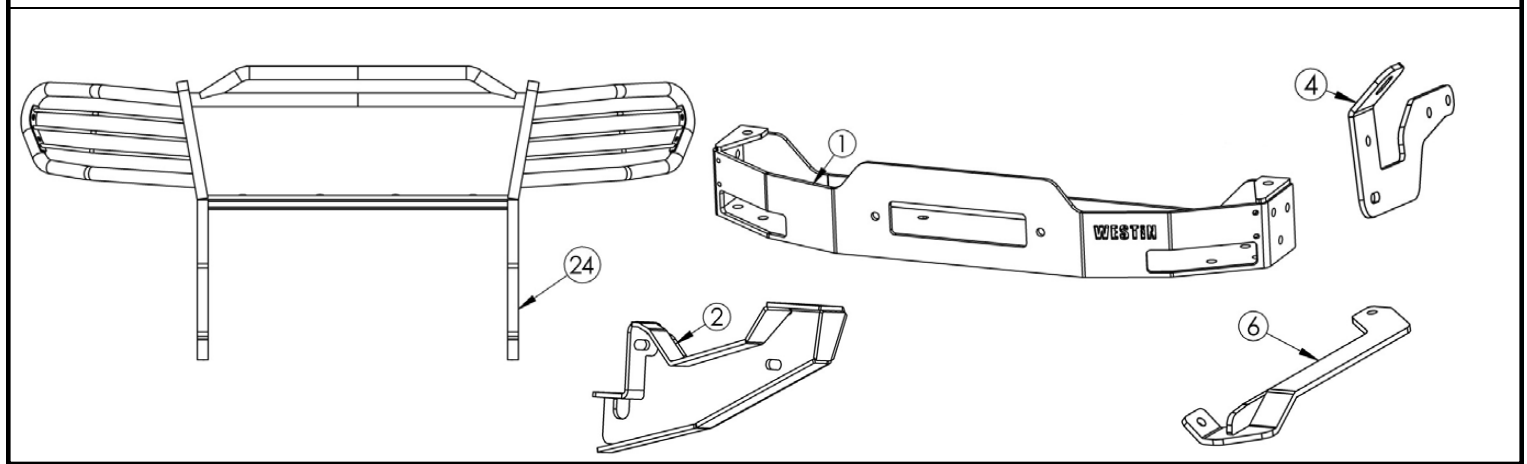

Thank you for choosing Westin products.

PROCEDURE

1. Remove contents from box, verify if all parts listed are present and free from damage.

Carefully read and understand all instructions before attempting installation.

Failure to identify damage before installation could lead to a rejection of any claim.

2. Remove the valance guard by removing screws from the front underside of the vehicle. See **Figure 1**.
3. Remove the license plate and remove the license plate holder by removing the two screws. See **Figure 2**.

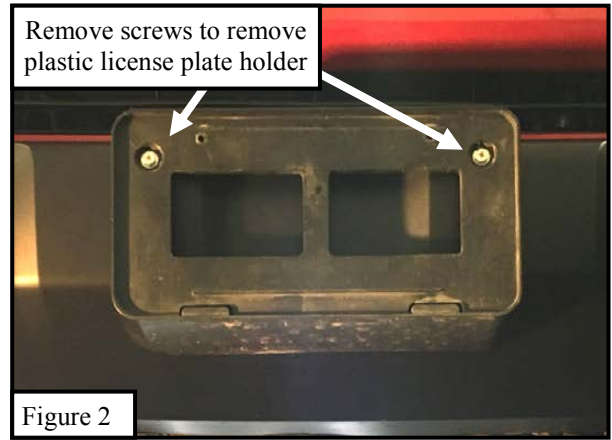
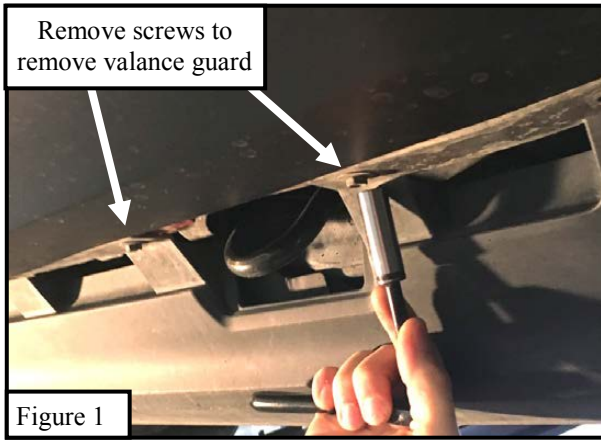

4. Under the hood of the vehicle remove screws and plastic push-pins to remove the grille. Once removed carefully pull off the grille guard. See **Figures 3 and 4**.

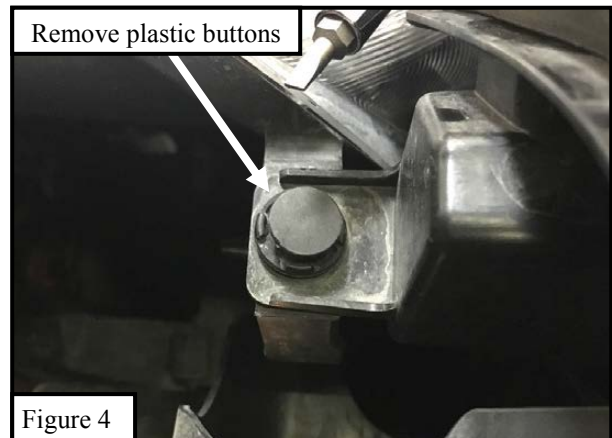

5. Remove plastic cover on both sides by removing the plastic push-pins. See **Figure 5**.



6. Locate (1) frame reinforced mount bracket and loosely secure onto frame channel using (4) M10 hex head cap screws, (4) M10 split lock washers, (4) small M10 flat washers, (4) large M10 flat washers and (4) M10 hex nuts. **NOTE:** Use the large M10 flat washers on the frame side. **NOTE:** The radiator may have to be loosened to allow proper clearance to install the bracket, once in place the radiator may be re-tightened. Repeat step for other side. **See Figures 6 and 7.**

NOTE: Install bracket from underneath the vehicle. As seen in Figure 7.



7. Remove the front plastic bumper insert. **Refer to Figure 5.** Locate the provided trim templates and align along the inside of the front plastic bumper insert. Follow instructions on the trim template and trim area as necessary. Reinstall front bumper. **See Figure 8.**
8. Insert (1) upper support strap through the recently trimmed slots on the bumper. Loosely attach the upper support straps onto the previously installed frame reinforced mount bracket using (1) medium M12 hex head cap screw, (2) small M12 flat washers, (1) M12 split lock washer and (1) M12 hex nut. Repeat for other side. **See Figures 9 and 10.**
9. Tighten M12 hardware of upper support strap to 50-55 ft-lbs.
10. Locate factory bolt on the frame and remove. Repeat for both sides. **See Figure 11.**

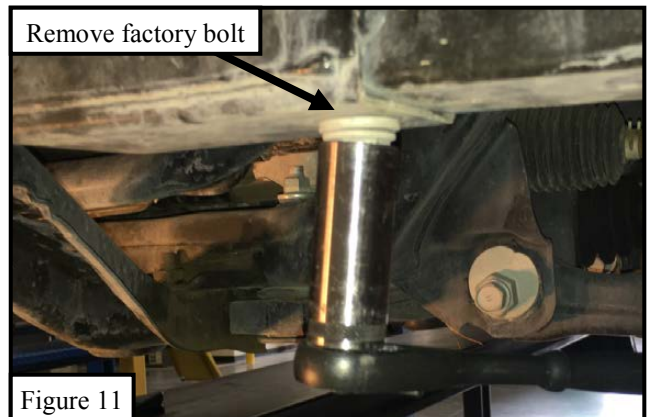
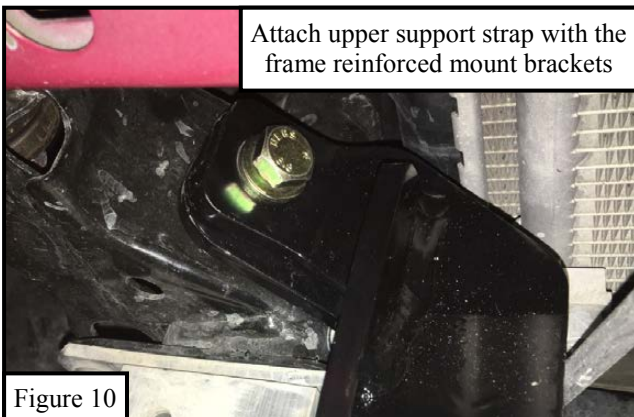
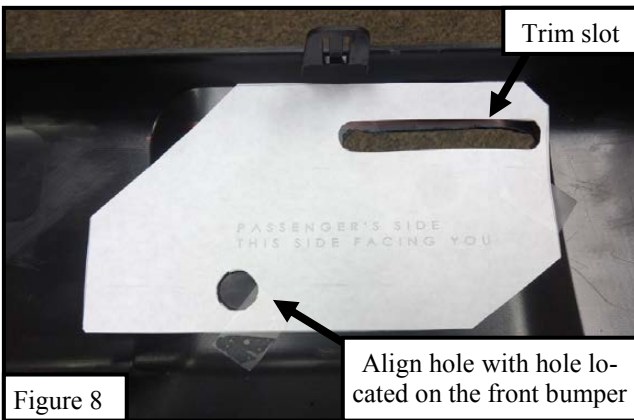

11. Locate (1) lower mount bracket and loosely install onto frame location where factory bolt was removed using (1) short M12 hex head cap screw, (1) M12 split lock washer and (1) small M12 flat washer. Loosely secure top mounting hole using (1) long M12 hex head cap screw, (1) small M12 flat washer, (1) large M12 flat washer, (1) M12 split lock washer and (1) M12 hex nut. **NOTE:** Large M12 flat washer is used on the frame side. **NOTE:** Remove bracket if present on mounting location. **See Figure 12.**
12. Reinstall the plastic covers and grille in the reverse order that they were taken off.
13. Loosely install the winch tray onto the previously installed lower mount brackets using (6) M12 hex socket button head screws, (12) M12 flat washers, (6) M12 split lock washers and (6) M12 hex nuts. **See Figure 13.**
14. With assistance loosely install the grille guard assembly onto the winch tray and the lower mount brackets using the provided M10 hardware (Item 25 - 27). **See Figure 14.**
15. Align and adjust the Winch Tray and Grille Guard Assembly as necessary. Tighten all remaining hardware: M10 to 30-35 ft-lbs and M12 to 50-55 ft-lbs.



Figure 12

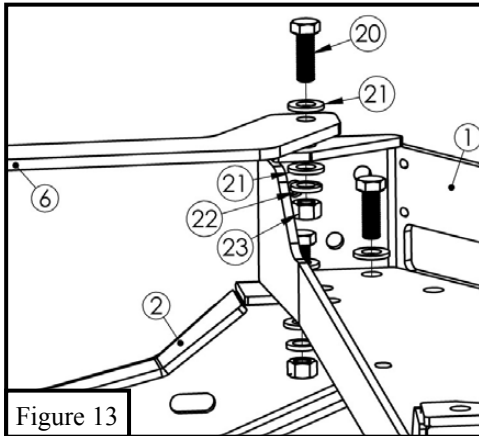

Figure 13

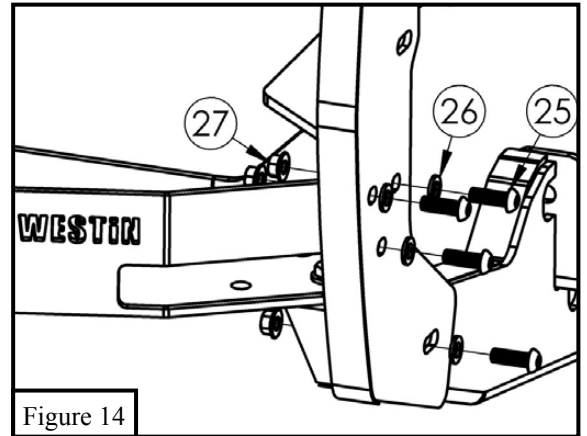

Figure 14



CARE INSTRUCTIONS

- REGULAR WAXING IS RECOMMENDED. DO NOT USE ANY TYPE OF POLISH OR WAX THAT MAY CONTAIN ABRASIVES.
- STAINLESS STEEL PRODUCTS CAN BE CLEANED WITH MILD SOAP AND WATER. STAINLESS STEEL POLISH SHOULD BE USED TO POLISH SMALL SCRATCHES.
- GLOSS BLACK FINISHES SHOULD BE CLEANED WITH MILD SOAP AND WATER.



Thank you for choosing Westin products.



SIGNATURE OF QUALITY

AUTOMOTIVE PRODUCTS, INC.



WARNING



Failure to follow these instructions could lead to death, personal injury, and / or property damage.

FASTENERS:

All Westin supplied fasteners must be utilized and installed in accordance with the installation instructions and apply torque to the specifications as defined. **DOUBLE CHECK ALL FASTENERS BEFORE INITIAL USE, AND PERIODICALLY IN THE FUTURE TO ENSURE PROPER FUNCTION AND SAFETY.**

DRILLING:

Most Westin products do not require drilling for installation. If drilling is defined as required, use caution when drilling a vehicle. **FAILURE TO REVIEW AN AREA TO BE DRILLED MAY RESULT IN PERSONAL INJURY AND/OR INJURY TO OTHERS AS WELL AS VEHICLE DAMAGE.**

EYE PROTECTION:

ALWAYS WEAR SAFETY GLASSES OR GOGGLES DURING THE INSTALLATION PROCESS TO AVOID PERSONAL INJURY.

MAXIMUM TOWING/CARRYING CAPACITY:

The Westin Receiver Hitches will have a visible tow rating label affixed directly on the product. User should never exceed the vehicle manufacturers maximum tow and weight rating regardless of the capacity of the hitch. **FAILURE TO FOLLOW THESE GUIDELINES WILL VOID THE WESTIN WARRANTY AND MAY RESULT IN PERSONAL INJURY AND/OR INJURY TO OTHERS AS WELL AS VEHICLE DAMAGE.**



Thank you for choosing Westin products.