

INSTALLATION INSTRUCTIONS

OIL PAN SKID PLATE

WESTiN®

APPLICATION:

2018-2019 Jeep Wrangler JL 2dr / Wrangler JL Unlimited 4dr
(Excl. 2018 JK)

PART NUMBER:

42-21095

CONTENT			
ITEM	QUANTITY	DESCRIPTION	TOOLS NEEDED
1	1	SKID PLATE	13MM SOCKET
2	1	MOUNTING BRACKET	13MM WRENCH
3	2	M8 ROUND HEAD SQUARE NECK BOLT	16MM WRENCH
4	3	M8 HEX HEAD BOLT	RATCHET
5	3	SMALL M8 FLAT WASHER	TORQUE WRENCH
6	3	LARGE M8 FLAT WASHER	
7	6	M8 SPLIT LOCK WASHER	
8	3	M8 HEX NUT	
9	1	M10 HEX HEAD BOLT	
10	1	M10 FLAT WASHER	
11	1	M10 SPLIT LOCK WASHER	
12	2	M8 PLASTIC RETAINER SQUARE	

ANTI-SEIZE LUBRICANT MUST BE USED ON ALL STAINLESS STEEL FASTENERS TO PREVENT THREAD DAMAGE AND GALLING

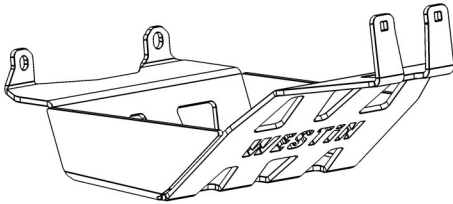

ITEM 1

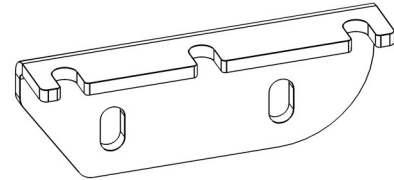

ITEM 2

PROCEDURE

1. Remove contents from box, verify if all parts listed are present and free from damage.
Carefully read and understand all instructions before attempting installation.
Failure to identify damage before installation could lead to a rejection of any claim.

WESTiN

- Remove the three M8 hex bolts on the front of the engine and attach the Mounting Bracket (2) to the motor in front of the oil pan using the supplied M8 Hex Bolt (4), M8 Split Lock Washer (7) and Small M8 Flat Washer (5). See **Figure 1**. Tighten M8 Hardware at this time to 18 ft-lbs.
- Remove the M10 bolt on the driver side of the engine and lift the Skid Plate (1) into position, and loosely attach the rear of the Skid Plate to the rear of the engine using the supplied M10 Hex Bolt (9), M10 Split Lock Washer (11), M10 Flat Washer (10) and Large M8 Flat Washer (6), M8 Split Lock Washer (7), and M8 Hex Nut (8). See **Figure 2**.

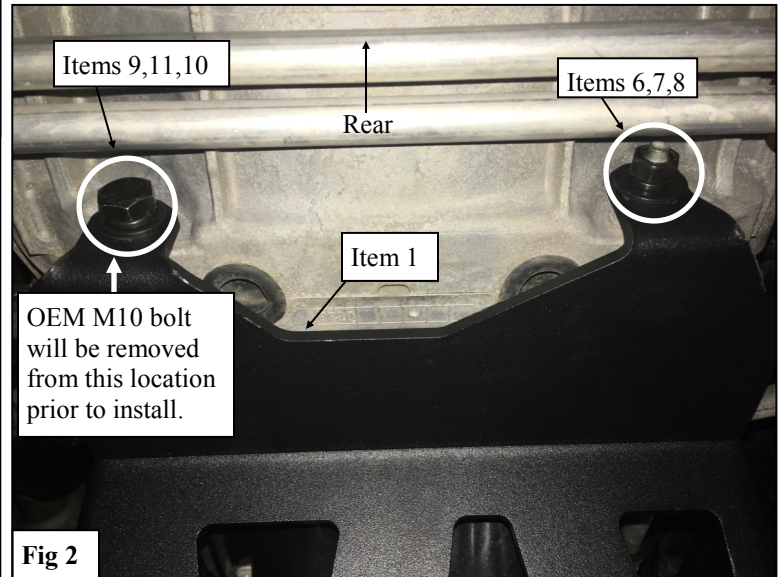
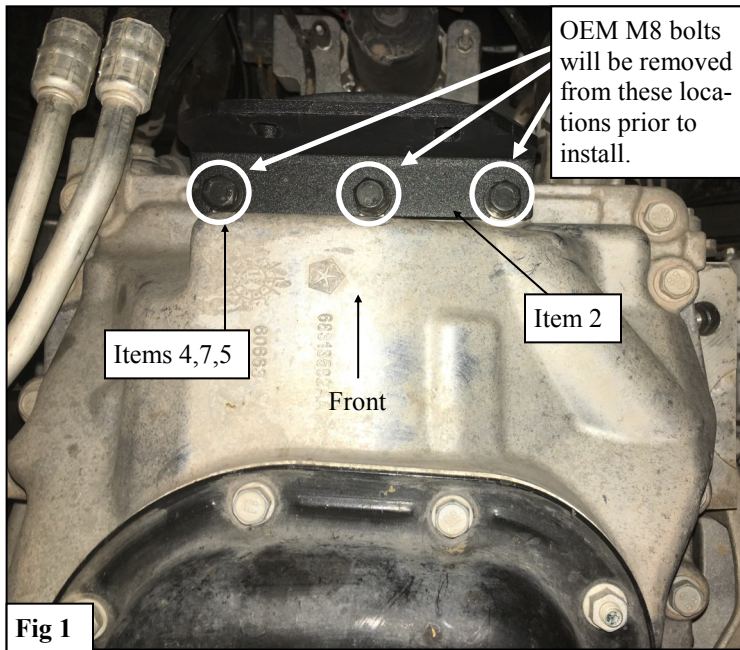

- Loosely attach the Skid Plate (1) to the Mounting Bracket (2) using the supplied M8 Hardware. See **Figure 3**. Adjust Mounting Bracket if necessary.
- Torque all hardware as specified: M8 to 18 ft-lbs, M10 to 38 ft-lbs.

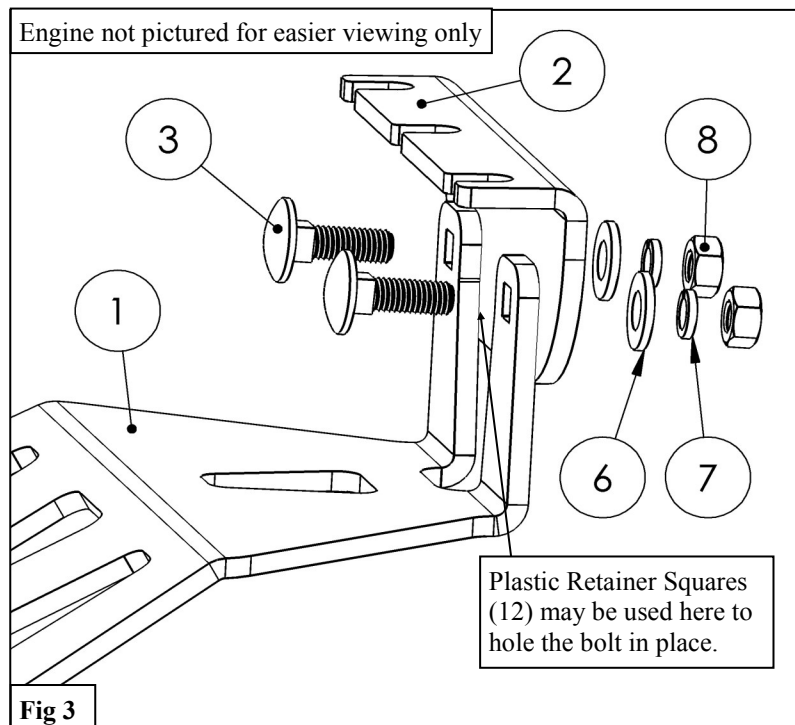

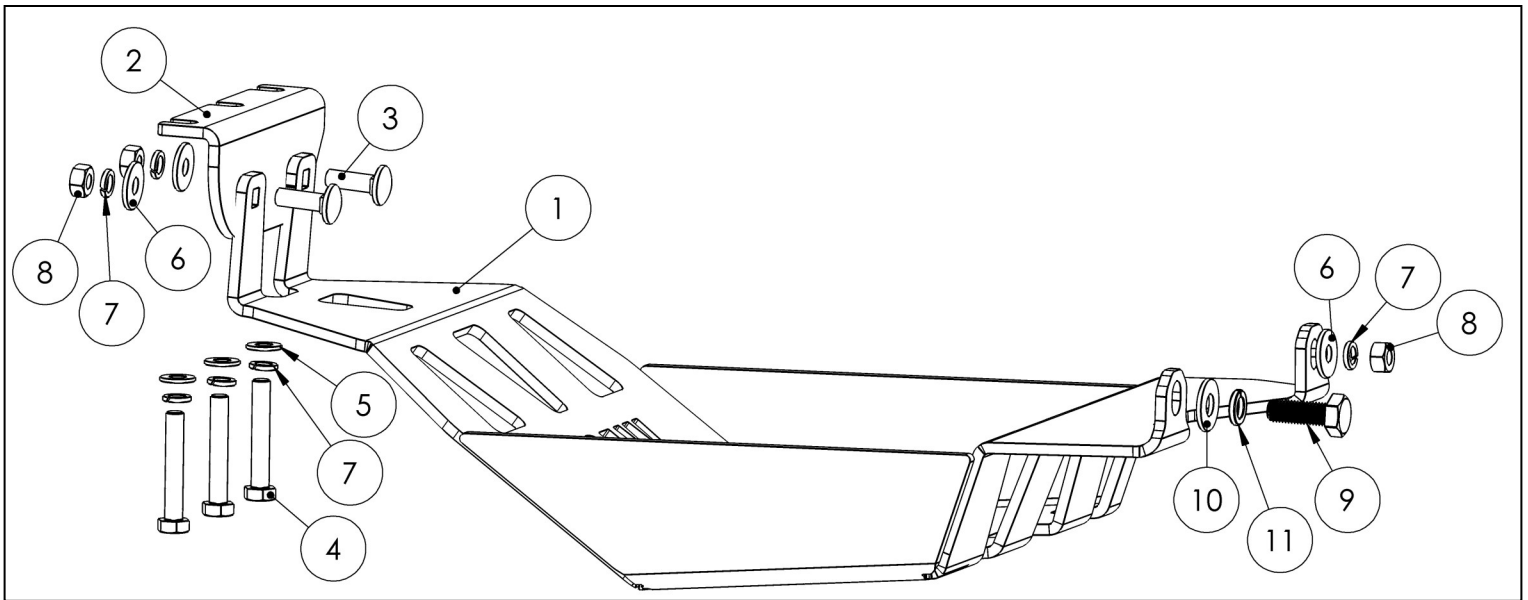

CARE INSTRUCTIONS

- REGULAR WAXING IS RECOMMENDED. DO NOT USE ANY TYPE OF POLISH OR WAX THAT MAY CONTAIN ABRASIVES.
- STAINLESS STEEL PRODUCTS CAN BE CLEANED WITH MILD SOAP AND WATER. STAINLESS STEEL POLISH SHOULD BE USED TO POLISH SMALL SCRATCHES.
- GLOSS BLACK FINISHES SHOULD BE CLEANED WITH MILD SOAP AND WATER

WESTIN



WARNING



Failure to follow these instructions could lead to death, personal injury, and / or property damage.

Failure to follow these instructions could lead to death, personal injury, and / or property damage.

FASTENERS:

All Westin supplied fasteners must be utilized and installed in accordance with the installation instructions and apply torque to the specifications as defined. **DOUBLE CHECK ALL FASTENERS BEFORE INITIAL USE, AND PERIODICALLY IN THE FUTURE TO ENSURE PROPER FUNCTION AND SAFETY.**

DRILLING:

Most Westin products do not require drilling for installation. If drilling is defined as required, use caution when drilling a vehicle. **FAILURE TO REVIEW AN AREA TO BE DRILLED MAY RESULT IN PERSONAL INJURY AND/OR INJURY TO OTHERS AS WELL AS VEHICLE DAMAGE.**

EYE PROTECTION:

ALWAYS WEAR SAFETY GLASSES OR GOGGLES DURING THE INSTALLATION PROCESS TO AVOID PERSONAL INJURY.

MAXIMUM TOWING/CARRYING CAPACITY: (if applicable)

The Westin Receiver Hitches will have a visible tow rating label affixed directly on the product. User should never exceed the vehicle manufacturers maximum tow and weight rating regardless of the capacity of the hitch. **FAILURE TO FOLLOW THESE GUIDELINES WILL VOID THE WESTIN WARRANTY AND MAY RESULT IN PERSONAL INJURY AND/OR INJURY TO OTHERS AS WELL AS VEHICLE DAMAGE.**

FOR CALIFORNIA RESIDENTS ONLY-PROP 65 WARNING:

Some products may contain chemicals such as DEHP, which can cause cancer, birth defects or other reproductive harm.



Learn more about off-road skid plates we have.