



# INSTALLATION INSTRUCTIONS

HDX & SPORTSMAN GRILLE GUARD

APPLICATION:  
2019 Ford Ranger  
PART NUMBER:  
57-3985, 40-3985

CONTENT			
ITEM	QUANTITY	DESCRIPTION	TOOLS NEEDED
1	1	GRILLE GUARD	10MM SOCKET
2	1	LOWER DRIVER MOUNTING BRACKET	RATCHET
3	1	LOWER PASSENGER MOUNTING BRACKET	TORQUE WRENCH
4	1	TOP DRIVER MOUNTING BRACKET	ALLEN
5	1	TOP PASSENGER MOUNTING BRACKET	13MM SOCKET
6	1	M6 SERATED FLANGE HEX NUT (YELLOW ZINC)*	17MM SOCKET
7	2	M8 HEX HEAD BOLT (YELLOW ZINC)	19MM SOCKET
8	2	M8 SPLIT LOCK WASHER (YELLOW ZINC)	
9	4	M12 HEX HEAD CAP SCREW (YELLOW ZINC)	
10	4	M12 SPLIT LOCK WASHER (YELLOW ZINC)	
11	4	M12 FLAT WASHER (YELLOW ZINC)*	
12	1	M6 BUTTON HEAD BOLT (BLACK)*	
13	1	M6 FLAT WASHER (BLACK)	
14	2	M10 BUTTON HEAD BOLT (BLACK)	
15	2	M10 SERRATED BELLVILLE WASHER (BLACK)	
16	2	M10 SERRATED FLANGE NUT (BLACK)	
17	4	M12 BUTTON HEAD BOLT (BLACK)	
18	4	M12 SERRATED BELLVILLE WASHER (BLACK)	
19	4	M12 SERRATED FLANGE NUT (BLACK)	
20	2	M12 NUT PLATE	
21	2	M8 FLAT WASHER (YELLOW ZINC)	
22	2	M6 LOCK WASHER (BLACK)*	

**ANTI-SEIZE LUBRICANT MUST BE USED ON ALL STAINLESS STEEL FASTENERS TO PREVENT THREAD DAMAGE AND GALLING**

\* These parts belong to the license plate relocation kit (sold separately). Part number **32-0055**

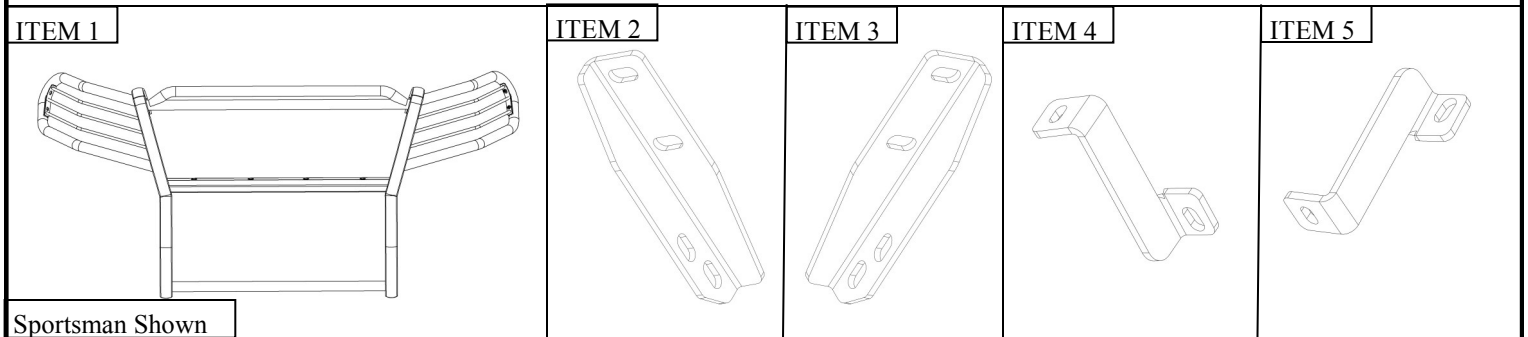

## PROCEDURE

1. Remove contents from box, verify if all parts listed are present and free from damage.  
Carefully read and understand all instructions before attempting installation.  
**Failure to identify damage before installation could lead to a rejection of any claim.**

2. Remove the five lower clips found under the front end of the bumper. See **Figure 1**
3. Carefully remove the front bumper cover by pulling from the bottom up. See **Figure 2**

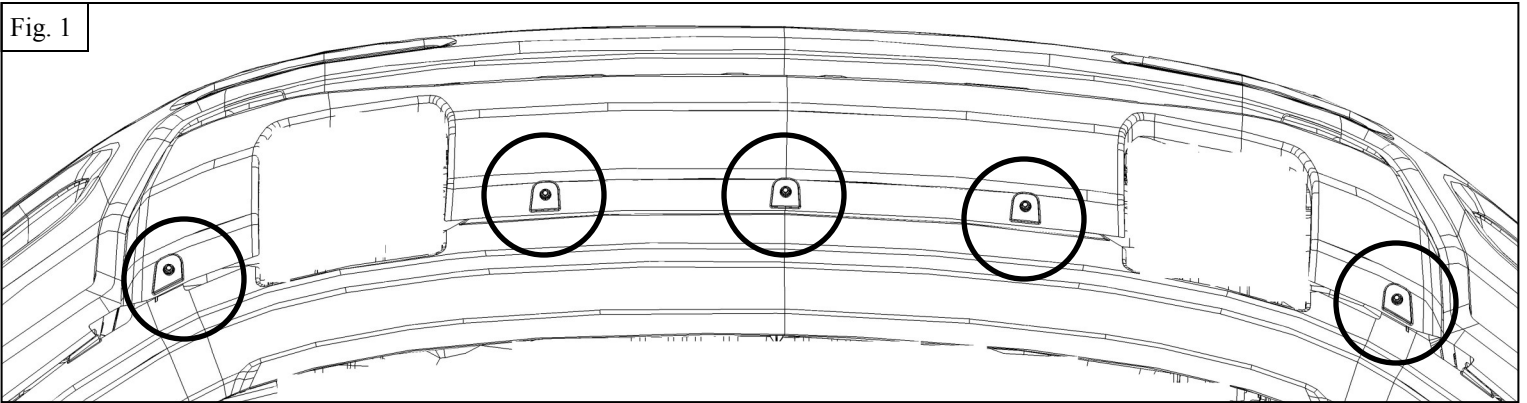

4. With the now exposed bumper plate, unbolt the bumper. See **Figure 3**
5. Unplug any connections to the bumper. See **Figure 4**
6. Remove the bumper.

Fig. 3



Fig. 4



7. If equipped, remove the factory tow hooks. *Note: Factory Tow hooks will not be reused.*
8. If tow hooks are equipped, remove tow hooks. Then loosely install the lower mounting brackets (2, 3) using the supplied M12 hardware.
- If tow hooks are not equipped, follow these instructions:
  - A. Using a cutting tool, cut out the tow hook cover panels. **See Figure 5**
  - B. Use the supplied nut plate (Item 20) and supplied M12 hardware to install the lower brackets. **See Figure 6.**

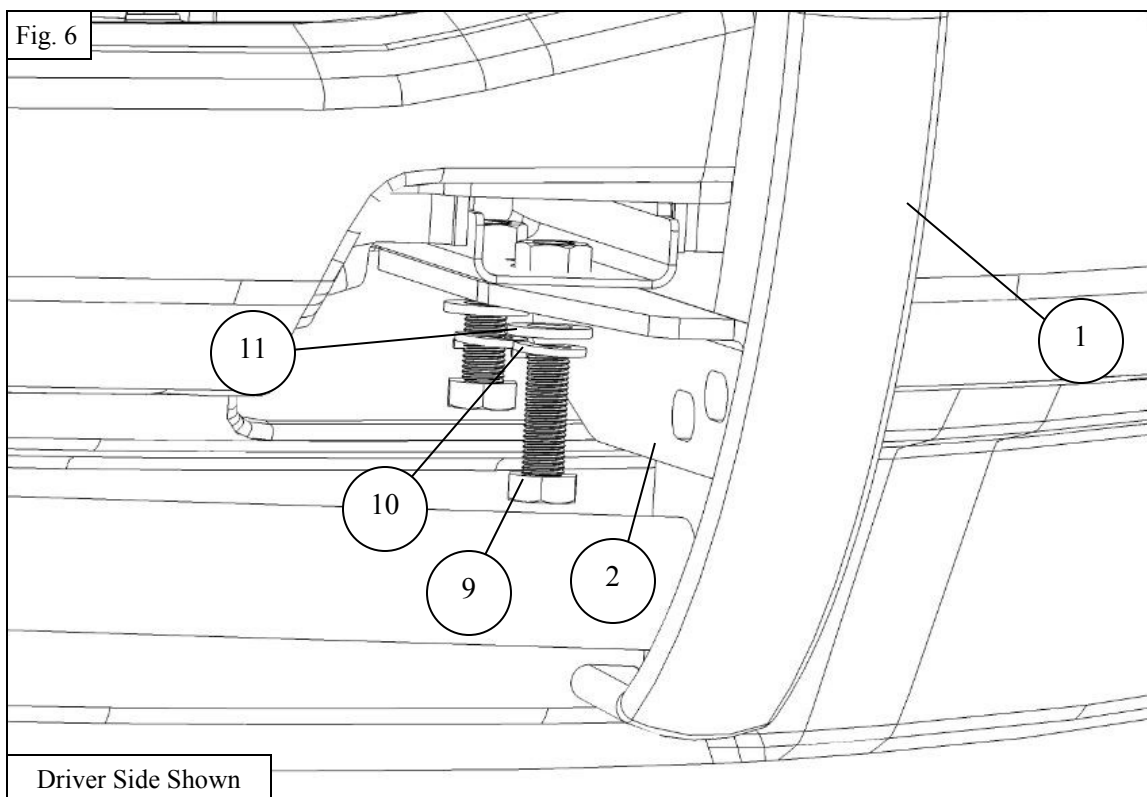
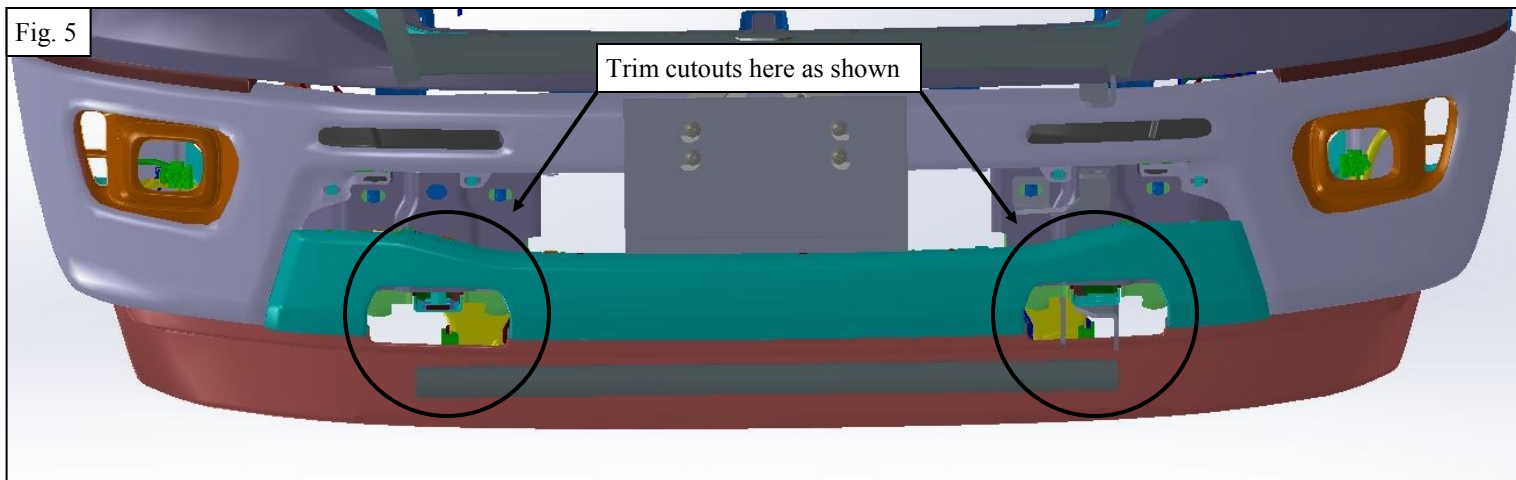

9. Loosely Install the upper mounting brackets onto the indicated locations on the bumper using the supplied M8 hardware.

**See Figure 7**

- A. Measure the distance between the upper brackets. Make sure it is 33 1/2 inches.
- B. Torque the M8 bolts to 18 ft lbs.
- C. Re-install the factory bumper.

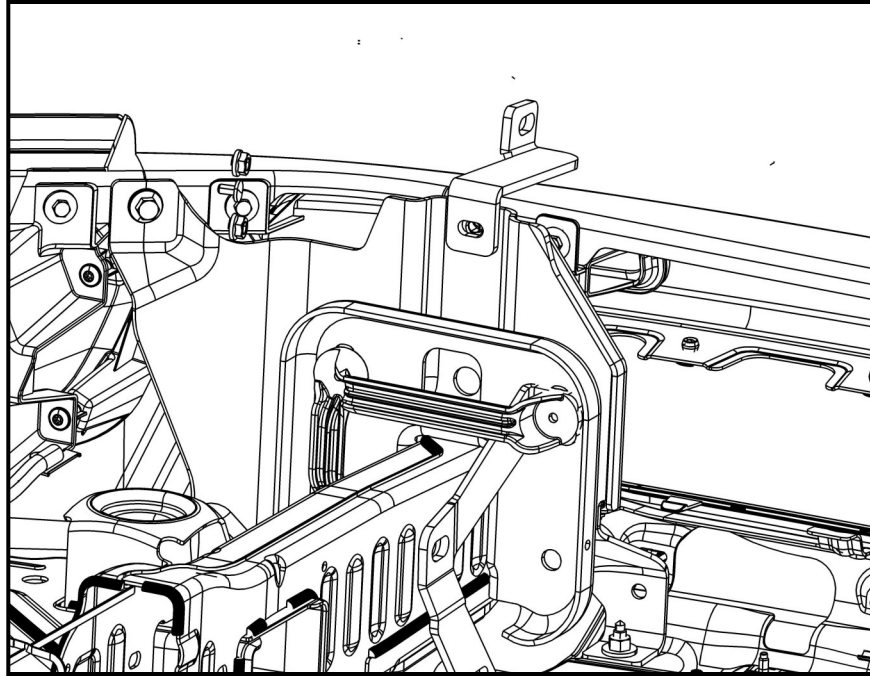
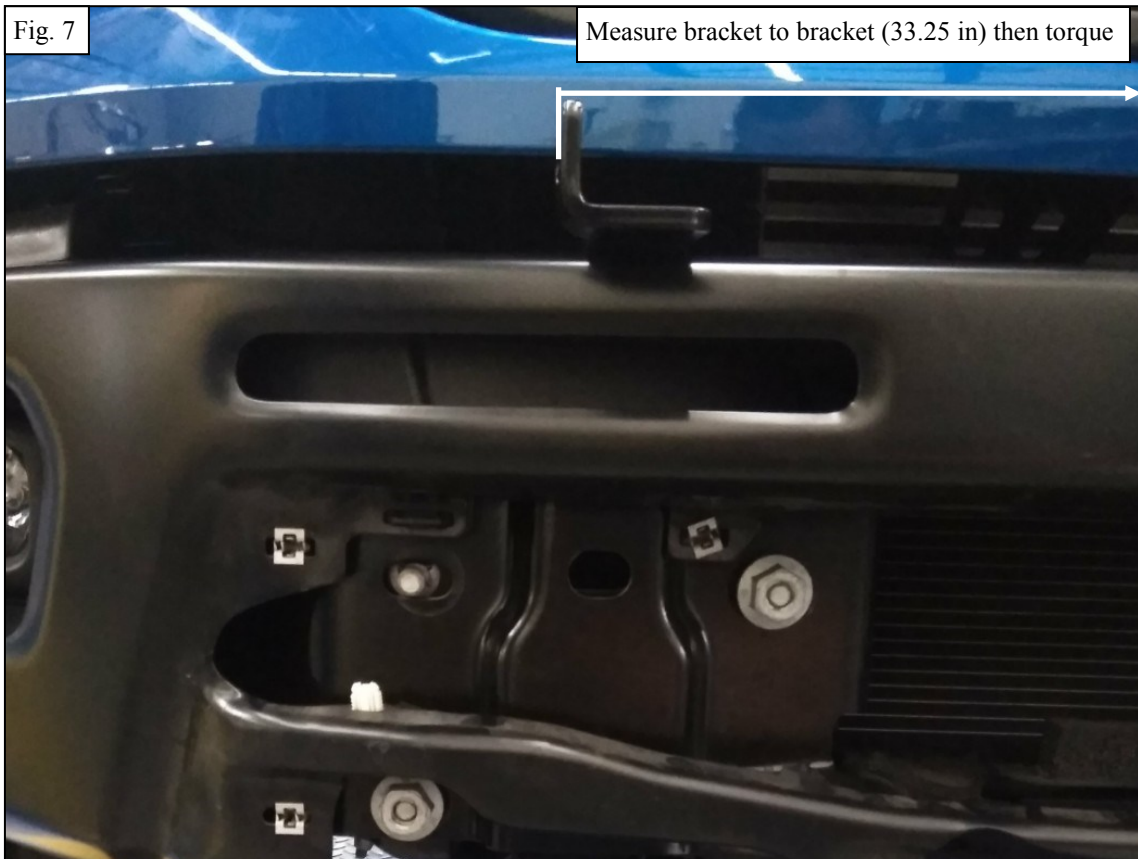
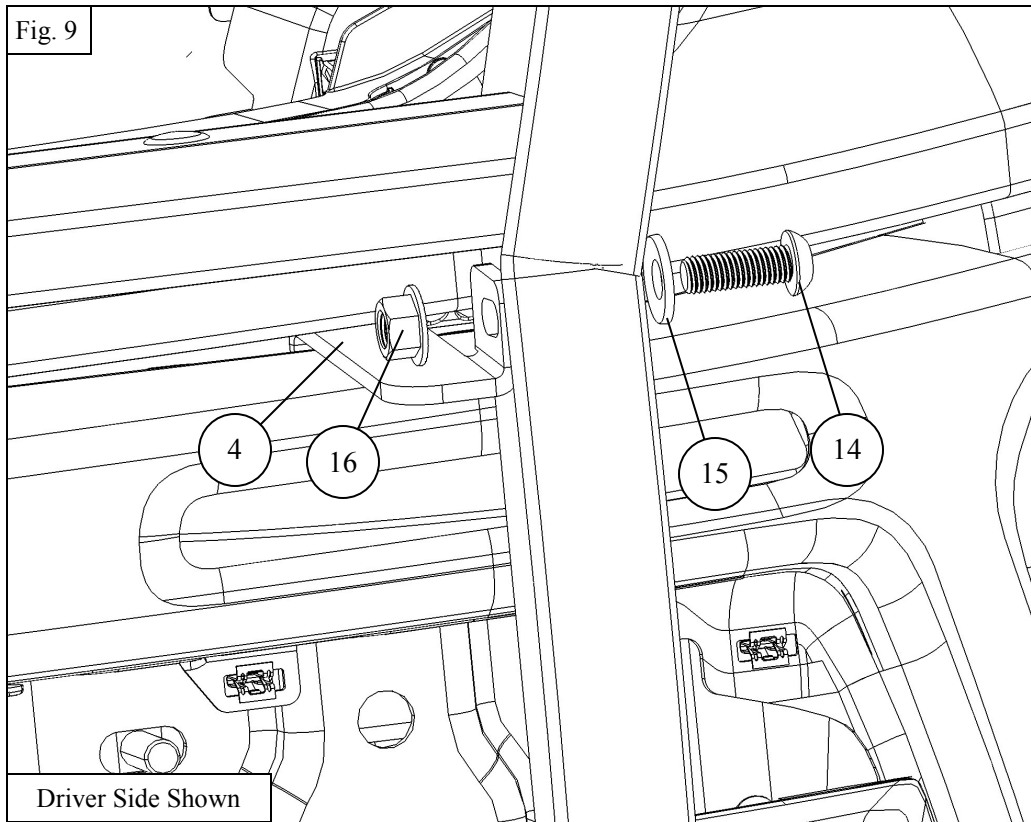
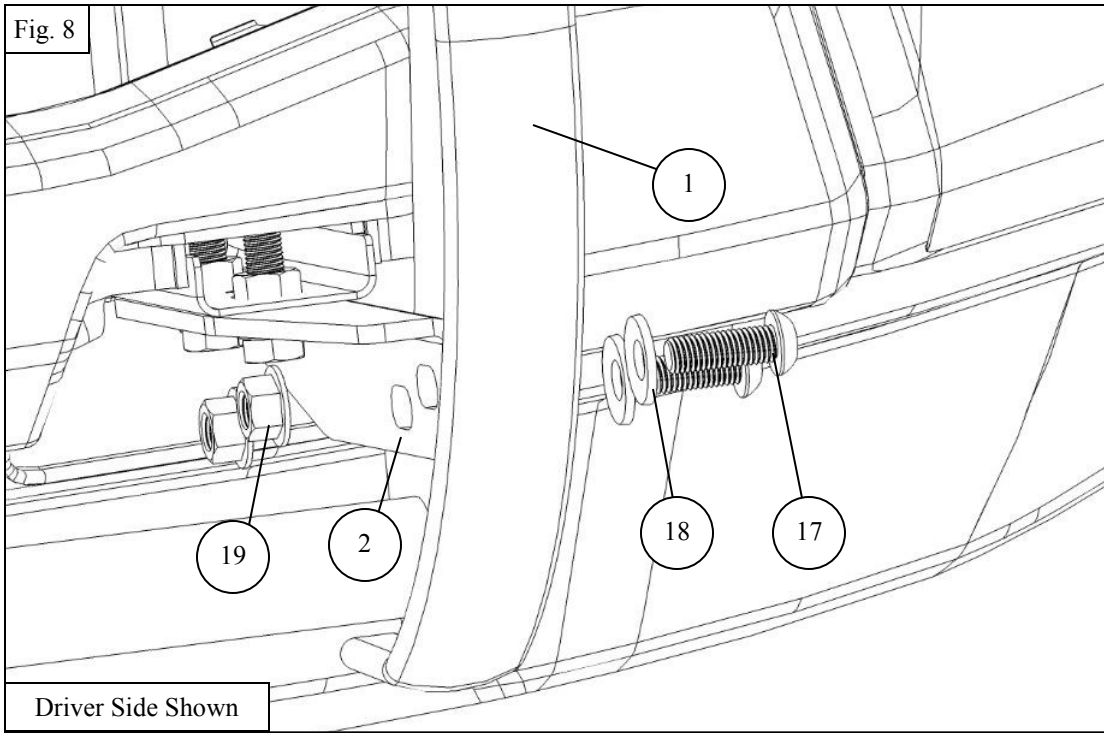

Fig. 7

Measure bracket to bracket (33.25 in) then torque



10. Loosely mount the grille guard assembly to the brackets on the vehicle using supplied M10 and M12 hardware. See Figure 8-9.



11. Adjust grille guard and torque down all bolts as specified: M6 to 7 ft lbs, M8 to 18 ft lbs, M10 to 35-40 ft lbs, M12 to 60 ft lbs.

12. Use M6 hardware to mount license plate with license plate relocater 32-0055, reference IS 75-0376.

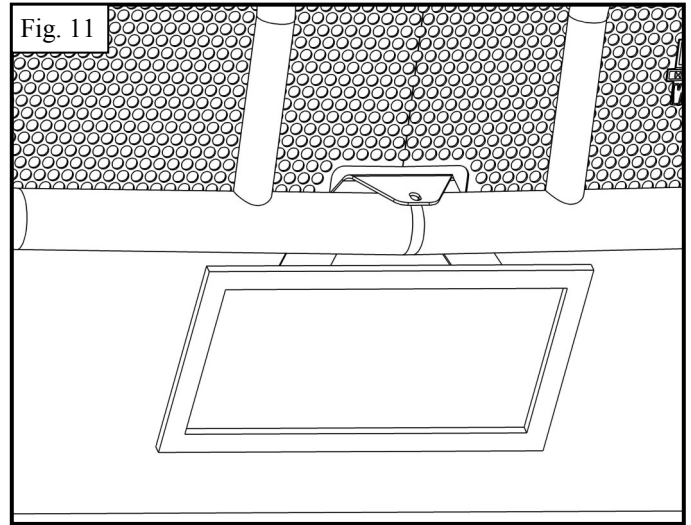
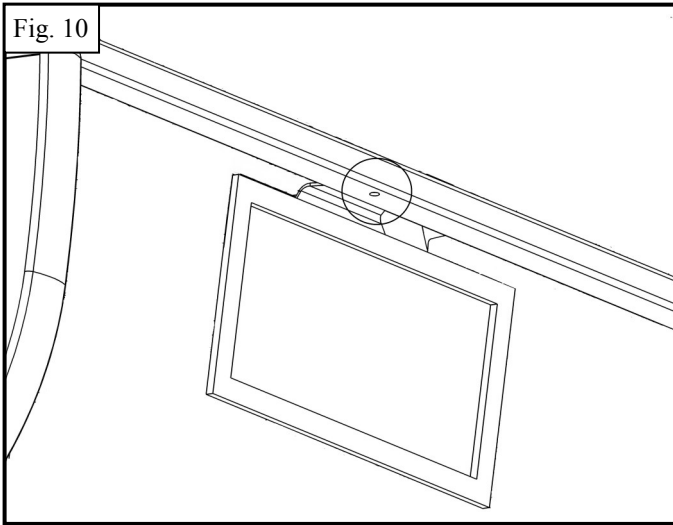

**INSTALLATION COMPLETE**



HDX Grille Guard Shown

#### Care Instructions

- REGULAR WAXING IS RECOMMENDED. DO NOT USE ANY TYPE OF POLISH OR WAX THAT MAY CONTAIN ABRASIVES.
- STAINLESS STEEL PRODUCTS CAN BE CLEANED WITH MILD SOAP AND WATER. STAINLESS STEEL POLISH SHOULD BE USED TO POLISH SMALL SCRATCHES.
- GLOSS BLACK FINISHES SHOULD BE CLEANED WITH MILD SOAP AND WATER.

**WESTIN**