



AUTOMOTIVE PRODUCTS, INC.

INSTRUCTIONS

APPLICATION: 2011 FORD EXPLORER
 APP PART # 40-3625, 45-3620
 SPORTSMAN GRILLE GUARD

ITEM	QUANTITY	DESCRIPTION	TOOLS NEEDED
1	1	GRILLE GUARD	18MM SOCKET
2,3	2	UPPER MOUNTING BRACKETS (2) DRIVERS SIDE, (3) PASSENGER SIDE	18MM WRENCH
4,5	2	LOWER MOUNTING BRACKETS (4) DRIVERS SIDE, (5) PASSENGER SIDE	16MM SOCKET
6	2	SPACER PLATES	13MM SOCKET
7	2	ADHESIVE BACKED PADS	10MM SOCKET
8	1	ADHESIVE BACKED FOAM	RATCHET
9	2	M12 BOLT PLATES	TORQUE WRENCH
10	2	M12 NUT PLATES	
11	2	M12 X 50MM HEX HEAD BOLTS	
12	6	M12 X 35MM HEX HEAD BOLTS	
13	10	M12 LOCK WASHERS	
14	16	M12 FLAT WASHERS	
15	8	M12 HEX NUTS	
16	2	M10 BUTTON HEAD BOLTS	
17	4	M10 FLAT WASHERS	
18	2	M10 NYLOCK NUTS	
19	2	M6 HEX HEAD BOLTS	
20	2	M6 FLAT WASHERS	
21	2	M6 LOCK WASHERS	
22	1	M5 HEX HEAD SCREW	
23	2	M5 FLAT WASHERS	
24	1	M5 NYLOCK NUT	

1. Remove all contents from box, verify parts listed are present and free from damage. Carefully read and understand all instructions before attempting installation.
2. Start installation under the driver side front of the vehicle, (Figure 1). Insert (1) M12 Nut Plate into the large oval opening in the bottom of the frame channel. Slide it forward in the frame with the flat side down-welded nut up, (Figure 2C). Line up the threaded hole in the Nut Plate with the factory hole at the front of the frame, (Figure 2A). Next, insert (1) M12 Bolt Plate into the large oval opening and center the threaded bolt in the oval hole, (Figure 2B).
3. Select the driver side Frame Mounting Bracket. Hold the Mounting Bracket up in position against the bottom of the frame and over the threaded bolt on the Bolt Plate, (Figure 3A). Secure the Bracket to the Bolt Plate with (1) M12 Flat Washer, (1) M12 Lock Washer and (1) M12 Hex Nut. Leave hardware loose at this time. Slide (1) Spacer Plate between the frame channel and the Bracket, (Figure 3A & 3B). Insert (1) M12 x 50mm Long Hex Bolt with (1) M12 Lock Washer and (1) M12 Flat Washer through the hole in the Bracket, Spacer Plate and into the Nut Plate, (Figure 4). Snug but do not tighten hardware at this time.



Thank You for choosing Westin products.

4. Move to the passenger side of the vehicle. Determine if the vehicle is equipped with the factory installed fresh air inlet in the plastic bumper cover. Vehicles without air inlet: Repeat Steps 2 & 3 for passenger side Frame Mounting Bracket installation, (Figures 5A, 5B & 5C). Vehicles equipped with air inlet, (Figure 6): Repeat Step 2 to install the M12 Bolt Plate and M12 Nut Plate. Hold the Frame Bracket in the approximate position over the Bolt and Nut Plates. Mark the outline of the Bracket onto the mounting tab on the plastic air inlet, (scoop), (Figure 7). Remove the inlet and place it on a clean, stable work surface. Use a hacksaw to cut the required material from the mounting area on the inlet. Check the fit often and trim material away as necessary. Do not cut off the mounting tab. Carefully pry off the metal clip and move it as indicated in Figure 7 or drill a 1/4" hole through the top and bottom of the scoop and replace the clip with the included (1) M5x 25mm Screw, (2) M5 Flat Washers and (1) M5 Nylon Lock Nut. Do not over-tighten 5mm hardware. IMPORTANT! Any cutting tool may break or shatter. Government regulations require safety glasses & equipment at all times when cutting. Install the Frame Bracket as described in Step 3. NOTE: Complete the Grille Guard installation before reinstalling the plastic air inlet scoop, (Step 15). NOTE: Before proceeding, it may be considerably easier to remove the plastic bumper cover to cut the slots for the Grille Guard. However, the bumper cover may be held in place with rivets making removal and reinstallation very difficult, (Figure 6). Determine if the bumper is held in place with rivets, (visible from the outside-below the fog lights), before attempting to remove the bumper cover.
5. Measure the width across the Grille Guard, (mounting tab to mounting tab-appx. 37" to 37-1/2"). Use a tape measure to locate the middle of the plastic bumper cover, (Figure 8). Mark the mid point on the back of the bumper. NOTE: You can also locate the mold mark on the back of the bumper to determine the mid point. Place a layer of masking tape on the back of the bumper cover in front of the Frame Mounting Brackets. On the driver side, draw a vertical line on the tape 18-1/2" out from the middle of the bumper cover to the driver side. Draw a second vertical line 19-1/2" out from the middle, (Figure 8).
6. Use the locations of the previously installed Frame Mounting Brackets to determine where to draw the top and bottom horizontal lines, (Figure 9). Carefully cut this area out of the bumper cover with a sharp knife or hacksaw, (Figure 10). IMPORTANT: Do not cut through the top or bottom edge of the bumper cover. Only remove enough material to clear the mounting tabs on the Grille Guard.
7. Repeat Steps 5 & 6 to cut out the passenger side of the bumper cover.
8. Reinstall the bumper cover if previously removed.
9. With assistance, position the Grille Guard onto the outside of the Mounting Brackets. Attach the Grille Guard to the Mounting Brackets with (6) M12 x 35mm Hex Bolts, (12) M12 Flat Washers and (6) M12 Nylon Lock Nuts, (Figure 11). Align, level and adjust the Grille Guard but do not completely tighten the hardware at this time.
10. Open the front hood. Cover the top of the grille and plastic cover, (driver and passenger sides), with removable tape, (masking tape preferred-tape not included), to avoid damage to finish during Top Bracket installation, (Figure 12). Select the driver side Top Bracket. Hold the Top Bracket in approximate position between the Grille Guard and the hex bolt on the top cover. Mark the location onto the tape on the plastic cover, (Figure 13). Repeat this Step for passenger side Top Bracket.
11. Remove the cover. Note the type and location of all factory hardware for reinstallation.
12. Next, place a 2" x 2" piece of the Thin Adhesive Backed Foam Tape on the underside of the Top Brackets anywhere it can come in contact with the top of the plastic grille, (Figure 14). Trim the Foam Tape as necessary.
13. Cut out the front edge of the cover and the front side of the indented pocket for the hex bolt, (Figures 15 & 16), to clear the Top Brackets. Once properly trimmed, place the cover in the original position.
14. Insert the driver side Top Bracket through the opening cut into the top cover and line up the mounting slot. Bolt the Top Bracket to the cover with the included (1) M6 Hex Bolt, (1) M6 Flat Washer and (1) M6 Lock Washer, (Figure 17). Line up the remaining, (forward), end of the Top Bracket with the hole in the upright on the Grille Guard. Bolt the Bracket to the inside of the upright with (1) M10 Button Head Bolt, (2) M10 Flat Washers and (1) M10 Nylon Lock Nut, (Figure 18). Repeat this Step for passenger side Top Bracket installation.
15. Align and adjust the Grille Guard properly and tighten all hardware. Torque all M12 fasteners to 50-55 ft lbs and M10 to 40-45 ft lbs. Remove protective masking tape from the top of the plastic grille, (Step 9).
16. Reinstall the air inlet, (scoop), removed in Step 4b. Trim scoop to clear Brackets as necessary.

CARE INSTRUCTIONS

- REGULAR WAXING IS RECOMMENDED. DO NOT USE ANY TYPE OF POLISH OR WAX THAT MAY CONTAIN ABRASIVES
- STAINLESS STEEL PRODUCTS CAN BE CLEANED WITH MILD SOAP AND WATER. STAINLESS STEEL POLISH SHOULD BE USED TO POLISH SMALL SCRATCHES.
- GLOSS BLACK FINISHES SHOULD BE CLEANED WITH MILD SOAP AND WATER



Thank You for choosing Westin products.

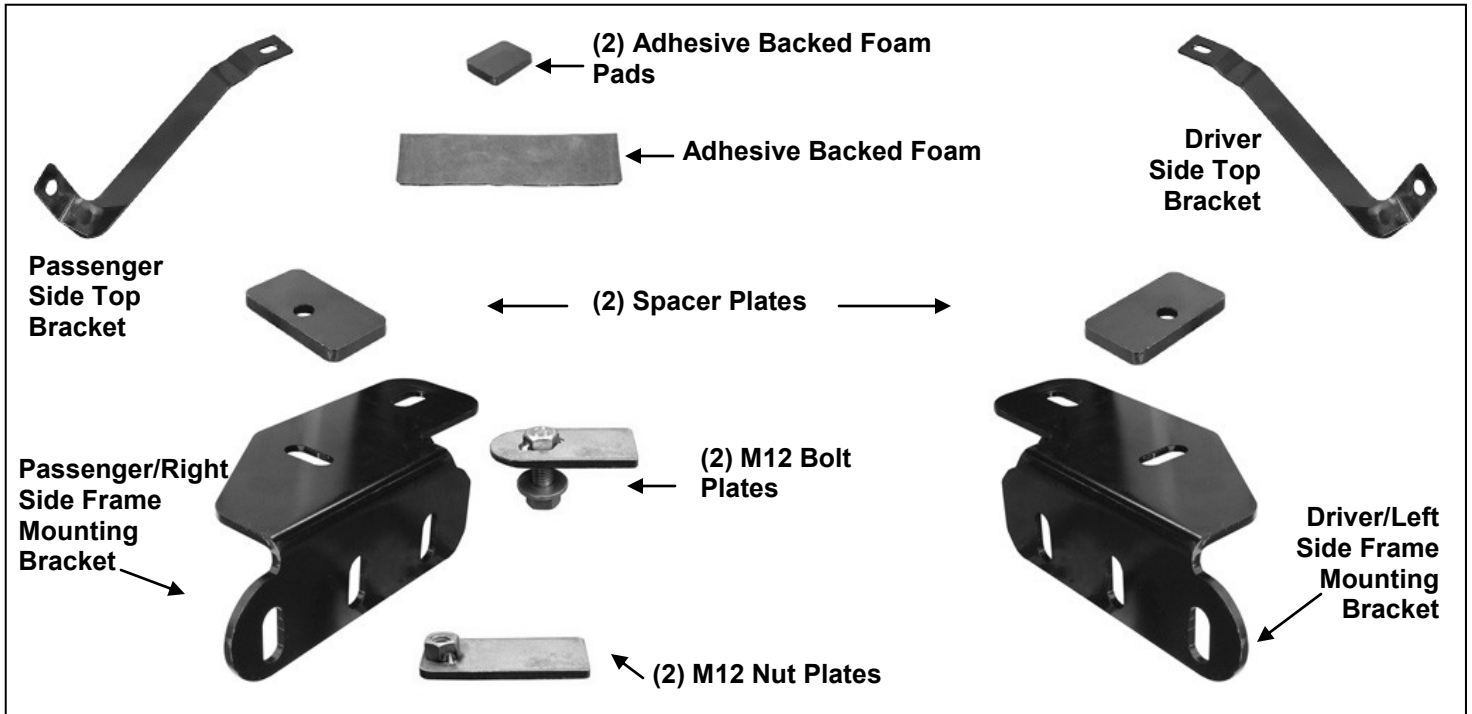

Thank You for choosing Westin products.

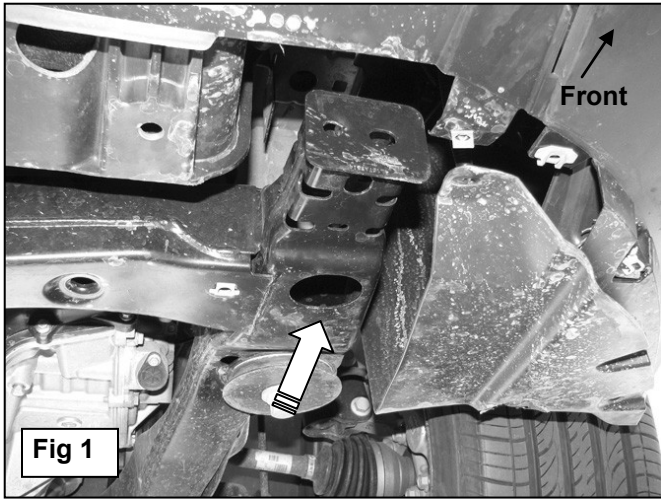
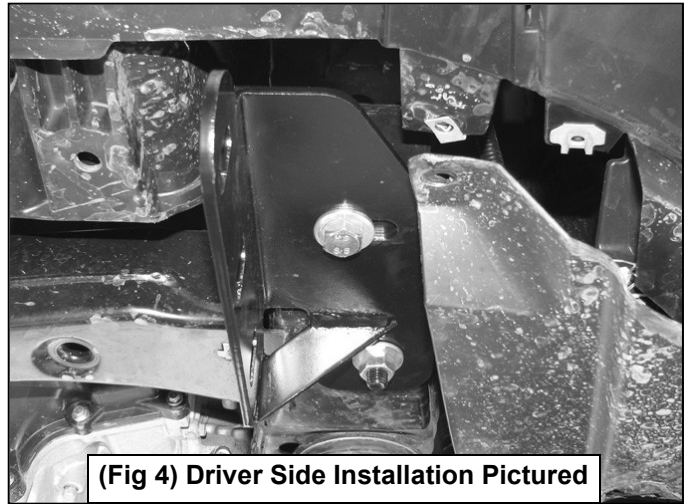

Fig 1



(Fig 4) Driver Side Installation Pictured



Fig 2B

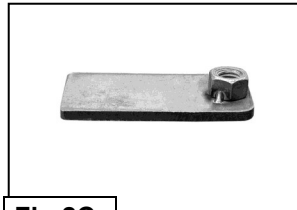

Fig 2C

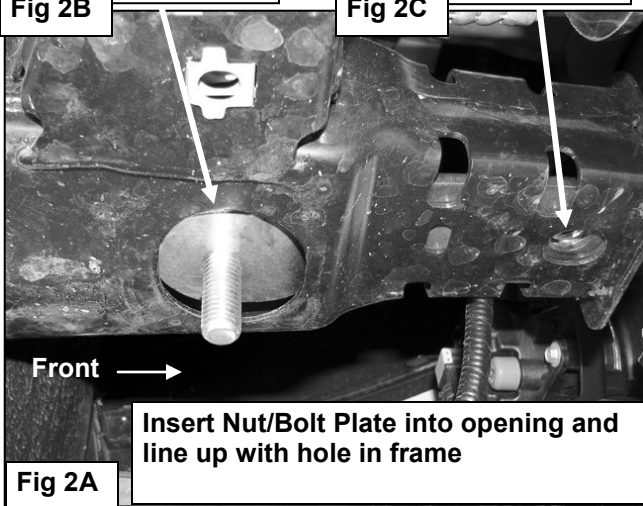

Fig 2A

Insert Nut/Bolt Plate into opening and line up with hole in frame

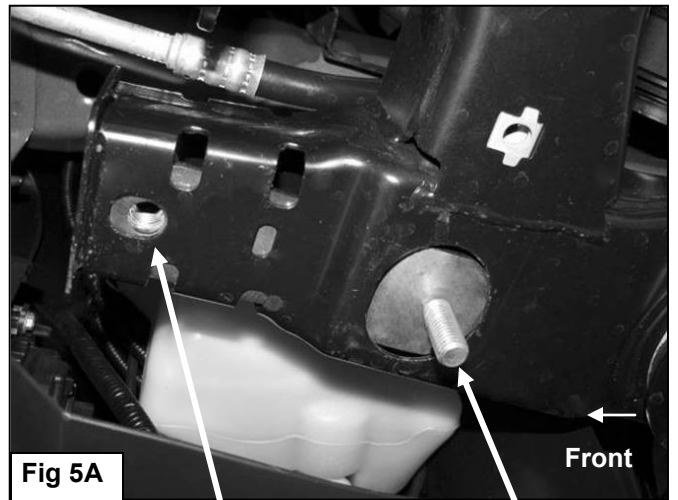

Fig 5A

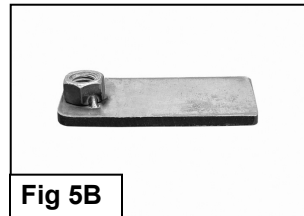

Fig 5B

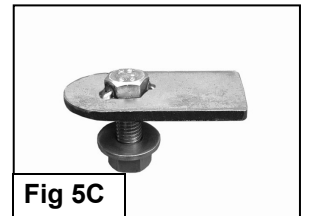

Fig 5C

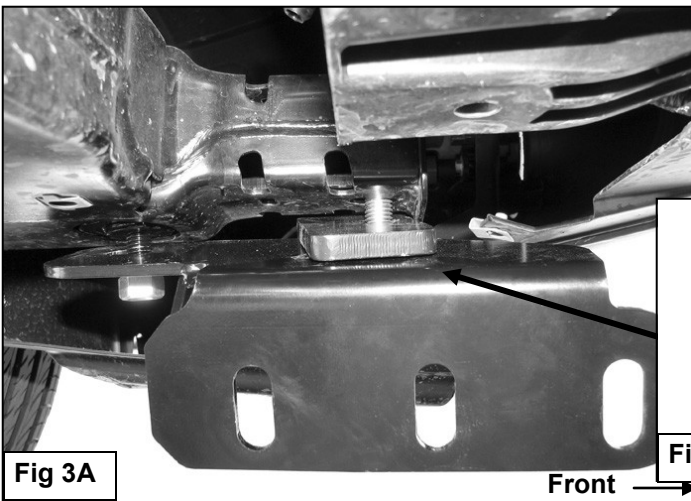

Fig 3A

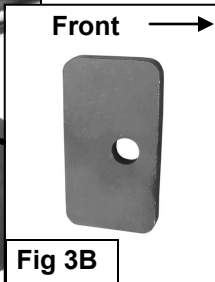

Fig 3B

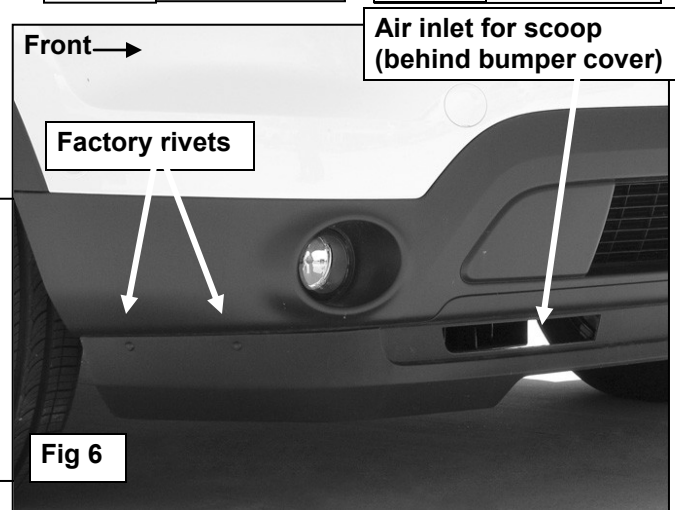
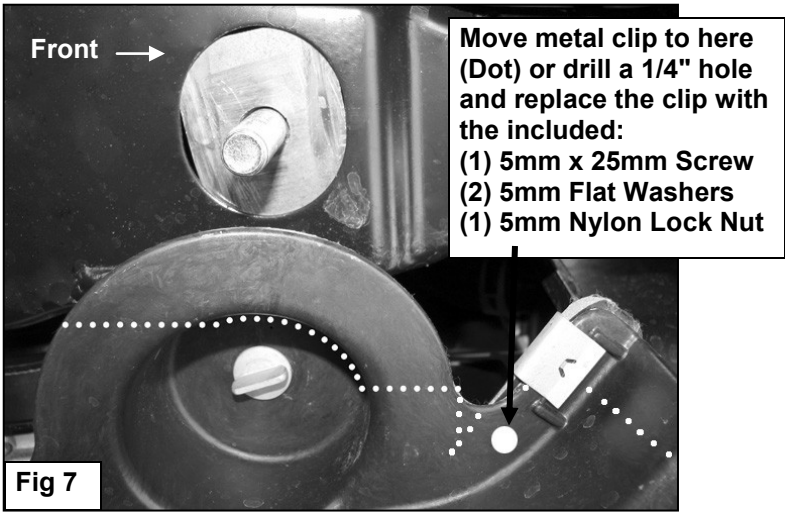

Fig 6



Thank You for choosing Westin products.



Cut as little as possible to clear brackets. Do not cut through the top or bottom edge of splash guard

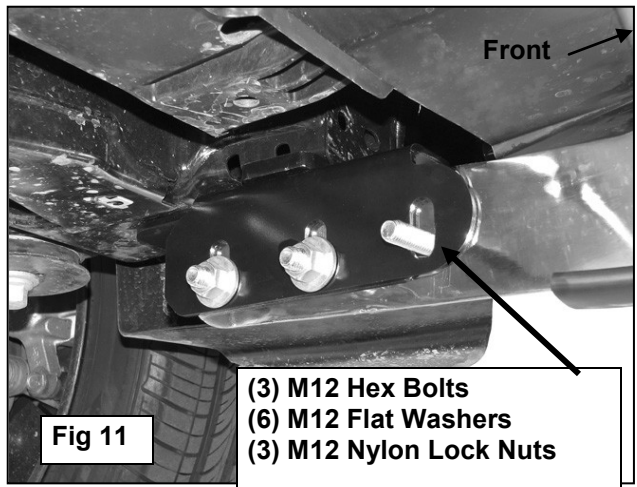
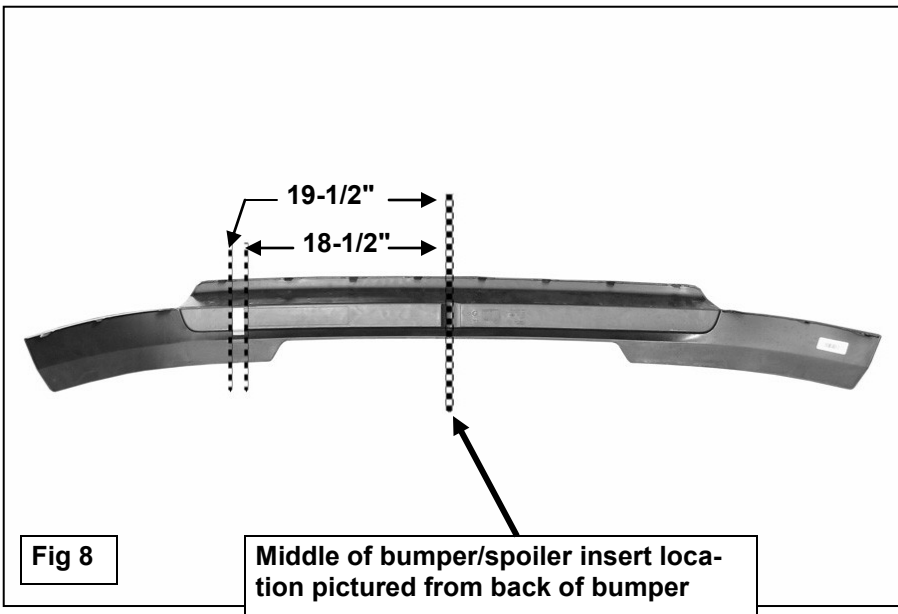
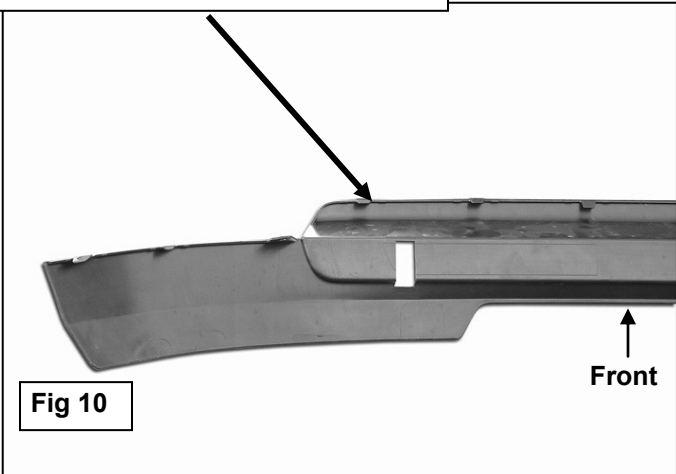

Draw lines to represent the top and the bottom of the Frame Bracket

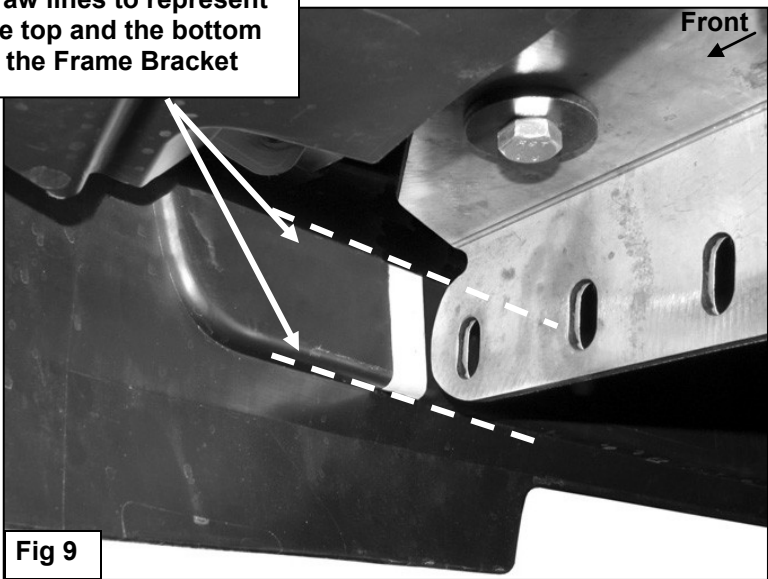

Apply a layer of removable tape to this area to mark (or mark back of cover) before cutting for Top Bracket installation (Fig 15 & 16)

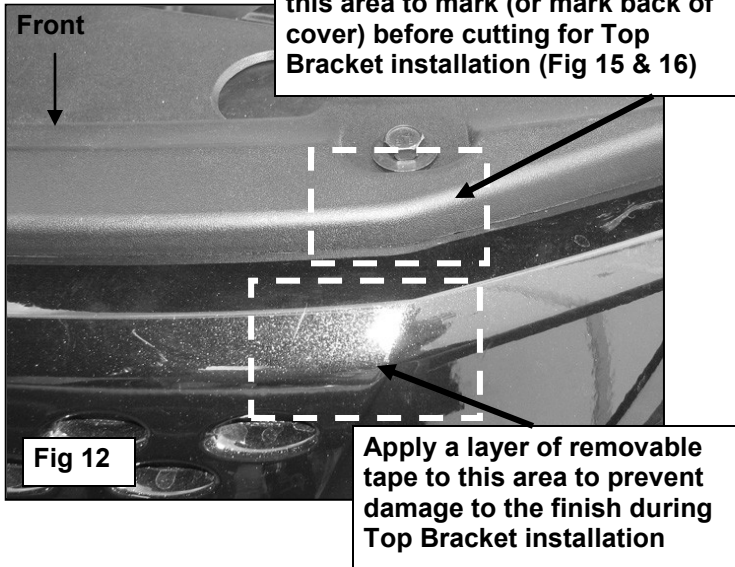

Thank You for choosing Westin products.

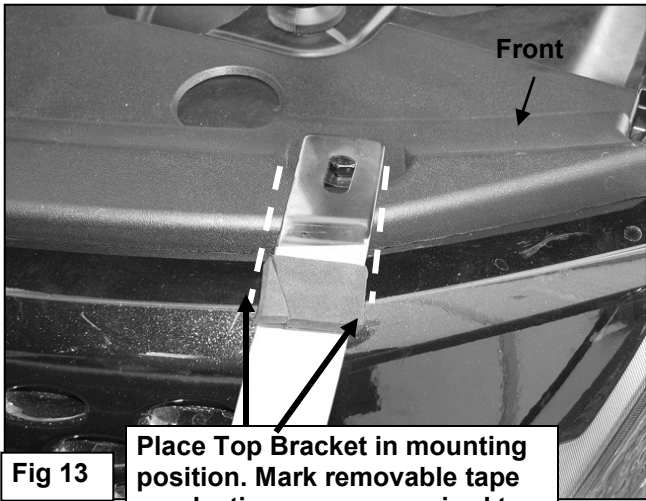

Fig 13

Place Top Bracket in mounting position. Mark removable tape on plastic cover as required to clear Top Bracket

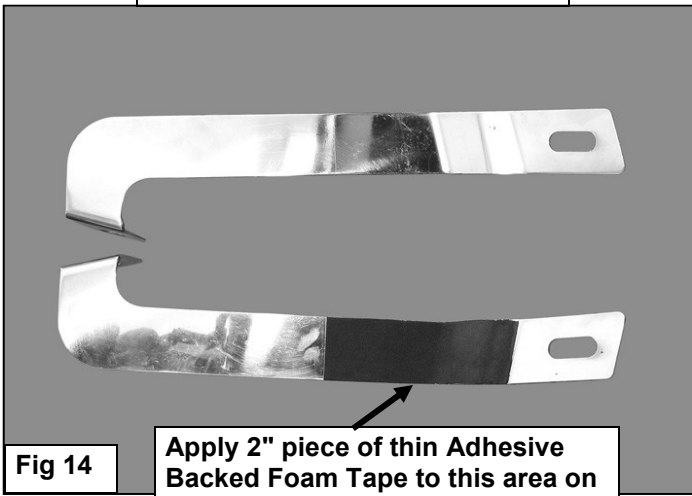
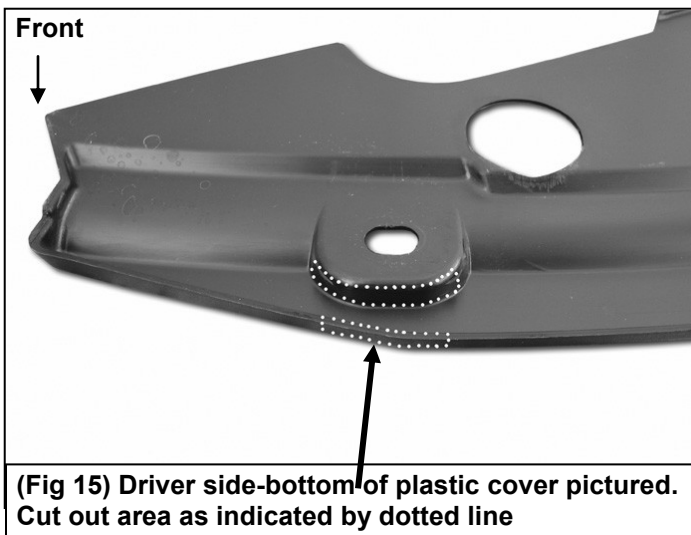
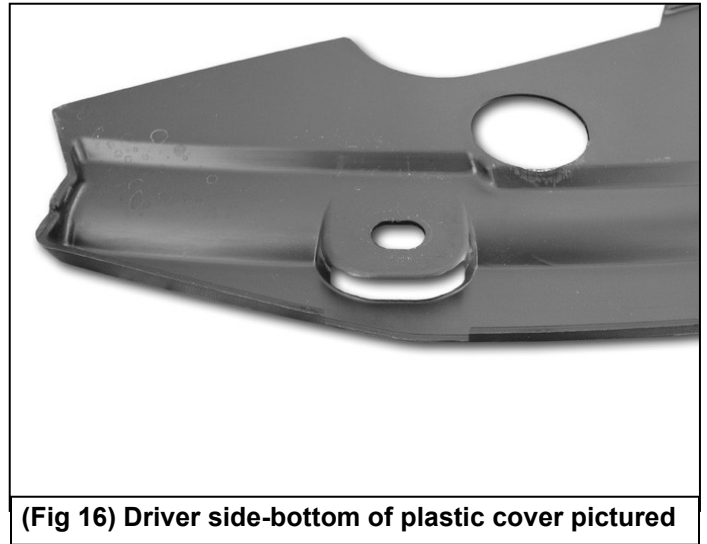

Fig 14

Apply 2" piece of thin Adhesive Backed Foam Tape to this area on the BOTTOM of both Top Brackets to prevent damage to the finish during Top Bracket installation. Trim tape to fit properly



(Fig 15) Driver side-bottom of plastic cover pictured. Cut out area as indicated by dotted line



(Fig 16) Driver side-bottom of plastic cover pictured

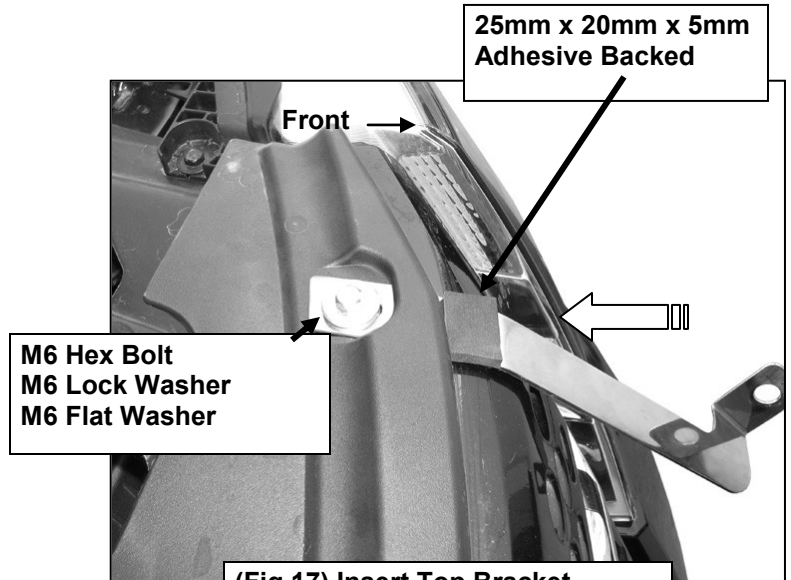

**M6 Hex Bolt
M6 Lock Washer
M6 Flat Washer**

**25mm x 20mm x 5mm
Adhesive Backed**

(Fig 17) Insert Top Bracket through opening in plastic cover

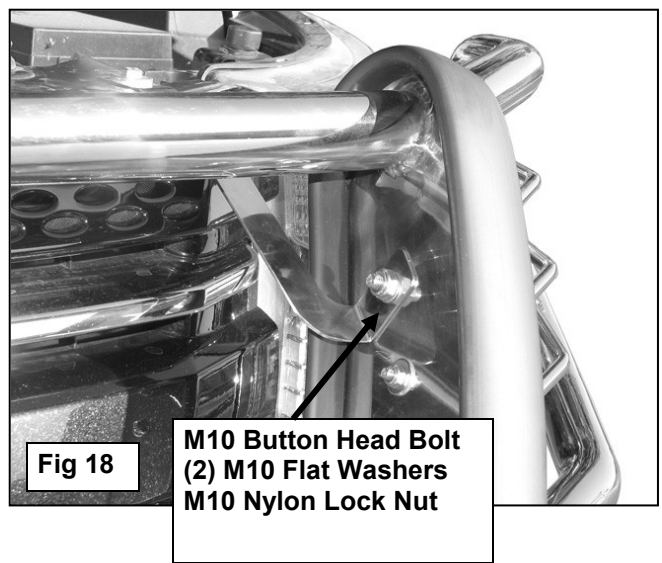

Fig 18

**M10 Button Head Bolt
(2) M10 Flat Washers
M10 Nylon Lock Nut**



Thank You for choosing Westin products.