

# INSTALLATION INSTRUCTIONS



**Sportsman Grille Guard, Sportsman X Grille Guard, HDX Grill Guard**  
**APPLICATION:**  
 2015-2020 Chevrolet Tahoe/Suburban  
**PART NUMBER:**  
 40-3805, 45-3800, 40-33805, 57-3805

CONTENT			
ITEM	QUANTITY	DESCRIPTION	TOOLS NEEDED
1	1	SPORTSMAN X GRILLE GUARD	RATCHET
2	1	UPPER MOUNTING BRACKET DRIVER SIDE	M18 SOCKET
3	1	UPPER MOUNTING BRACKET PASSEGER SIDE	M16 SOCKET
4	1	LOWER MOUNTING BRACKET DRIVER SIDE	M15 SOCKET
5	1	LOWER MOUNTING BRACKET PASSENGER SIDE	M18 WRENCH
6	6	M12 HEX HEAD FLANGE BOLT (YELLOW ZINC)	M16 WRENCH
7	6	M12 SERRATED FLANGE NUT (YELLOW ZINC)	M15 WRENCH
8	2	M10 SOCKET HEAD CAP SCREW (YELLOW ZINC)	ALLEN KEY
9	2	M10 CUPPED WASHER (YELLOW ZINC)	CUTTING TOOL
10	2	M12 HEX SOCKET BUTTON HEAD SCREW (BLACK STAINLESS)	TAPE MEASURES
11	6	M12 CUPPED WASHER (BLACK STAINLESS)	
12	6	M12 SERRATED FLANGE NUT (BLACK STAINLESS)	
13	4	M12 HEX SOCKET BUTTON HEAD SCREW (BLACK STAINLESS)	

**ANTI-SEIZE LUBRICANT MUST BE USED ON ALL STAINLESS STEEL FASTENERS TO PREVENT THREAD DAMAGE AND GALLING**

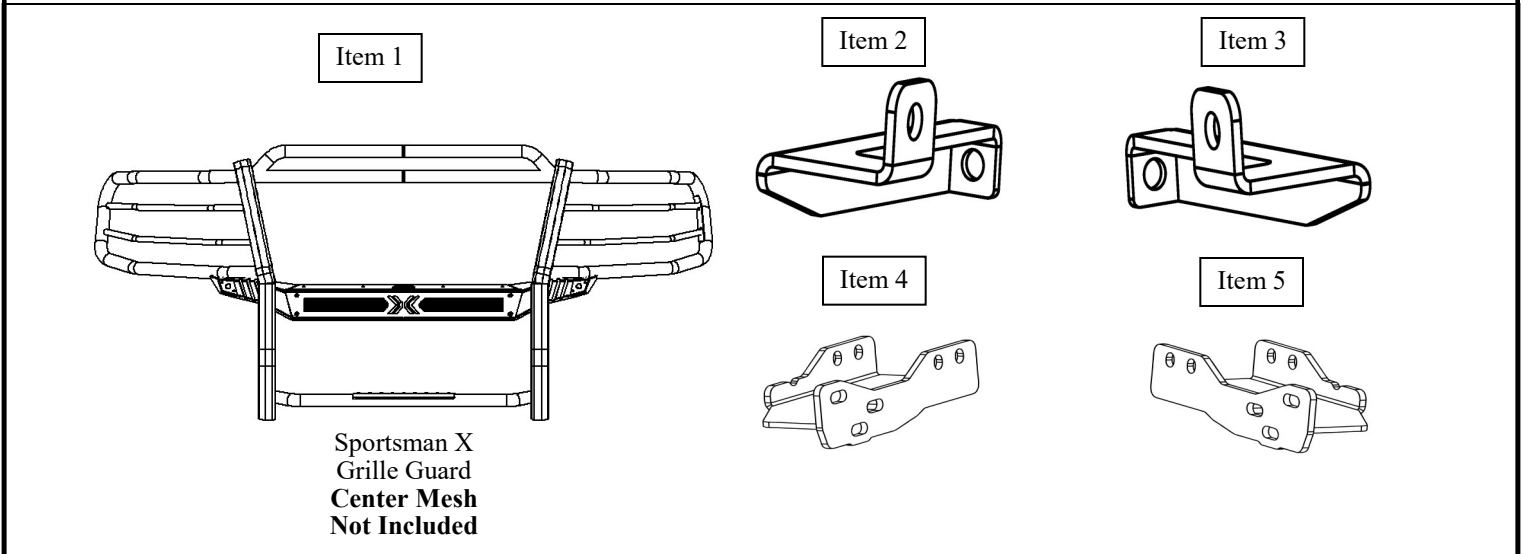

## PROCEDURE

1. Remove contents from box, verify if all parts listed are present and free from damage. Carefully read and understand all instructions before attempting installation.  
**Failure to identify damage before installation could lead to a rejection of any claim.**
2. Locate the two rectangular covers on the bumper insert. These rectangular covers will need to be removed. Trimming may be required. *Note: Some models may have factory tow hooks installed, if so, the tow hooks will have to be removed and trimming is required. See Figure 1.*
3. Locate the Template and place it on the bumper between the bumper insert and below the grille. Trim the circle on the template by using a drill motor and the 2" hole saw. See Figure 2-3.

Figure 1

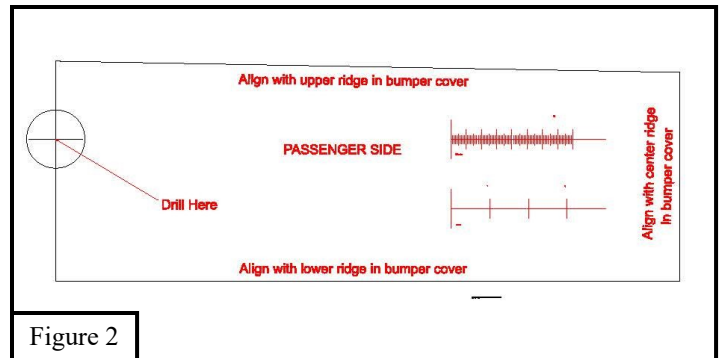
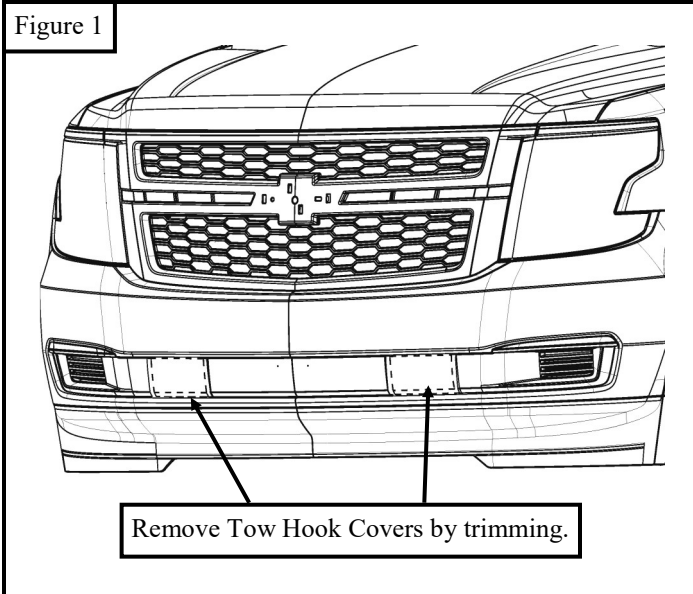
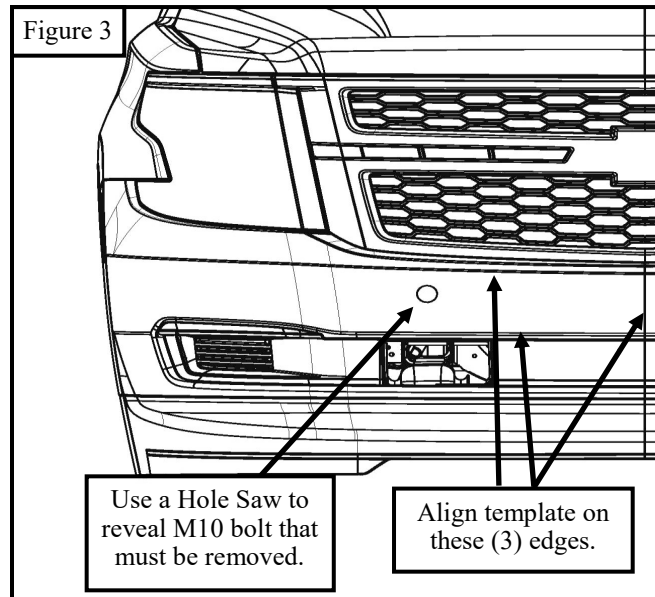
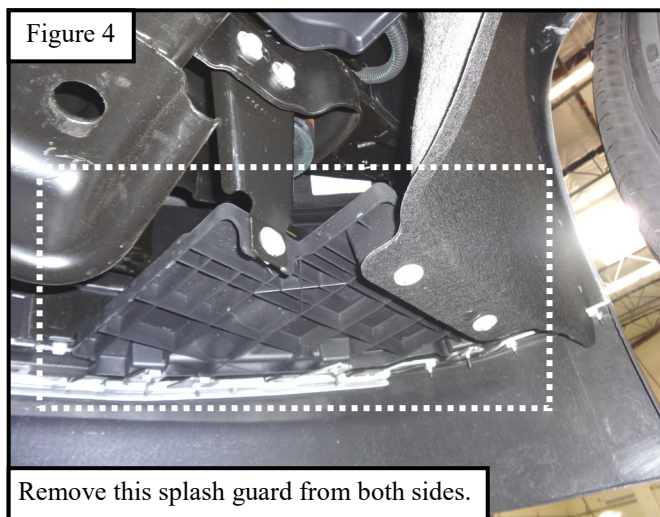

Figure 2

Figure 3



4. After drilling, locate through the hole an M10 bolt that must be removed. **See Figure 3.**
5. Locate on the underside of the front bumper, on both the passenger and the driver sides splash shields that will need to be removed. *Note: Some models may have an underbody shield that covers the engine that will have to be removed. See Figure 4.*



6. Locate the Passenger and Driver Side Lower Brackets (Item 4 and 5), and position each one where the rectangular piece is trimmed. **See Figure 5.**
7. Loosely attach the Lower Bracket by using (3) M12 Hex Head Flange Bolts (Item 6) and (3) M12 Serrated Flange Nuts (Item 7). **See Figure 6.**

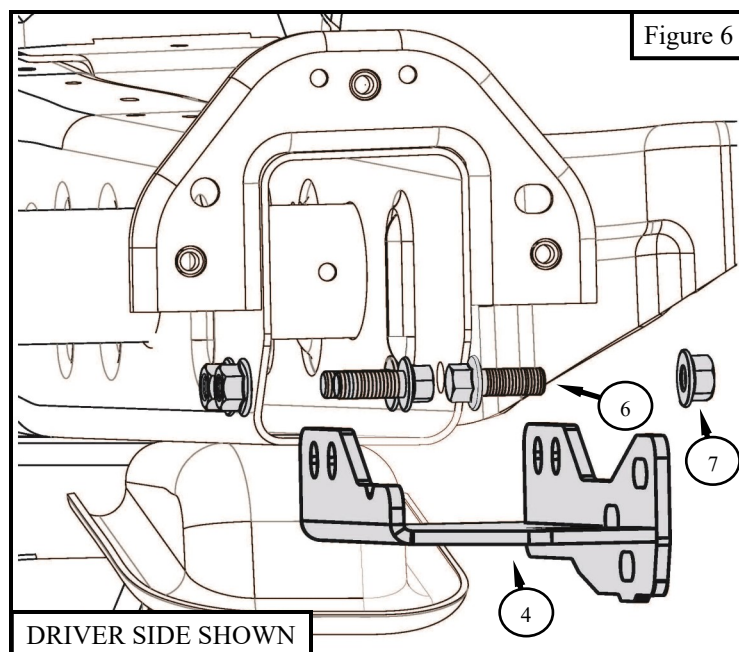
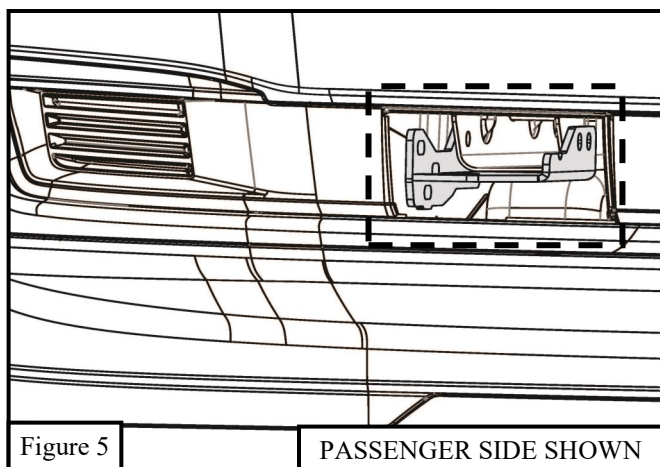

8. Locate the Upper Mounting Brackets (Items 2 and 3) and attach them to the frame where the circular 2” hole was made using the template. **See Figure 7.**
9. Loosely attach the Upper Mounting Brackets by using (2) M10 Socket Head Cap Screws (Item 8) and (2) M10 Cupped Washers (Item 9). **See Figure 8.**

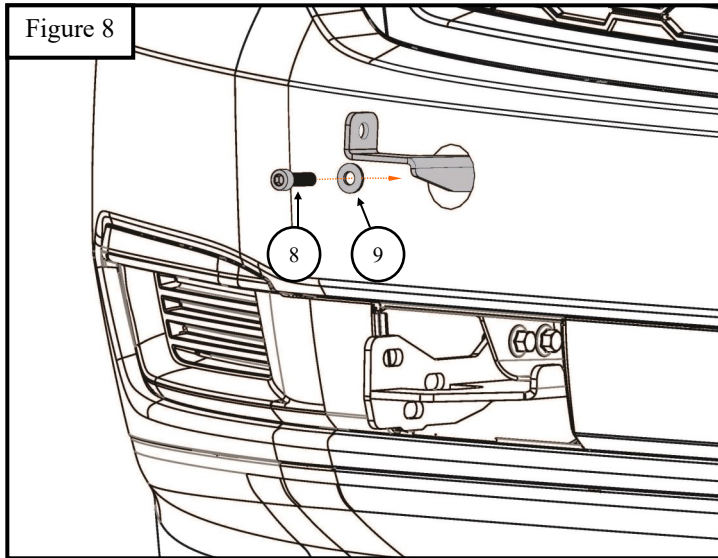
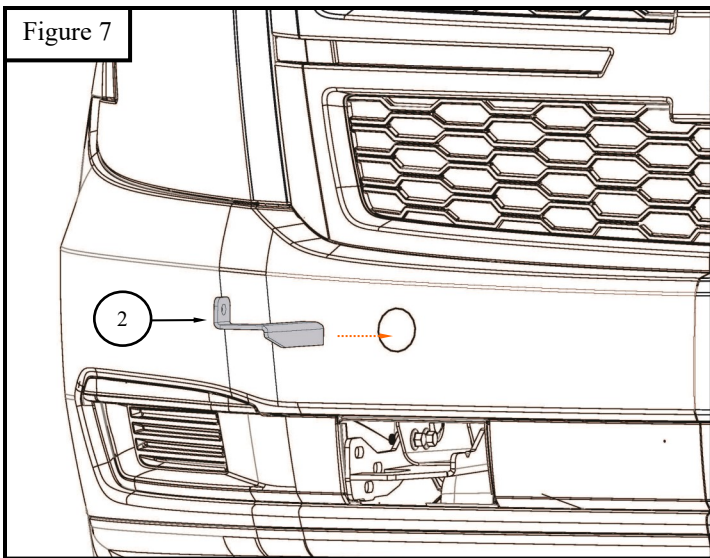

10. Locate the Grille Guard (Item 1) and align the Grille Guard with both the Bottom and Lower Mounting Brackets that were previously installed.
11. Attach the Grille Guard to the Bottom Brackets using (4) M12 Hex Socket Button Head Screws (Item 13), (4) M12 Cupped Washers (Item 11) and (4) M12 Serrated Flange Nuts (Item 12). **See Figure 9.**
12. Attach the Grille Guard to Upper Brackets using (2) M12 Hex Socket Button Head Screws (Item 10), (2) M12 Cupped Washers (Item 11) and (2) M12 Serrated Flange Nuts (Item 12). **See Figure 9.**
13. Align and adjust the Grille Guard as needed, then tighten and torque all M10 hardware to 30-35 ft-lbs. and all M12 to 50-55 ft-lbs.

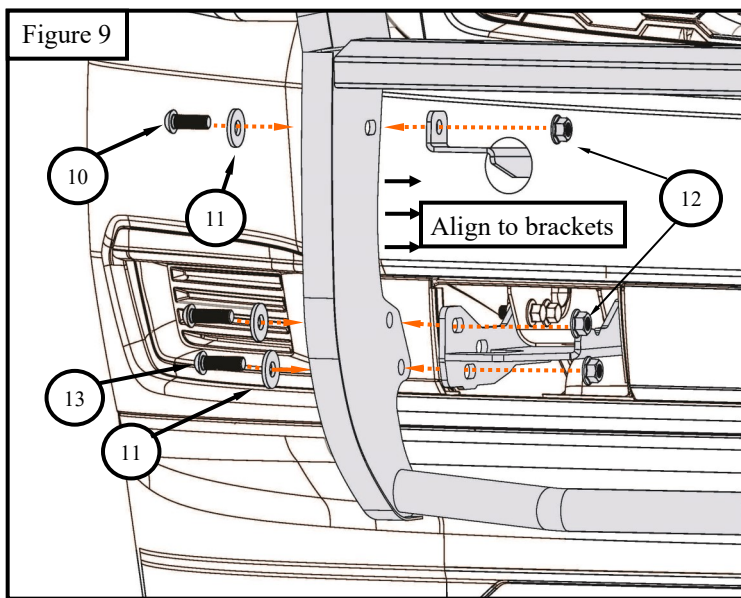



INSTALLATION COMPLETE



©2018 WESTIN AUTOMOTIVE PRODUCTS, INC. ALL RIGHTS RESERVED.

**WESTIN**

HDX Grille Guard Shown

#### CARE INSTRUCTIONS

- REGULAR WAXING IS RECOMMENDED. DO NOT USE ANY TYPE OF POLISH OR WAX THAT MAY CONTAIN ABRASIVES.
- STAINLESS STEEL PRODUCTS CAN BE CLEANED WITH MILD SOAP AND WATER. STAINLESS STEEL POLISH SHOULD BE USED TO POLISH SMALL SCRATCHES.
- GLOSS BLACK FINISHES SHOULD BE CLEANED WITH MILD SOAP AND WATER.

**WESTIN**