

INSTALLATION INSTRUCTIONS

SPORTSMAN X GRILLE GUARD



APPLICATION:
2009-2018 Ram 1500; Ram 1500 Classic 2019 (Excl. Rebel)
PART NUMBER:
40-33545

ITEM	QUANTITY	DESCRIPTION	TOOLS NEEDED
1	1	GRILLE GUARD	18MM SOCKET
2, 3	2	UPPER MOUNTING BRACKET - DRV/PASS {NOT USED FOR VEHICLES WITH FACTORY TOW HOOKS}	18MM WRENCH
4, 5	2	FRAME MOUNTING BRACKET - DRV/PASS	16MM SOCKET
6,7	2	LOWER SUPPORT STRAP - DRV/PASS	16MM WRENCH
8, 9	2	TOW POCKET SUPPORT STRAP - DRV/PASS	10MM SOCKET
10	2	M12 FINE THREAD BOLTS (YELLOW)	FLAT HEAD SCREWDRIVER
11	2	M12 COARSE THREAD BOLTS (YELLOW)	HAMMER
12	6	M12 HEX NUT (YELLOW)	TORQUE WRENCH
13	10	M12 FLAT WASHER (YELLOW)	UTILITY KNIFE
14	8	M12 LOCK WASHER (YELLOW)	ALLEN WRENCH
15	6	M12 BUTTON HEAD SCREW (BLACK / S/S)	
16	6	M12 CUPPED WASHER (BLACK / S/S)	
17	6	M12 FLANGE NUT (BLACK / S/S)	
18	2	M10 BUTTON HEAD SCREW (BLACK / S/S)	
19	2	M10 CUPPED WASHER (BLACK / S/S)	
20	2	M10 FLANGE NUT (BLACK / S/S)	

ANTI-SEIZE LUBRICANT MUST BE USED ON ALL STAINLESS STEEL FASTENERS TO PREVENT THREAD DAMAGE AND GALLING

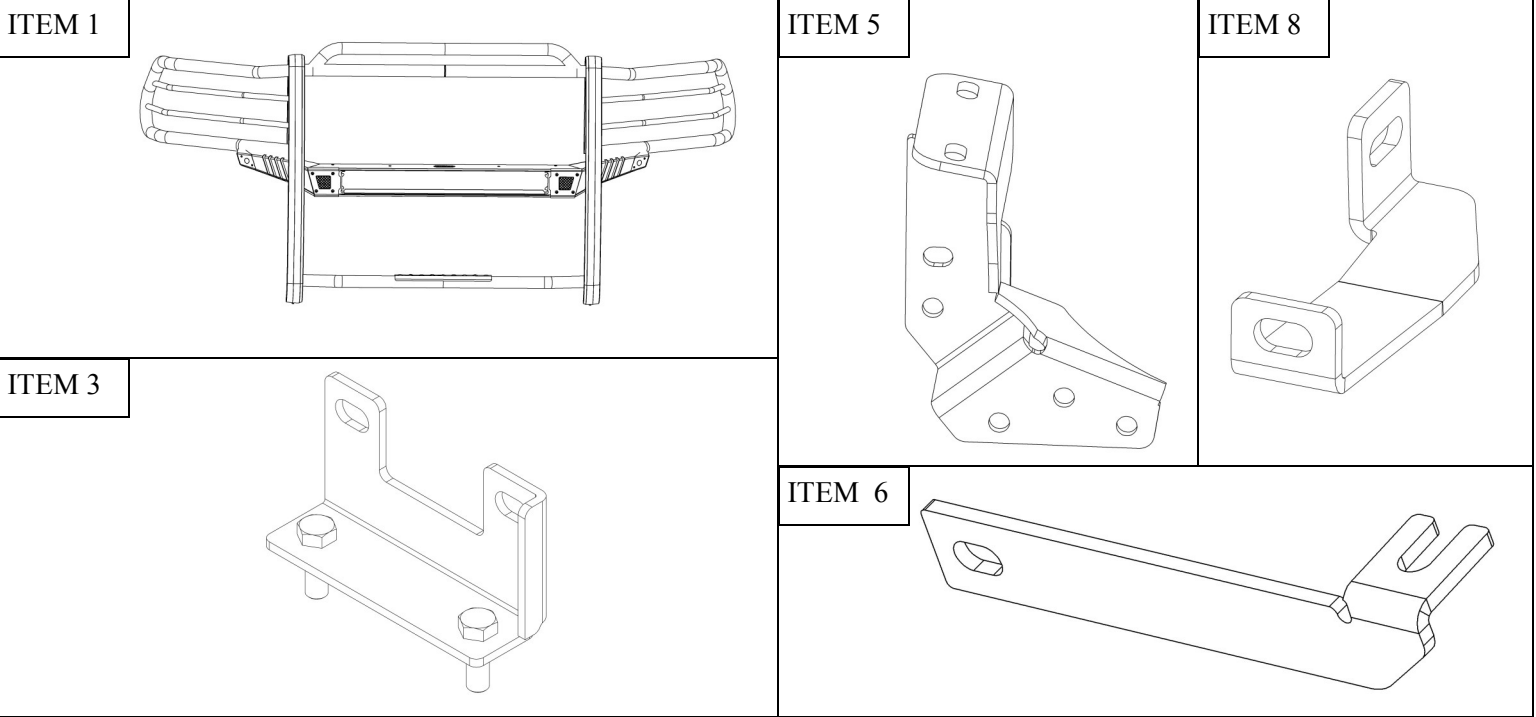

PROCEDURE

1. Remove contents from box, verify if all parts listed are present and free from damage.

Carefully read and understand all instructions before attempting installation.

Failure to identify damage before installation could lead to a rejection of any claim.

2. Remove the lower bumper front valance by removing the two M6 bolts at the ends and prying out the center pins of the plastic retaining clips with a flat head screwdriver . Note: For “Express” and “Sport” models the valance attaches differently. It may be easier to leave the valance on; trimming it as necessary in future steps to install the brackets. **See Figure 1**

3. Remove the plastic bumper “tow pocket inserts”: For 2009—2012 vehicles, remove the inserts by removing the 2-piece plastic clips at the top of the panel. **See Figures 2-4.**

Note 1: Use a flat-blade screwdriver to first pop the center pin out to release the clip. For 2013+ vehicles remove the two plastic bumper inserts that are attached with (4) M6 fasteners from the inside of the bumper. For “Express” and “Sport” vehicles pry on the molded plastic clips to pop the bumper insert loose.

Note 2: For “Express” and “Sport” vehicles it will be very difficult to completely remove the insert from the vehicle. In this case it should be slid from one side to the other in order to allow room to install the Tow Pocket Support Straps.

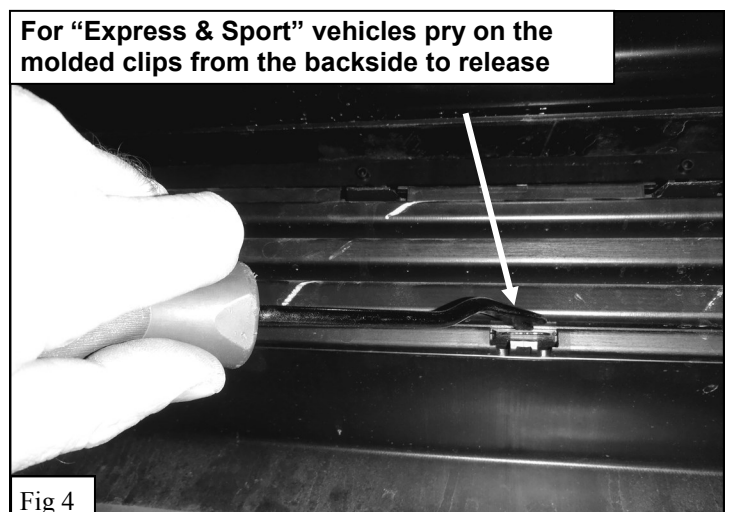
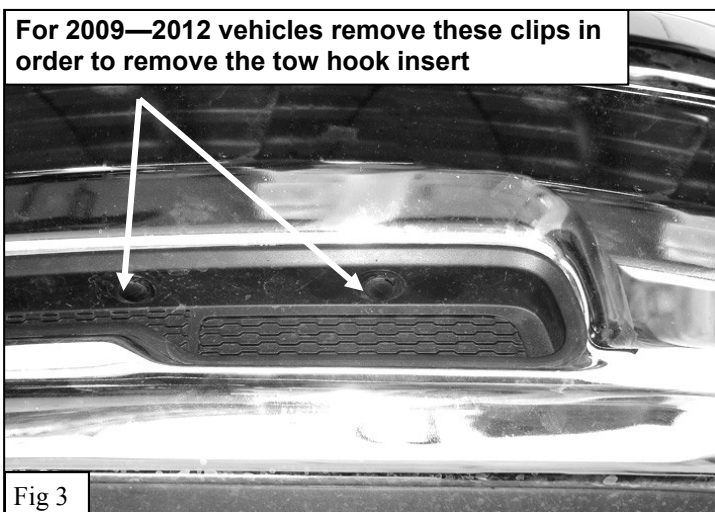
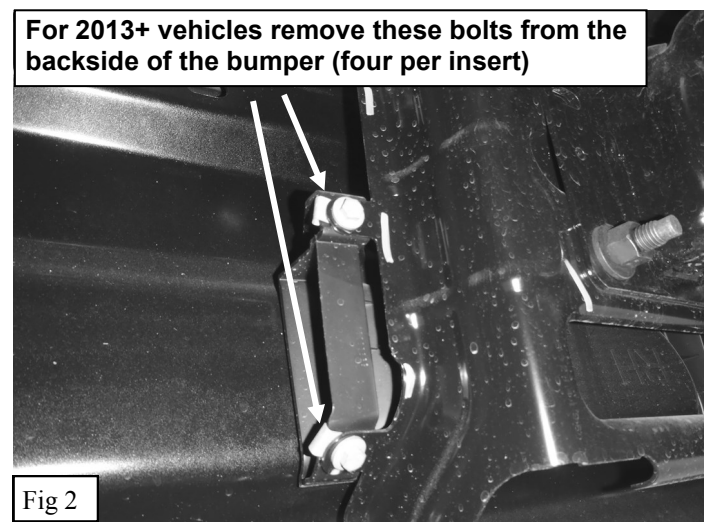
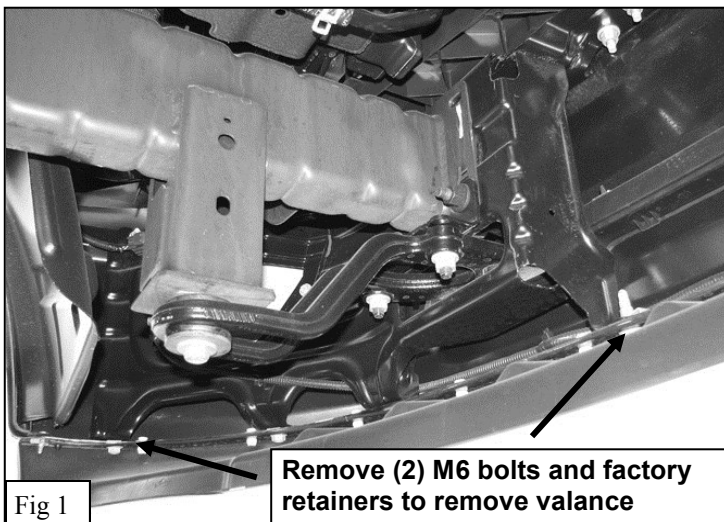

4. From behind the front bumper, remove the (2) hex nuts on the bottom of the bumper brackets securing the bumper to the frame. **See Figure 5** *Note: For vehicles with factory tow hooks it is only necessary to remove the nuts inboard toward the center of the vehicle.*
5. Drive the inboard carriage bolts in the bumper bracket out of the bracket by striking the end of the bolts with a hammer. Discard the tin retaining washers. **See Figure 6**
6. Insert the Tow Pocket Support Straps into the openings in the front of the bumper and line up the mounting hole with the slot in the bumper bracket. Re-use the factory carriage bolts and nuts to secure these brackets. Attach all hardware loosely **See Figure 7.**
7. For vehicles without factory tow hooks loosely install the Upper Mounting Bracket on the backside of the carriage bolts. **See Figure 8.**

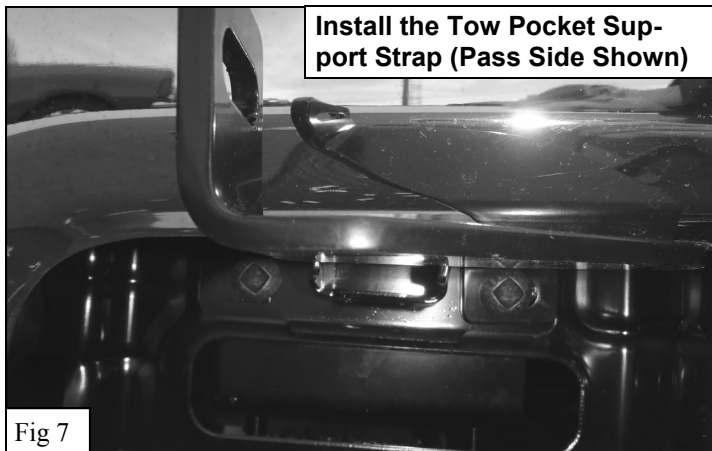
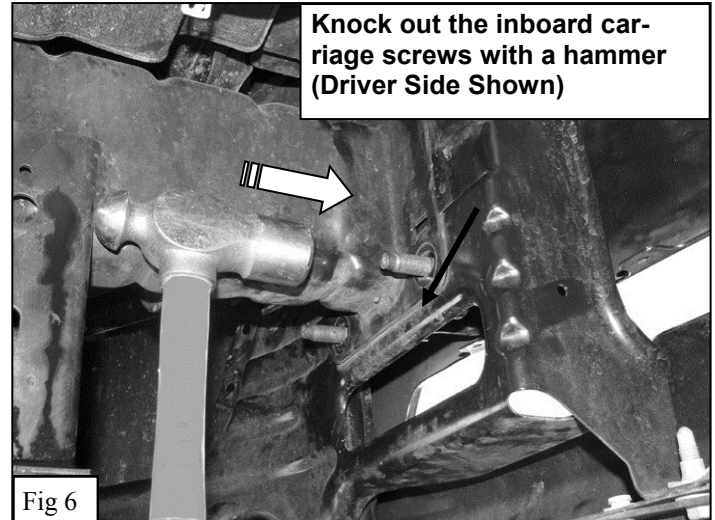
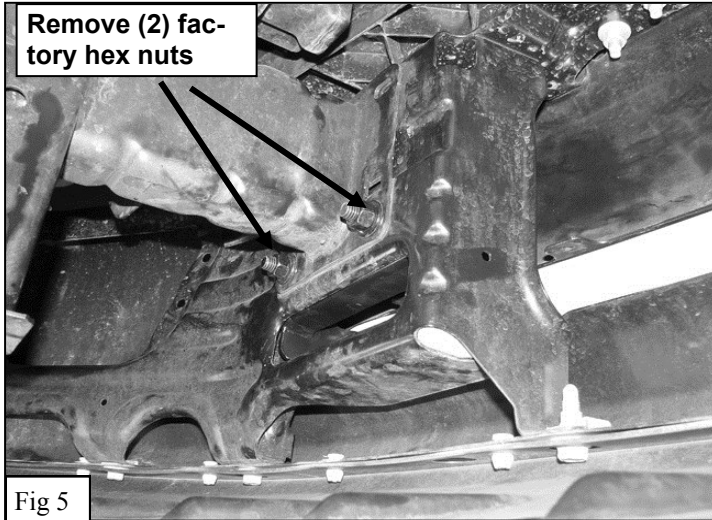

8. Loosely install the Frame Mounting Brackets and the Lower Support Straps “Express” and “Sport” vehicles may require trimming to the plastic valance support. For vehicles with factory tow hooks re-use the factory hardware at the tow hook mounting points and the Coarse Thread M12 Hardware to attach the Lower Support Strap to the Frame Mounting Brackets. For vehicles without factory tow hooks use the Fine Thread M12 Hardware to mount the rear of the Lower Support Strap to the frame pillar and the Coarse Thread M12 Hardware to attach the Lower Support Strap to the Frame Mounting Brackets
See Figures 9-10
9. With assistance, lift the Grille Guard and loosely attach it to the mounting brackets. Use the M12 Button Head Hardware to attach to the Frame Mount Brackets and the M10 Button Head Hardware to attach the Tow Pocket Support Straps **See Figure 11**

Mounting Bracket Installation — Vehicles w/o Tow Hooks (Drv Side Shown)

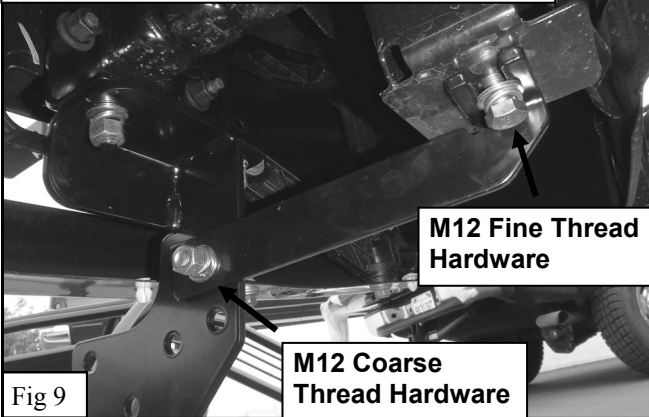

Fig 9

Mounting Bracket Installation — Vehicles with Tow Hooks (Pass Side Shown)

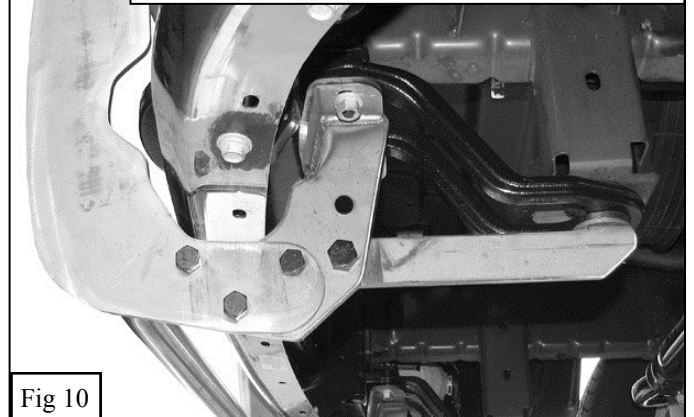

Fig 10

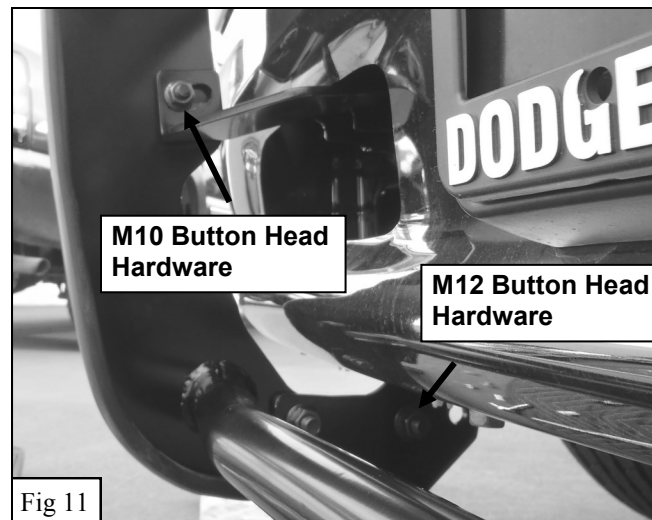
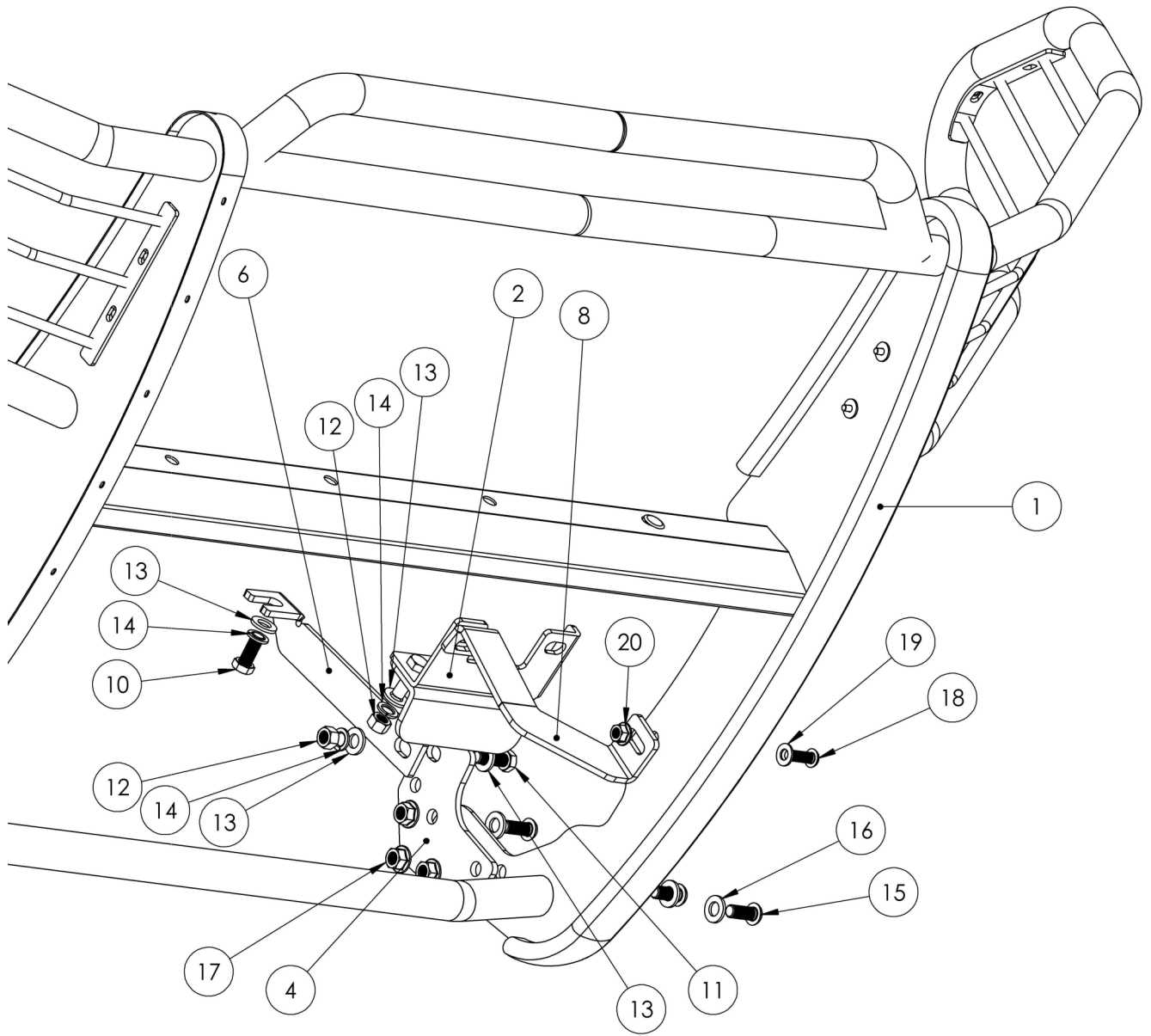

Fig 11

10. Trim the lower valance and tow pocket inserts to fit around the mounting brackets and re-install using factory hardware.
11. Align and adjust the Grille Guard as necessary then torque all M12 fasteners to 45-50 ft lbs, M10 to 30-35 ft lbs.



Exploded View

Installation Complete



CARE INSTRUCTIONS

- REGULAR WAXING IS RECOMMENDED. DO NOT USE ANY TYPE OF POLISH OR WAX THAT MAY CONTAIN ABRASIVES.
- STAINLESS STEEL PRODUCTS CAN BE CLEANED WITH MILD SOAP AND WATER. STAINLESS STEEL POLISH SHOULD BE USED TO POLISH SMALL SCRATCHES.
- GLOSS BLACK FINISHES SHOULD BE CLEANED WITH MILD SOAP AND WATER.

WESTIN



WARNING



Failure to follow these instructions could lead to death, personal injury, and / or property damage.

Failure to follow these instructions could lead to death, personal injury, and / or property damage.

FASTENERS:

All Westin supplied fasteners must be utilized and installed in accordance with the installation instructions and apply torque to the specifications as defined. **DOUBLE CHECK ALL FASTENERS BEFORE INITIAL USE, AND PERIODICALLY IN THE FUTURE TO ENSURE PROPER FUNCTION AND SAFETY.**

DRILLING:

Most Westin products do not require drilling for installation. If drilling is defined as required, use caution when drilling a vehicle. **FAILURE TO REVIEW AN AREA TO BE DRILLED MAY RESULT IN PERSONAL INJURY AND/OR INJURY TO OTHERS AS WELL AS VEHICLE DAMAGE.**

EYE PROTECTION:

ALWAYS WEAR SAFETY GLASSES OR GOGGLES DURING THE INSTALLATION PROCESS TO AVOID PERSONAL INJURY.

MAXIMUM TOWING/CARRYING CAPACITY: (if applicable)

The Westin Receiver Hitches will have a visible tow rating label affixed directly on the product. User should never exceed the vehicle manufacturers maximum tow and weight rating regardless of the capacity of the hitch. **FAILURE TO FOLLOW THESE GUIDELINES WILL VOID THE WESTIN WARRANTY AND MAY RESULT IN PERSONAL INJURY AND/OR INJURY TO OTHERS AS WELL AS VEHICLE DAMAGE.**

FOR CALIFORNIA RESIDENTS ONLY-PROP 65 WARNING:

Some products may contain chemicals such as DEHP, which can cause cancer, birth defects or other reproductive harm.

