

# INSTALLATION INSTRUCTIONS

Sportsman and Sportsman X Grille Guard



APPLICATION:

2012– 2019 Nissan Frontier

PART NUMBER:

40-2075, 45-2070, 40-32075

ITEM	QUANTITY	DESCRIPTION	TOOLS NEEDED
1	1	GRILLE GUARD	RATCHET
2,3	2	LOWER BRACKET (DRIVER & PASSENGER)	ALLEN KEY
4,5	2	UPPER SUPPORT STRAP (DRIVER & PASSENGER)	16mm SOCKET
6	2	M10-1.50 NUT PLATE	17mm SOCKET
7	2	SHORT SPACER	18mm SOCKET
8	2	M10-1.50 x 45mm HEX HEAD CAP SCREW (Yellow Zinc)	16mm WRENCH
9	2	M10 FLAT WASHER (Yellow Zinc)	17mm WRENCH
10	2	M10 LOCK WASHER (Yellow Zinc)	18mm WRENCH
11	2	M10-1.50 x 30mm HEX SOCKET BUTTON HEAD SCREW (S/S) *	TORQUE WRENCH
12	2	M10 CUPPED WASHER (S/S) *	
13	2	M10-1.50 SERRATED FLANGE NUT (S/S) *	
14	6	M12-1.75 x 30mm HEX SOCKET BUTTON HEAD SCREW (S/S) *	
15	6	M12 CUPPED WASHER (S/S) *	
16	6	M12 SERRATED FLANGE NUT (S/S) *	
17	4	M12-1.25 x 35mm HEX HEAD CAP SCREW (Yellow Zinc)	
18	4	M12 LOCKWASHER (Yellow Zinc)	
19	4	M12 FLAT WASHER (Yellow Zinc)	

(S/S)= STAINLESS STEEL, \*=FOR 40-2075 BLACK ZINC PLATED S/S

**ANTI-SEIZE LUBRICANT MUST BE USED ON ALL STAINLESS STEEL FASTENERS TO PREVENT THREAD DAMAGE AND GALLING.**

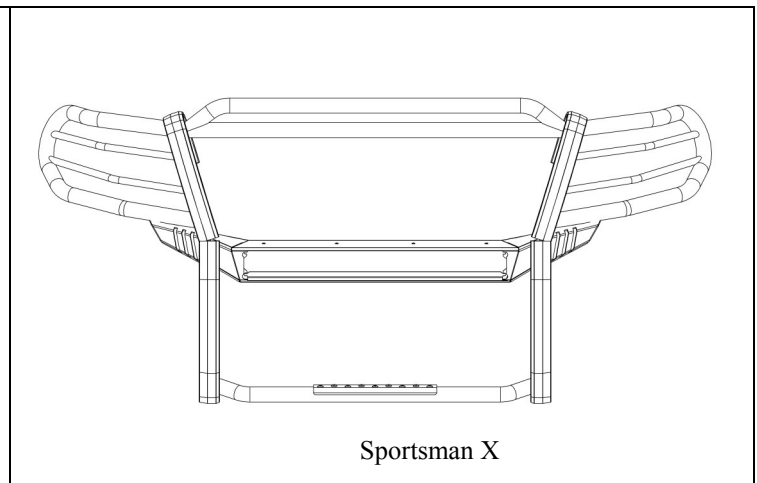
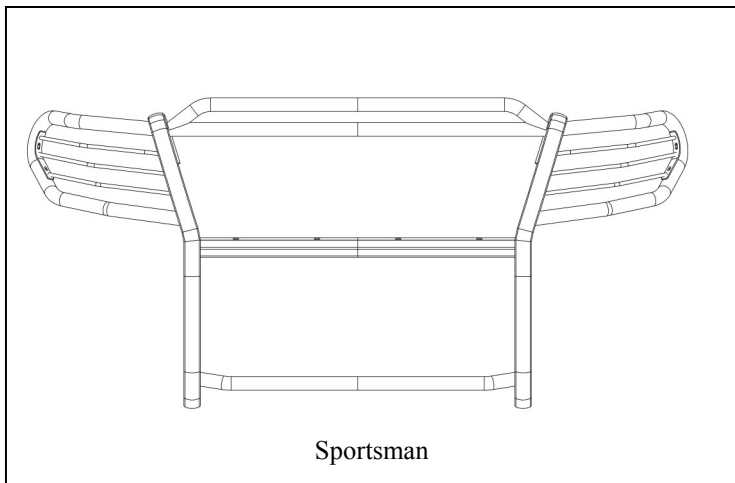

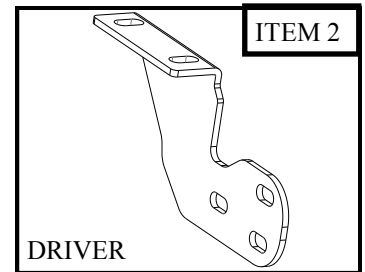
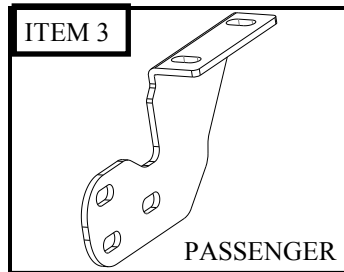
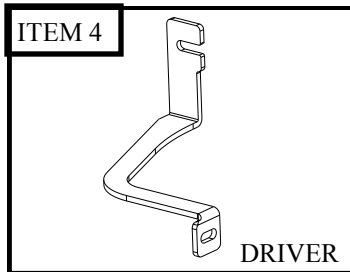
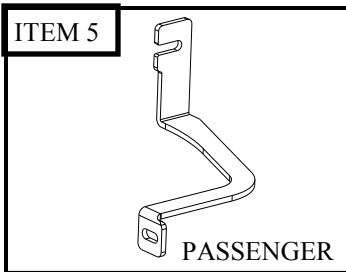

### PROCEDURE

1. Remove contents from box, verify if all parts listed are present and free from damage. Carefully read and understand all instructions before attempting installation.  
**Failure to identify damage before installation could lead to a rejection of any claim.**
2. On the front of the vehicle, locate on the underside of the vehicle frame the body chassis that has two threaded holes per side. (Figure 1) *Note: If equipped remove the factory tow hooks. Tow hooks cannot be re-used.*
3. Loosely attach the Lower Brackets (item 2 &3) to each side of the frame, using (4) M12 fine thread hex head cap screws (item 17), (4) M12 lock washers (item 18), and (4) M12 flat washers (item 19). (Figure 2)

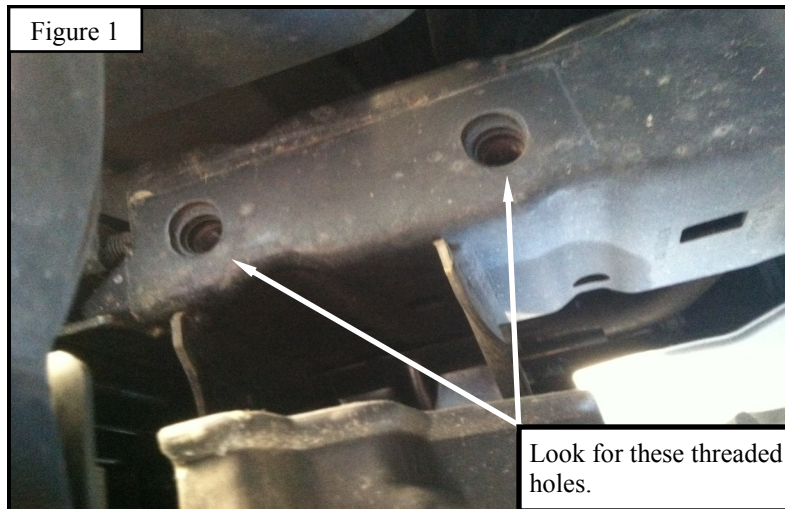

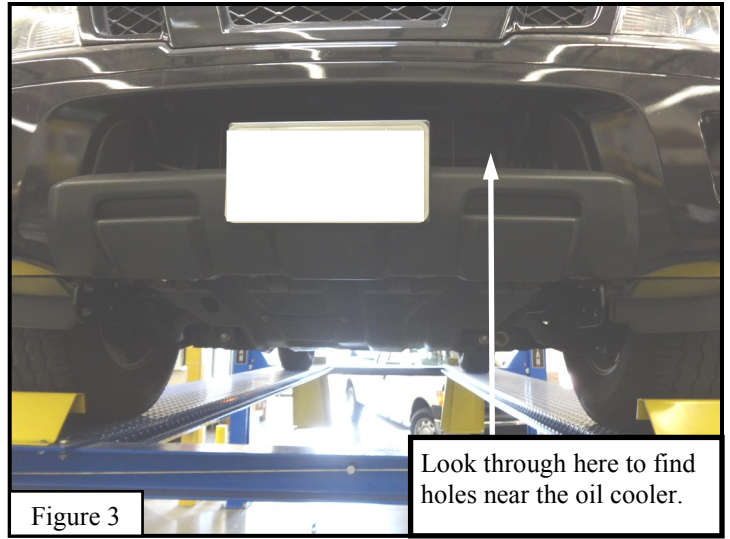
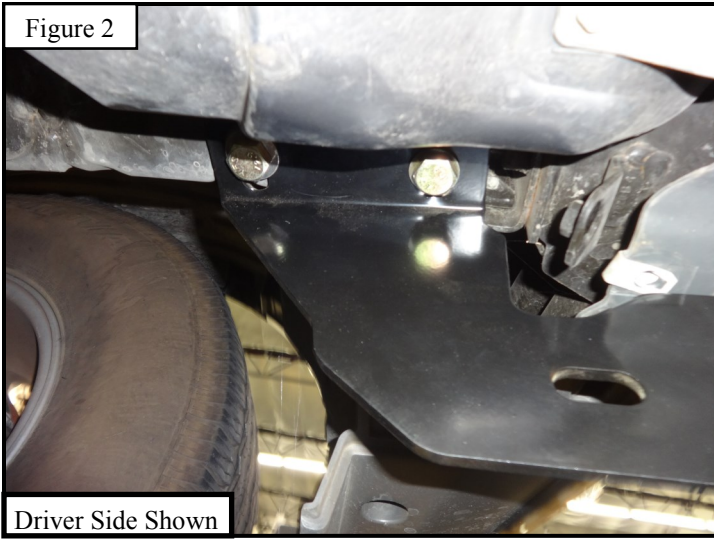

4. Proceed to locate through the front bumper, under the oil coolers, a set of holes. (Figures 3& 4)
5. Through the back side of the holes attach loosely the M10 nut plates (item 6) then proceed to install per side, (1) short spacer (item 7), (1) M10 flat washer (item 9), (1) M10 lock washer (item 10), and (1) M10 hex head cap screw (item 8). (Figures 4 & 5)

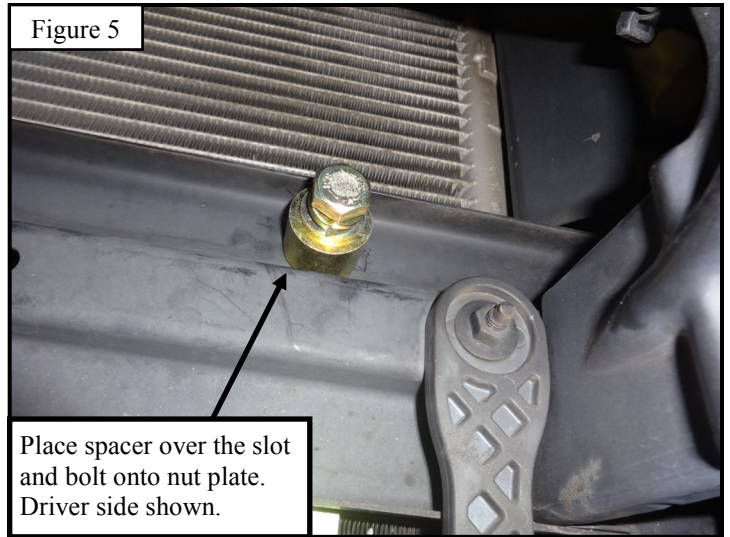
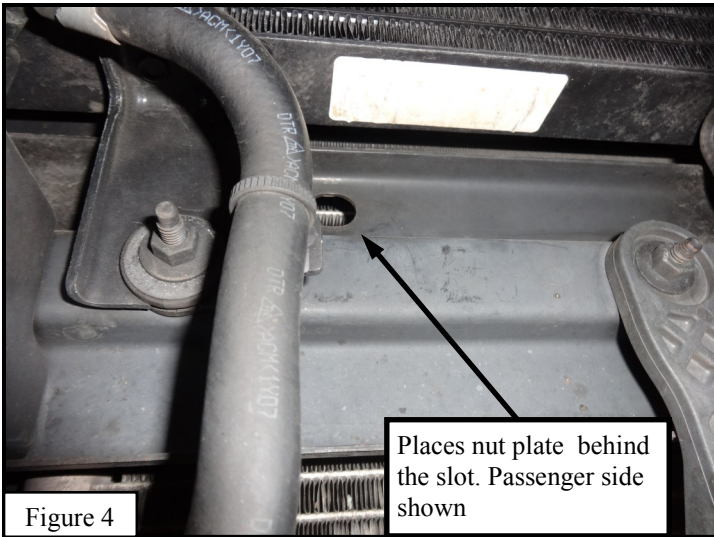

6. In between items 5 and item 7 on the previously attached spacers, slide the fork side of the upper support strap (items 2 & 3) to both driver and passenger side. (Figure 6)

Figure 6

Slide fork side of the bracket here.

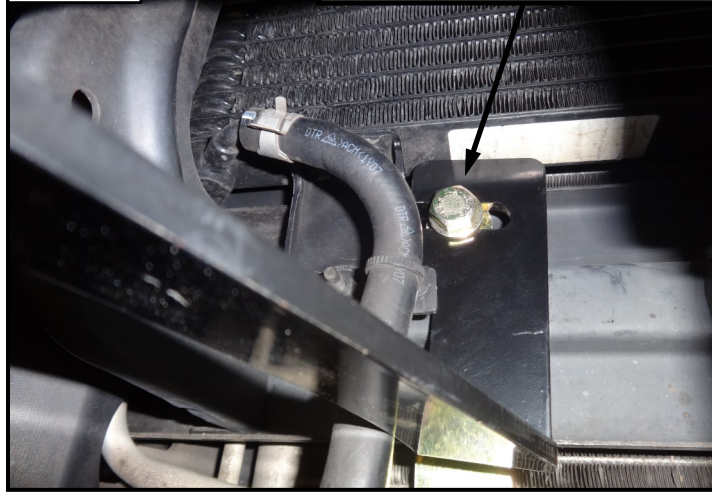

7. Align the Sportsman Grille Guard (item 1) to the bottom brackets so that the brackets align inside the grille guard. Attach to the bottom brackets using (6) M12 hex socket button head screws (item 14), (6) M12 cupped washers (item 15), and (6) M12 serrated flange nuts (item 16).
8. To attach top support brackets use (2) M10 hex socket button head screw (item 11), (2) M10 cupped washers (item 12), and (2) M10 serrated flange nuts (item 13). (Figures 7, 8 & 9)
9. Adjust the grille guard as necessary and tighten all M10 bolts to 25 to 30 ft-lbs and all M12 to 50-55 ft-lbs.

Figure 7

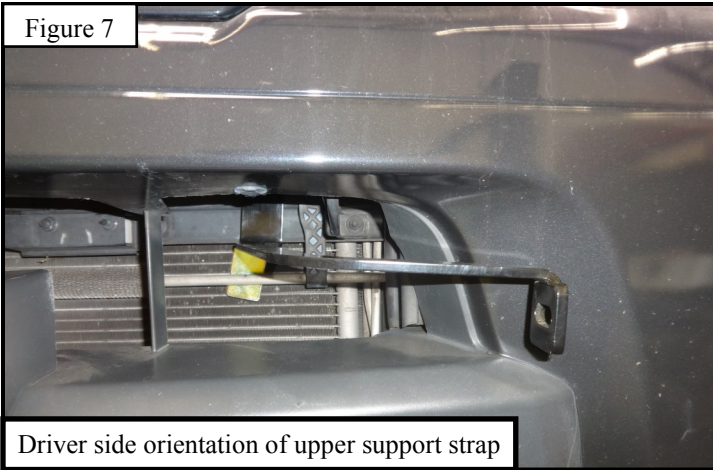
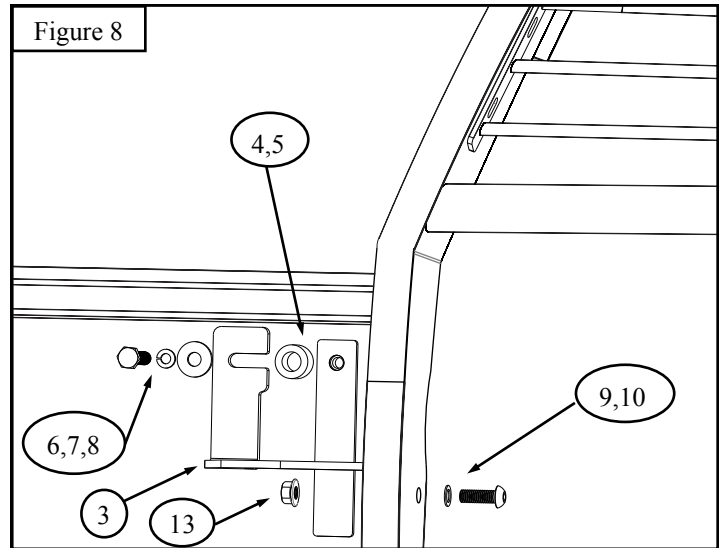
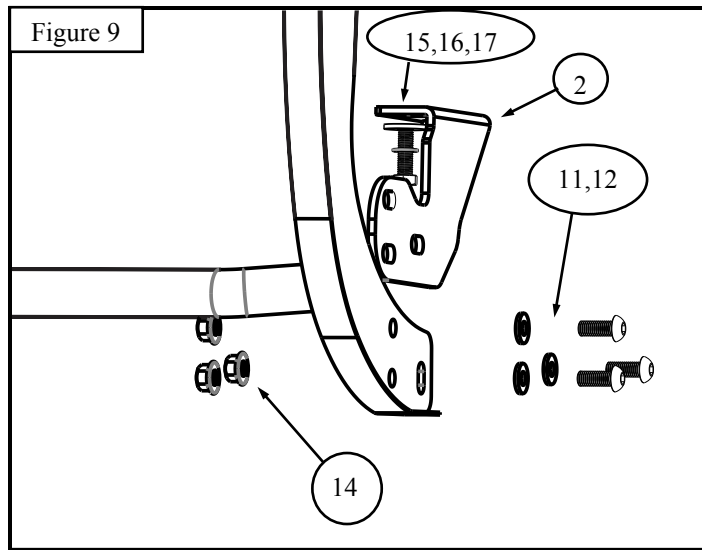

Figure 8







INSTALLATION COMPLETE



©2019 WESTIN AUTOMOTIVE PRODUCTS, INC. ALL RIGHTS RESERVED

**CARE INSTRUCTIONS**

- REGULAR WAXING IS RECOMMENDED. DO NOT USE ANY TYPE OF POLISH OR WAX THAT MAY CONTAIN ABRASIVES.
- STAINLESS STEEL PRODUCTS CAN BE CLEANED WITH MILD SOAP AND WATER. STAINLESS STEEL POLISH SHOULD BE USED TO POLISH SMALL SCRATCHES.
- GLOSS BLACK FINISHES SHOULD BE CLEANED WITH MILD SOAP AND WATER.

**WESTIN**