



INSTALLATION INSTRUCTIONS

2011-2015 F250/350 SUPERDUTY
PART NUMBER: 45-2370, 40-2375
SPORTSMAN GRILLE GUARD

AUTOMOTIVE PRODUCTS, INC.

ITEM	QUANTITY	DESCRIPTION	TOOLS NEEDED
1	1	SPORTSMAN GRILLE GUARD	18MM SOCKET
2	1	DRIVER FRAME MOUNTING BRACKET	18MM WRENCH
3	1	PASSENGER FRAME MOUNTING BRACKET	RATCHET
4	1	DRIVER LOWER MOUNTING BRACKET	TORQUE WRENCH
5	1	PASSENGER LOWER MOUNTING BRACKET	UTILITY KNIFE
6	10	M12-1.75X35MM HEX HEAD BOLTS (STAINLESS STEEL)	
7	12	M12 LARGE FLAT WASHERS (STAINLESS STEEL)	
8	8	M12 SMALL FLAT WASHERS (STAINLESS STEEL)	
9	10	M12 SPRING LOCK WASHERS (STAINLESS STEEL)	
10	10	M12 HEX NUTS (STAINLESS STEEL)	

ANTI-SEIZE LUBRICANT MUST BE USED ON ALL STAINLESS STEEL FASTENERS TO PREVENT THREAD DAMAGE AND GALLING

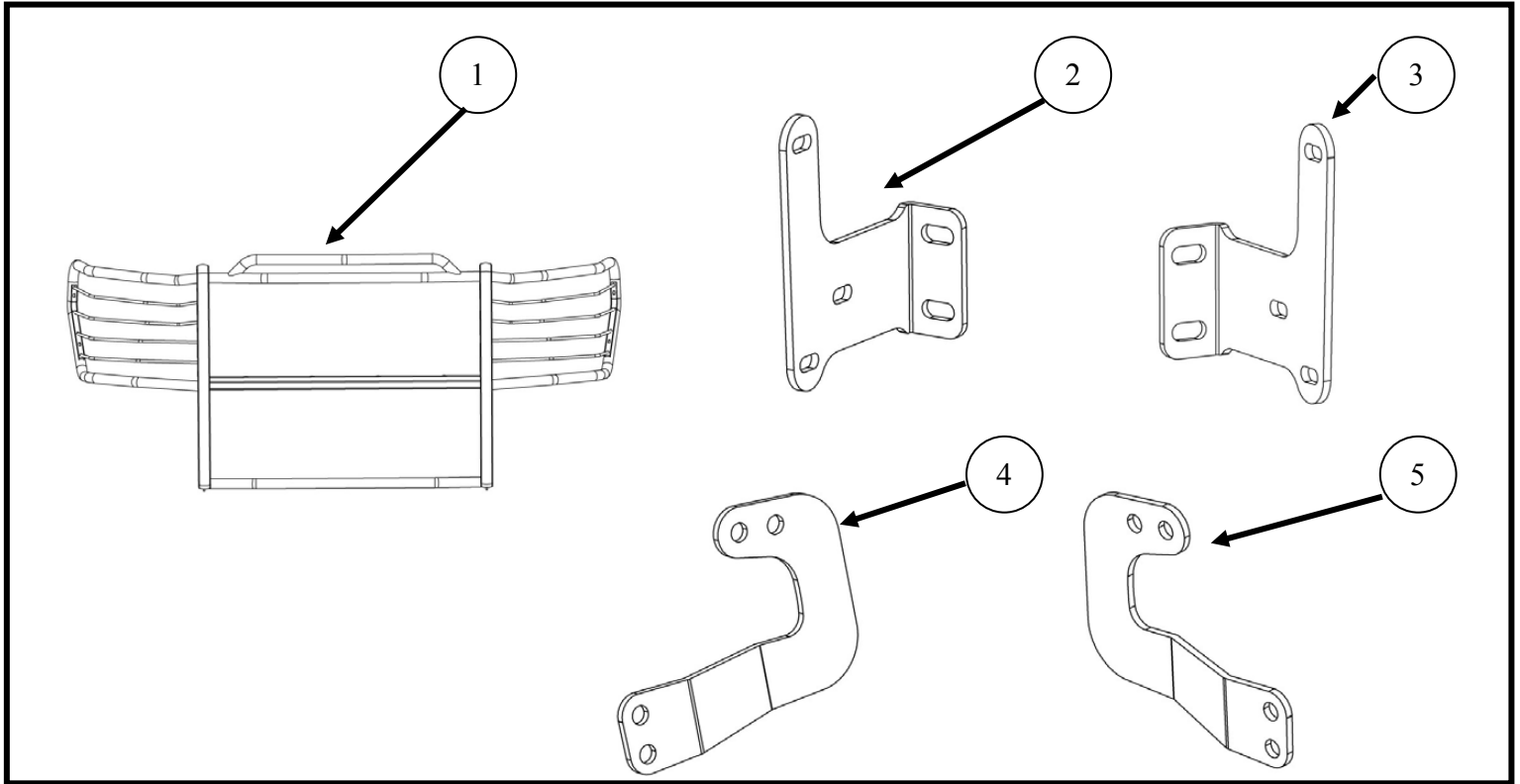

Thank You for choosing Westin products.

PROCEDURE

1. Remove contents from box, verify if all parts listed are present and free from damage. Carefully read and understand all instructions before attempting installation. **Failure to identify damage before installation could lead to a rejection of any claim.**
2. Before beginning installation, measure the gap between the headlight assembly and the bumper cover on both sides of the vehicle (**Figure 1**). Also note the gap between the grille shell and the bumper cover. Record these measurements as the installation requires removal of the bumper bolts and you will need these measurements to properly re-adjust the bumper height to its original position.

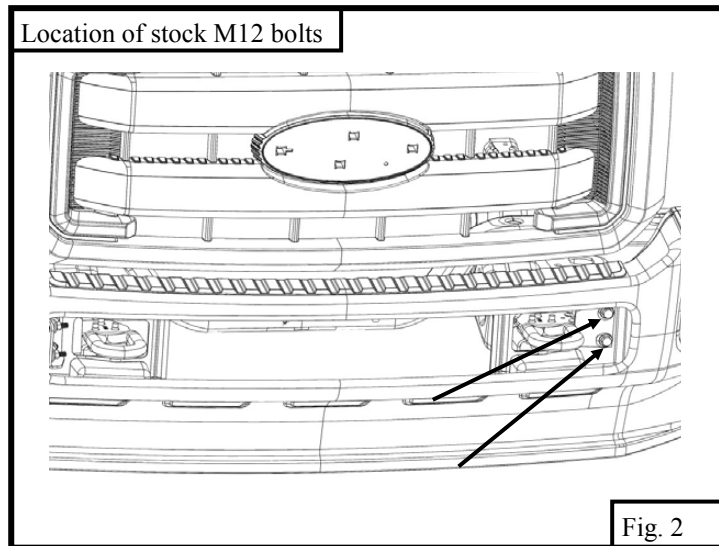
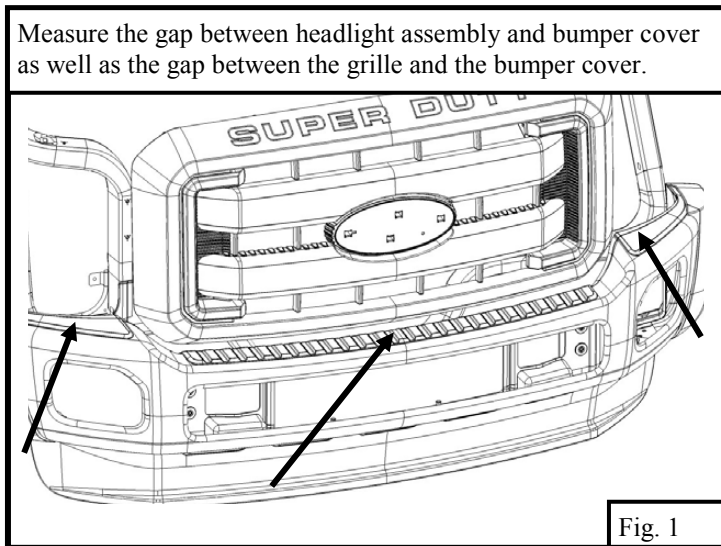

3. Start installation on the driver side of the vehicle. Locate the two stock M12 bolts and remove them (**Figure 2**). **WARNING!** Do not remove passenger and driver bumper bolts at the same time or the bumper may fall. **NOTE:** There are retainer clips that may need to be pried off the bolts.
4. Position the driver frame bracket up against the frame of the vehicle, making sure to align the two holes of the bracket with those of the frame. Loosely install the frame mounting bracket to the vehicle using the factory bolts and double nut plate (**Figure 3**). Check bumper alignment, then fully tighten these two bolts. **NOTE:** It may be necessary to loosen and re-adjust the bumper once the grille guard has been installed.

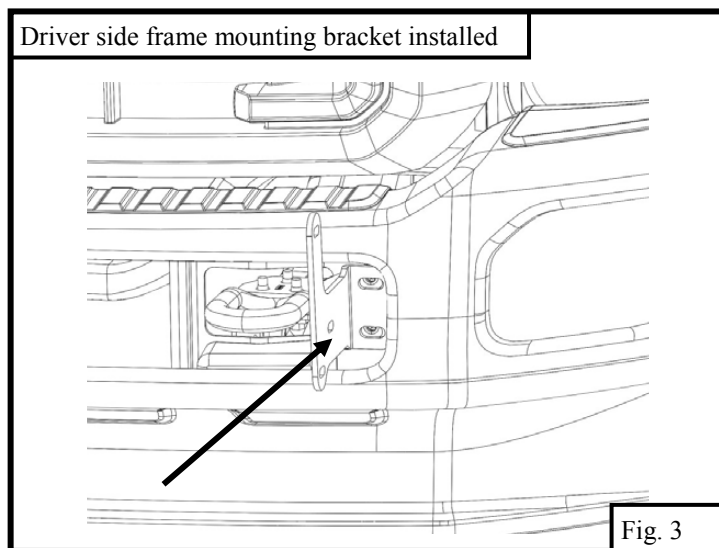

- Remove the license plate, license plate bracket, and the plastic air dam from the bottom of the bumper. Take note of the location and type of factory hardware for proper re-installation. In order to release the two-piece plastic clips, pry the center pin up with a small flat blade screwdriver (**FIG 4**).
- From under the driver side of the bumper, remove the (2) factory hex nuts on the outside of the frame channel (**Figure 5**). **NOTE: Do not allow the double bolt plate to fall into the frame channel.** Position the driver side lower mounting bracket up against the frame channel, making sure to align the holes of the bracket with those of the channel. Loosely install the bracket to the factory double bolt plate and secure it with the two factory hex nuts (**Figure 6**).

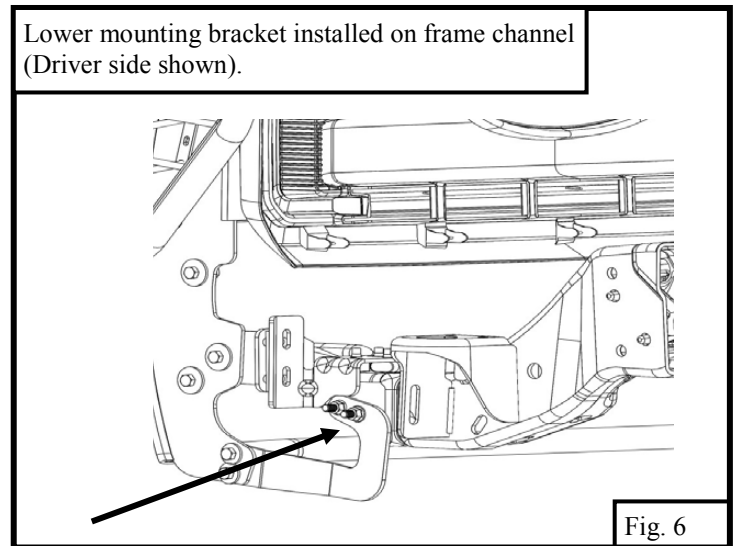
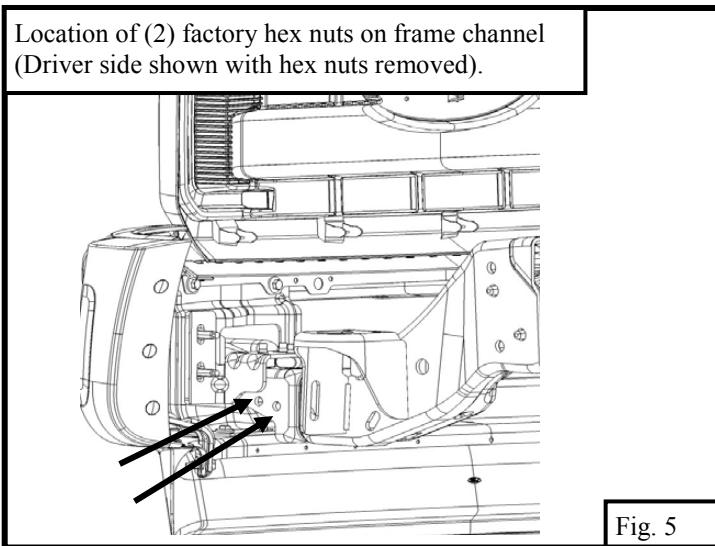
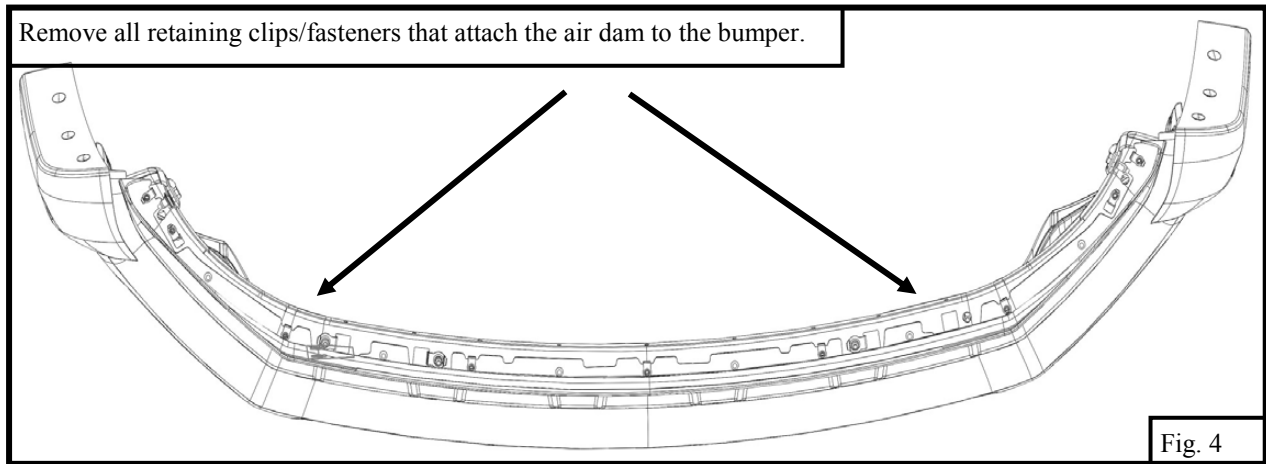

- Repeat steps 3, 4 & 6 for passenger side.

8. With assistance, position the Grille Guard on the outside of the frame mounting brackets and lower mounting brackets. Loosely attach the Grille Guard to the frame mounting brackets using the included (6) M12 x 35mm hex bolts, (12) M12 large flat washers, (6) M12 lock washers, and (6) M12 hex nuts. Refer to **Figure 7** for a picture showing the hardware assembly.
9. Loosely attach the Grille Guard to the lower mounting brackets using (4) M12 x 35mm hex bolts, (8) M12 flat washers, (4) M12 lock washers, and (4) M12 hex nuts (**FIG 7**).

Sportsman Grille Guard hardware

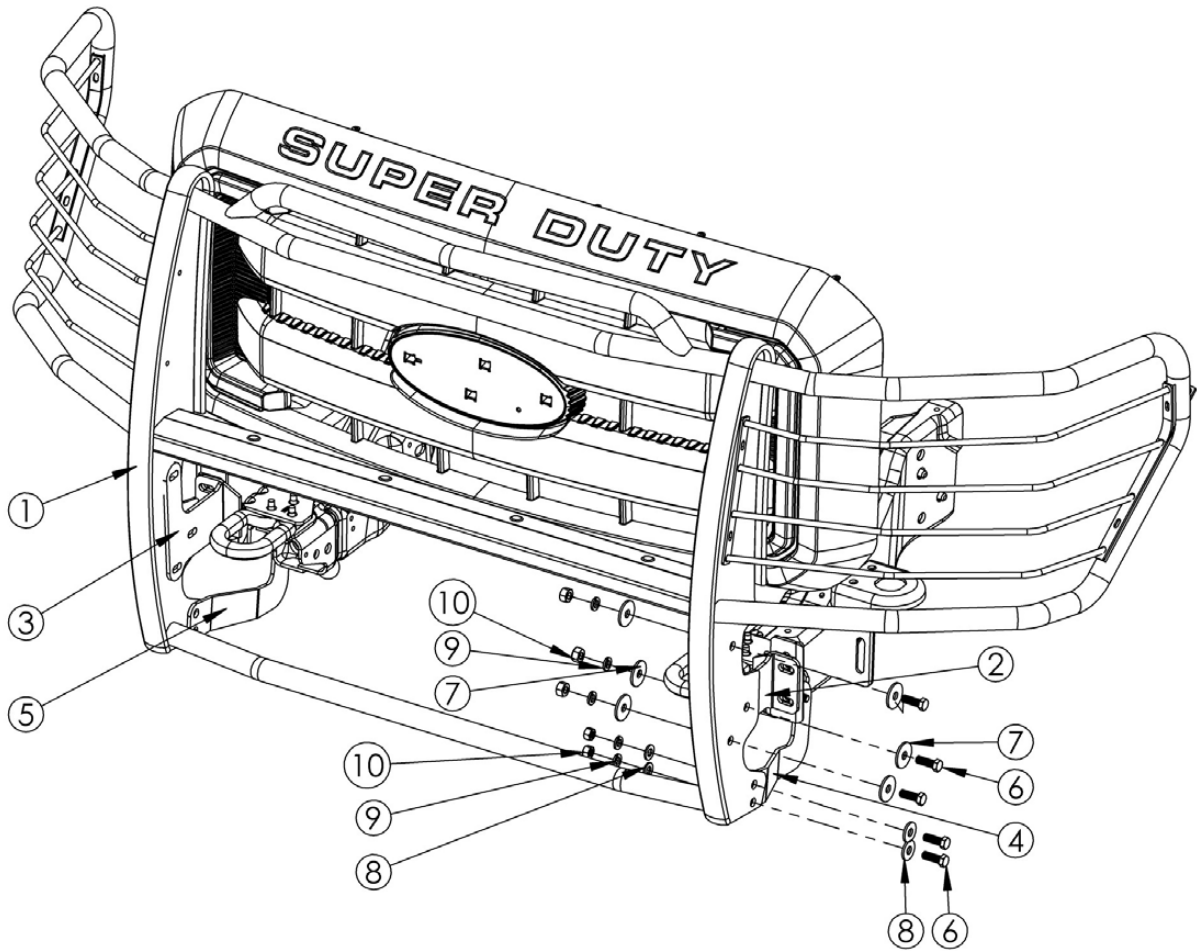
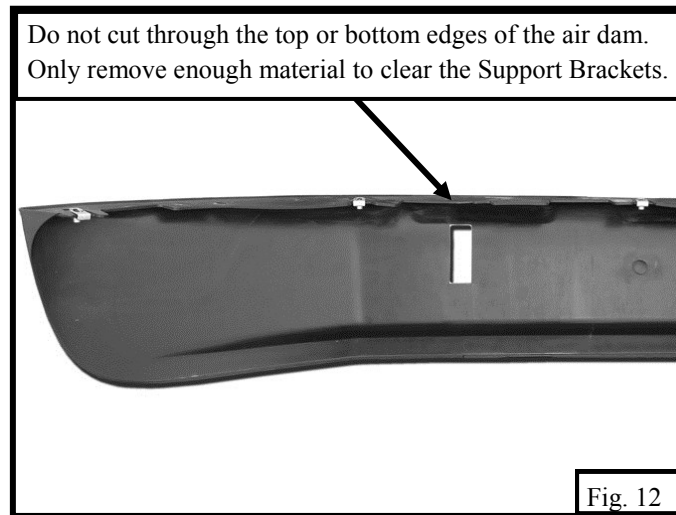
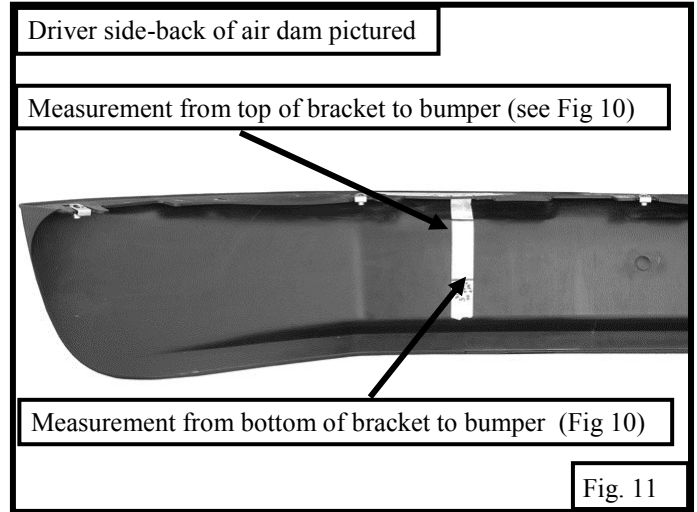
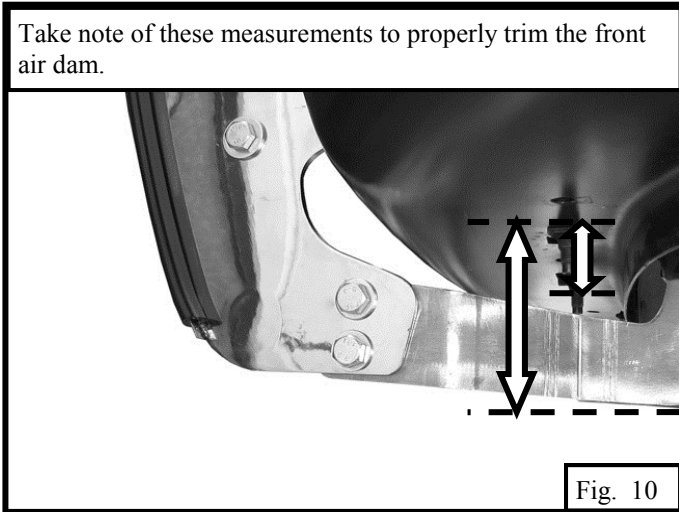
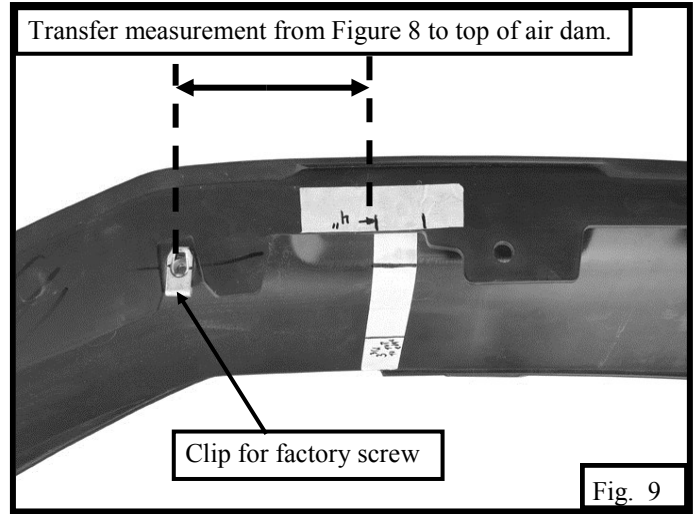
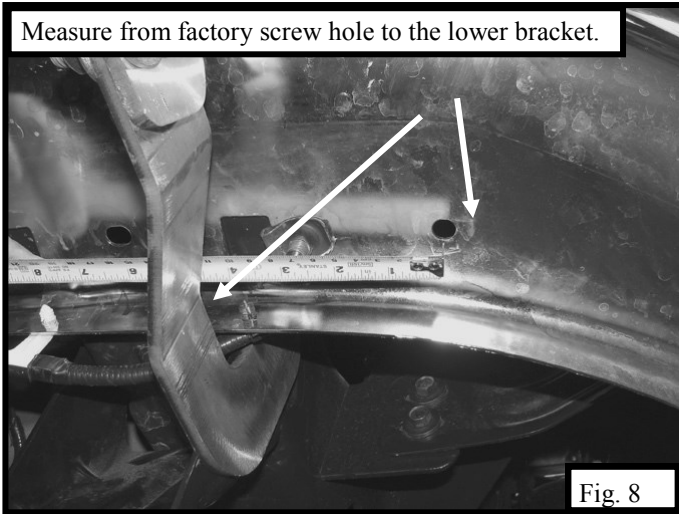

Fig. 7

10. Hold the plastic air dam up in position and mark the location of the lower mounting brackets onto the top of the air dam (**Figures 8– 11**). Measure the location of the mounting brackets and transfer these measurements onto the back of the air dam. (**Figures 8 & 10**). Place the air dam back up to the (2) lower mounting brackets to verify location. Check all measurements on the vehicle. Once absolutely satisfied, use a hacksaw blade or utility knife to carefully cut (2) openings in air dam (**Figure 12**). **NOTE:** Trim as necessary.
11. Re-install air dam over the lower support brackets with the factory hardware. **NOTE:** It will be necessary to loosen or remove the lower mounting brackets to reinstall the air dam.



12. Align and adjust the Grille Guard as necessary, then fully tighten all hardware at this time. Torque all M12 fasteners to 55 ft-lbs.



CARE INSTRUCTIONS

- REGULAR WAXING IS RECOMMENDED. DO NOT USE ANY TYPE OF POLISH OR WAX THAT MAY CONTAIN ABRASIVES.
- STAINLESS STEEL PRODUCTS CAN BE CLEANED WITH MILD SOAP AND WATER. STAINLESS STEEL POLISH SHOULD BE USED TO POLISH SMALL SCRATCHES.
- GLOSS BLACK FINISHES SHOULD BE CLEANED WITH MILD SOAP AND WATER.