



INSTALLATION INSTRUCTIONS

APPLICATION: 2003-07 SILVERADO "CLASSIC" 2500/3500HD 2/4 WHEEL DRIVE
 2003-07 SILVERADO/SIERRA "CLASSIC" 1500HD/2500LD 2/4 WHEEL DRIVE

AUTOMOTIVE PRODUCTS, INC.

SPORTSMAN ASSEMBLY

40-1245
 45-1240
 40-1915
 45-1910

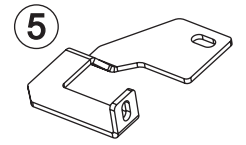
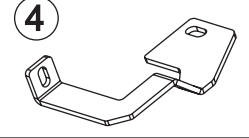
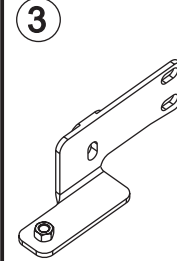
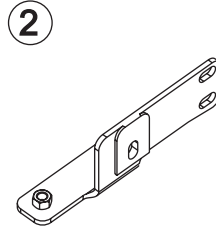
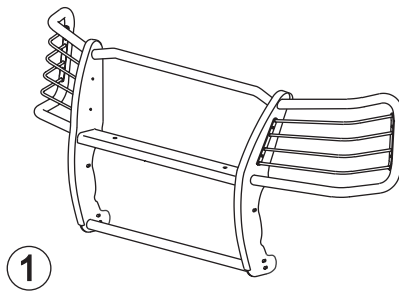

PARTS KIT CONTENTS

ITEM	QTY	DESCRIPTION	ITEM	QTY	DESCRIPTION
1	1	SPORTSMAN ASSEMBLY	11	4	M10 FLAT WASHER, STAINLESS STEEL
2,3	2	BOTTOM BRACKET, PASSENGER(2) AND DRIVER(3)	12	2	M10 LOCK WASHER, STAINLESS STEEL
4,5	2	TOP BRACKET, PASSENGER(4) AND DRIVER(5)	13	2	M10 NUT, STAINLESS STEEL
6	4	M12 X 40MM HEX HEAD BOLT, STAINLESS STEEL	14	4	M12 X 40 HEX HEAD BOLT, YELLOW ZINC
7	8	M12 FLAT WASHER, STAINLESS STEEL	15	6	M12 FLAT WASHER, YELLOW ZINC
8	4	M12 LOCK WASHER, STAINLESS STEEL	16	4	M12 LOCK WASHER, YELLOW ZINC
9	4	M12 NUT, STAINLESS STEEL	17	2	M12 NUT, YELLOW ZINC
10	2	M10 X 35 HEX HEAD BOLT, STAINLESS STEEL	18	2	ANTI-REFLECTIVE TAPE (POLISHED ASSEMBLIES ONLY)

TOOLS REQUIRED

17MM SOCKET	16MM WRENCH	18MM WRENCH	RATCHET EXTENSION
19MM SOCKET	18MM SOCKET	15MM SOCKET	RATCHET

- NOTE: WESTIN ADVISES THE INSTALLER TO USE A THREAD LUBRICANT ON ALL STAINLESS HARDWARE.
- STEP 1. Remove the contents from box and check for damage. Verify all parts are present. Read instructions completely before beginning.
- STEP 2. Remove the tow hooks from the vehicle. If the vehicle did not come with the factory tow hooks it is necessary to cut out the area of the lower valance where the hooks would have been. Position the lower driver bracket in the frame. Loosely attach the lower bracket to the frame using two yellow zinc M12 x 40 bolts, one nut, three flat washers, and two lock washers. **SEE FIGURE 1.** Repeat for passenger side.
- STEP 3. From the front of vehicle, locate the top bumper mounting bolt. This can be seen by looking through the bumper cut outs in the front of the bumper opening. Use factory bumper bolt to secure bracket. **SEE FIGURE 2.** Leave loose. Repeat for opposite side.
- STEP 4. Place Sportsman up to vehicle and secure lower brackets to Sportsman uprights using stainless steel M12 x 40 hex head bolts, M12 nuts, M12 flat washers, and M12 lock washers. Secure upper brackets to sportsman using M10 x 35 hex head bolts, M10 nuts, M10 flat washers, and M10 lock washers. **SEE FIGURE 2.** Level and adjust Sportsman. Tighten all fasteners.
- STEP 5. If light glare is being experienced off the wings of the grille guard, anti reflective tape has been supplied to reduce glare. With headlights on, note where the reflection is concentrated on the wing. Clean the wing well with a non-abrasive cleaner (rubbing alcohol works the best.) Trim the anti-reflective tape to the appropriate size where the glare was located and apply tape. **SEE FIGURE 3.**

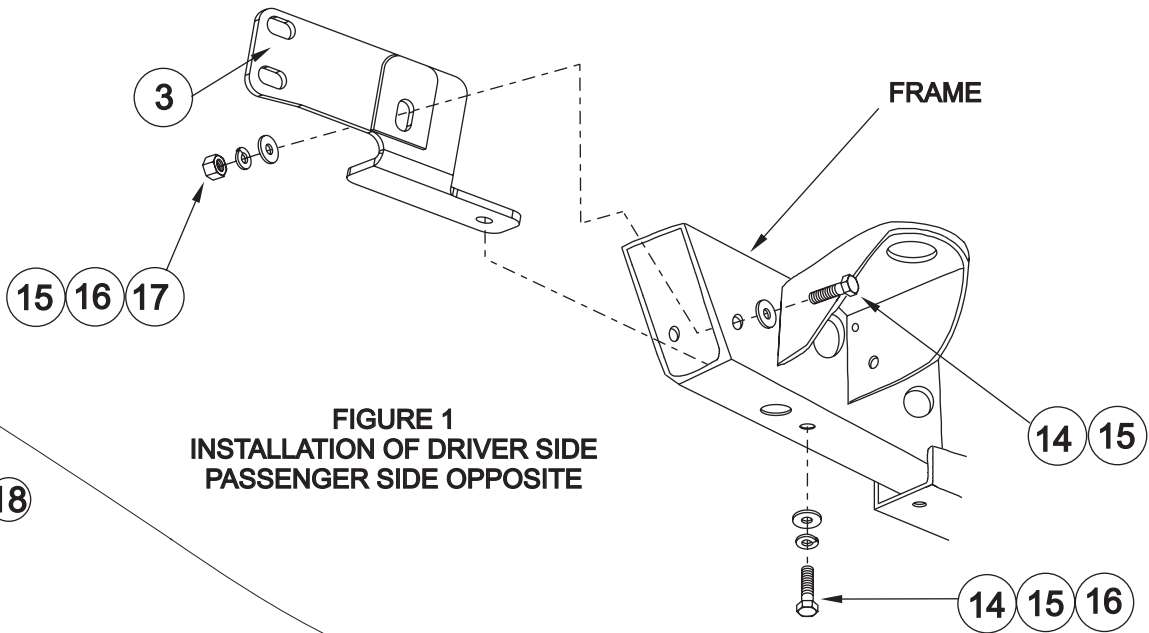

**FIGURE 1
INSTALLATION OF DRIVER SIDE
PASSENGER SIDE OPPOSITE**

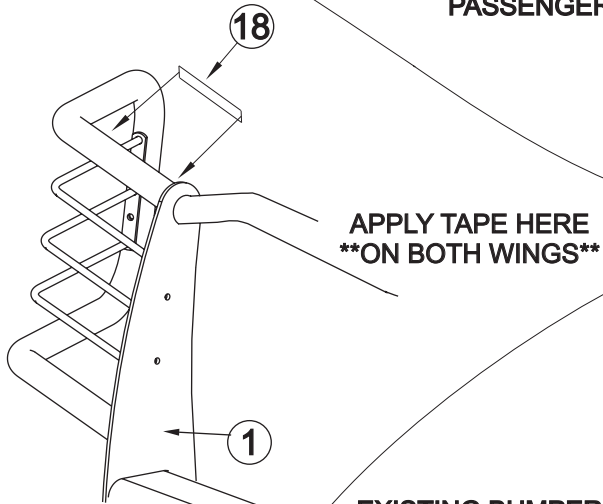
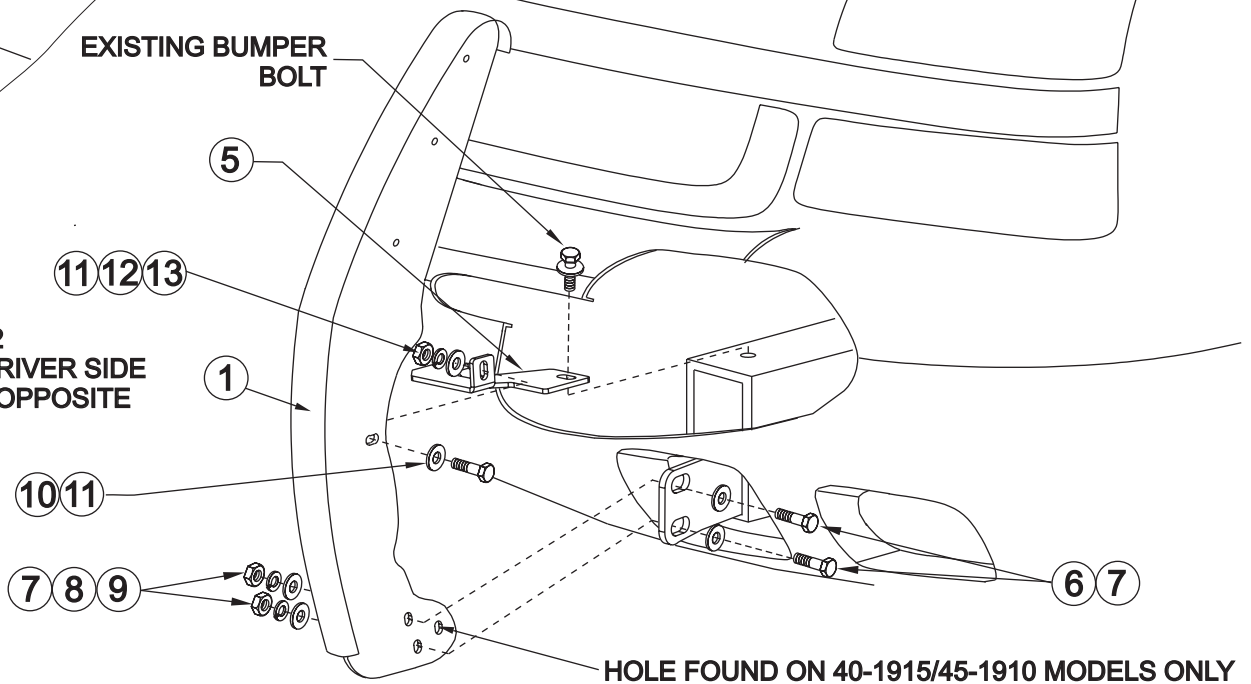

FIGURE 3

EXISTING BUMPER
BOLT

**FIGURE 2
INSTALLATION OF DRIVER SIDE
PASSENGER SIDE OPPOSITE**



Finish protection - Westin products have a high quality finish that must be cared for like any other exposed finish on the vehicle. Protect the finish with a non-abrasive automotive wax (pure carnauba, for example) on a regular basis. The use of cleaner wax or any compound which contains an abrasive is detrimental, as the compounds scratch the finish and open it to corrosion.