

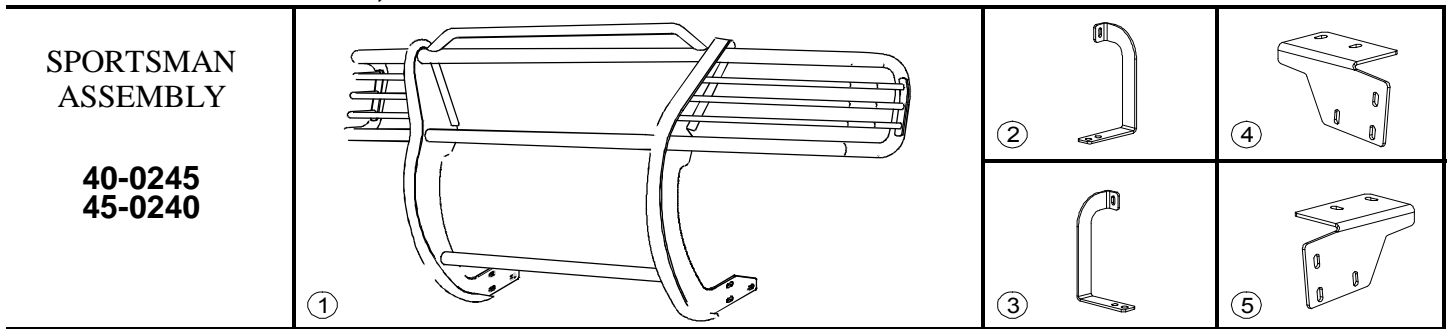

# INSTALLATION INSTRUCTIONS

APPLICATION: 1997-04 FORD F-150/250 LIGHT DUTY(HERITAGE)  
1997-02 FORD EXPEDITION  
4 WHEEL DRIVE

AUTOMOTIVE PRODUCTS, INC.



## PARTS KIT CONTENTS

ITEM	QTY	DESCRIPTION	ITEM	QTY	DESCRIPTION
1	1	SPORTSMAN ASSEMBLY	10	2	M10 X 35MM HEX HEAD BOLT
2,3	2	TOP BRACKET, PASSENGER(2) AND DRIVER(3)	11	4	M10 FLAT WASHER
4,5	2	BOTTOM BRACKET, PASSENGER(4) AND DRIVER(5)	12	2	M10 LOCK WASHER
6	6	M12 X 40MM HEX HEAD BOLT, STAINLESS STEEL	13	2	M10 HEX NUT
7	12	M12 FLAT WASHER, STAINLESS STEEL	14	2	M12 X 1.75 HEX FLANGE NUT
8	6	M12 LOCK WASHER, STAINLESS STEEL	15	2	ANTI-REFLECTIVE TAPE (FOR POLISHED ASSEMBLIES ONLY.)
9	6	M12 HEX NUT, STAINLESS STEEL			

## TOOLS REQUIRED

17MM SOCKET	18MM WRENCH	18MM SOCKET	16MM WRENCH
19MM SOCKET	15MM SOCKET	RATCHET	TORQUE WRENCH

- NOTE:** WESTIN ADVISES THE INSTALLER TO USE A THREAD LUBRICANT ON ALL STAINLESS HARDWARE.
- STEP 1. Remove the contents from box and check for damage. Verify all parts are present. Read instructions completely before beginning.
- STEP 2. Remove tow hook by removing bolt 2 and loosening bolt 1. Slide tow hook toward rear and remove. **SEE FIGURE 1.**
- STEP 3. Remove bolt 1, making sure the nut plate inside frame stays aligned with the frame hole for bolt 1.
- STEP 4. Hang bottom bracket in position by partially threading bolt 1 (without the tow hook) into nut plate.
- STEP 5. Align the nut plate by rotating bolt 1 back and forth so that bolt 2 can be inserted.
- STEP 6. Position the tow hook in place by hanging it by the slotted end first, then insert bolt 2.
- STEP 7. Tighten mount bolts so that bottom bracket is loose.
- STEP 8. Follow step 3 through 8 to install the opposite side bottom bracket.
- STEP 9. From inside of frame behind bumper, position top bracket so that front of bracket protrudes between top of bumper and bottom of grille. Push down on bumper cover to slide bracket through. Locate bumper bolt ends (front side of frame), then position hole of bracket on the end of the top bolt, over existing nut. Hand tighten supplied 12mm flange nut over bracket. Repeat for other side. **SEE FIGURE 1.**
- NOTE:** 1997-98 models use lower hole on bracket.  
1999-01 models use upper hole on bracket.
- STEP 10. Place cardboard under front of vehicle. Lay Sportsman on cardboard with front side down.
- STEP 11. Slide unit back so that the rearmost slots align with the rearmost slots on the brackets. Fasten together the rear slots on both sides as shown. Hand tighten
- STEP 12. Rotate Sportsman up toward vehicle until remaining slots are aligned. Fasten bottom with remaining 12mm fasteners. Attach to top brackets using 10mm fasteners as shown. **SEE FIGURE 1.**

STEP 13. Center and level Sportsman. Tighten all fasteners.

STEP 14. For polished assemblies. If light glare is being experienced off the wings of the grille guard, anti reflective tape has been supplied to reduce glare. With headlights on, note where the reflection is concentrated on the wing. Clean the wing well with a non-abrasive cleaner (rubbing alcohol works the best.) Trim the anti-reflective tape to the appropriate size where the glare was located and apply tape. **SEE FIGURE 2.**

---

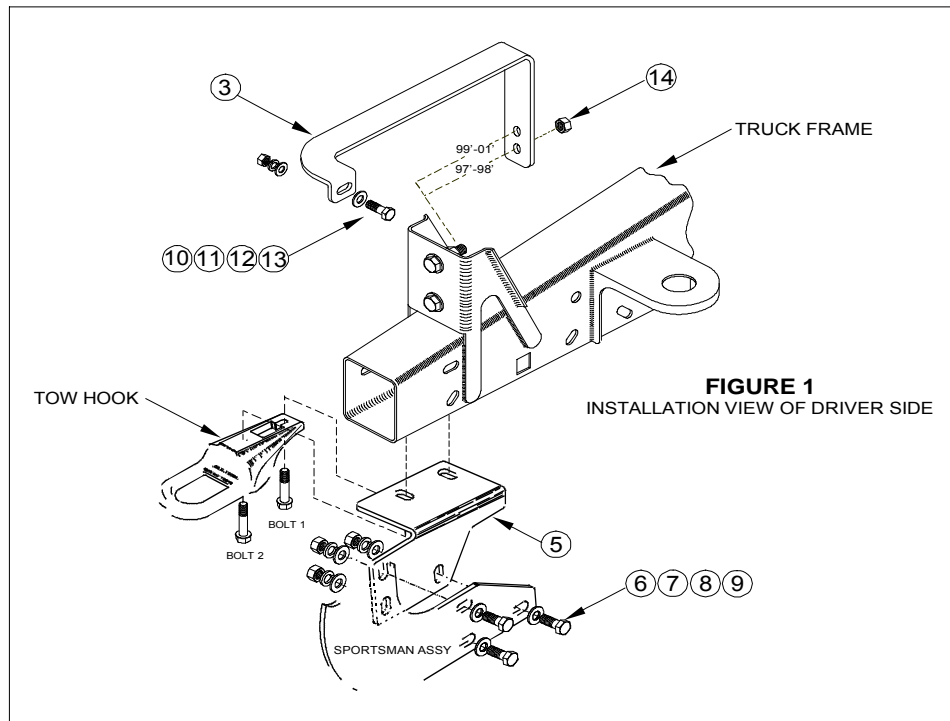
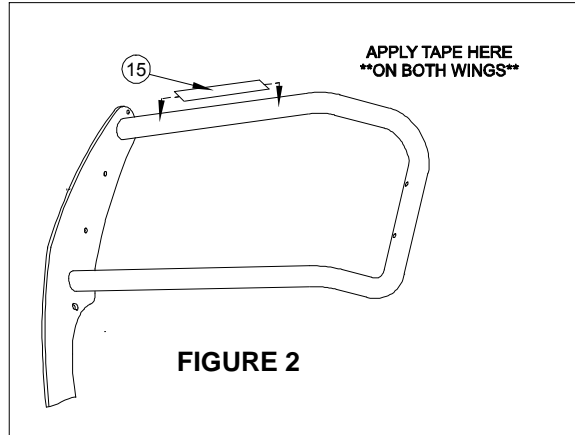

---

Finish protection - Westin products have a high quality finish that must be cared for like any other exposed finish on the vehicle. Protect the finish with a non-abrasive automotive wax (pure carnauba, for example) on a regular basis. The use of cleaner wax or any compound which contains an abrasive is detrimental, as the compounds scratch the finish and open it to corrosion.

---