



INSTALLATION INSTRUCTIONS

ULTIMATE BULL BAR

APPLICATION:

2017 Ford F-250/350

PART NUMBER:

32-3900, 32-3905, 32-3900L, 32-3905L

AUTOMOTIVE PRODUCTS, INC.

ITEM	QUANTITY	DESCRIPTION	TOOLS NEEDED
1	1	ULTIMATE BULL BAR ASSEMBLY	18MM SOCKET
2	1	DRIVER SIDE MOUNT BRACKET	18MM WRENCH
3	1	PASSENGER SIDE MOUNT BRACKET	9/16" SOCKET
4	4	3/8-16 X 1.00" BUTTON HEAD SOCKET CAP SCREW	13MM & 9/16" WRENCH
5	4	3/8" FLAT WASHER	7/32" ALLEN KEY
6	4	3/8" SPLIT LOCK WASHER	RATCHET
7	4	3/8-16 HEX NUT	TORQUE WRENCH
8	1	LED WIRING HARNESS (09-12000-1)	FLATHEAD SCREW-DRIVER

ANTI-SEIZE LUBRICANT MUST BE USED ON ALL STAINLESS STEEL FASTENERS TO PREVENT THREAD DAMAGE AND GALLING

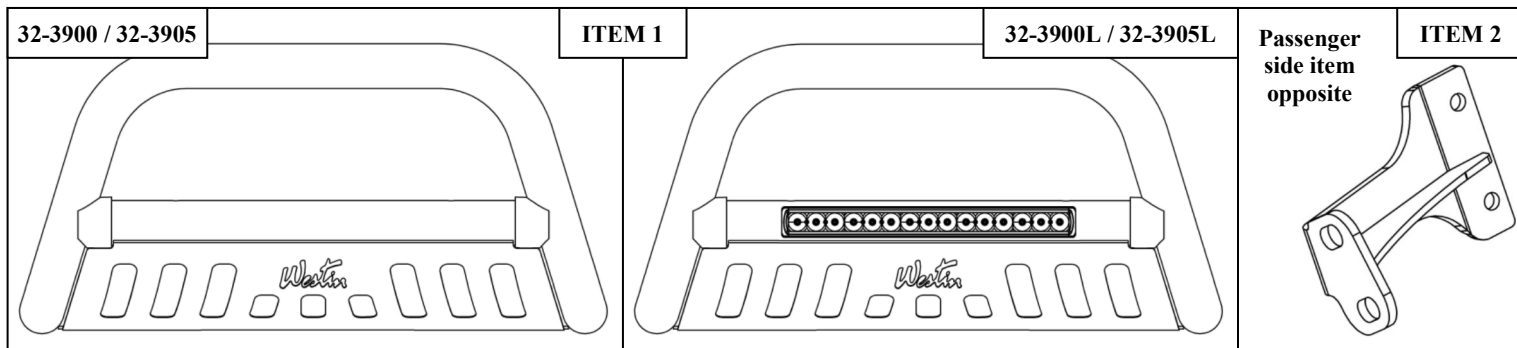

PROCEDURE

1. Remove contents from box, verify if all parts listed are present and free from damage. Carefully read and understand all instructions before attempting installation.
Failure to identify damage before installation could lead to a rejection of any claim.
2. Starting on either side, use a flathead screw driver to remove the plastic covers located around the factory tow hooks. Repeat for other side. See **Figures 1 and 2.**



Figure 1



Figure 2



3. Removing the plastic covers exposes factory hardware. See **Figure 3**.
4. Starting at either side. Locate (1) mount bracket (Item 2/3) and loosely secure onto mount location using the factory hardware present. See **Figure 4**.

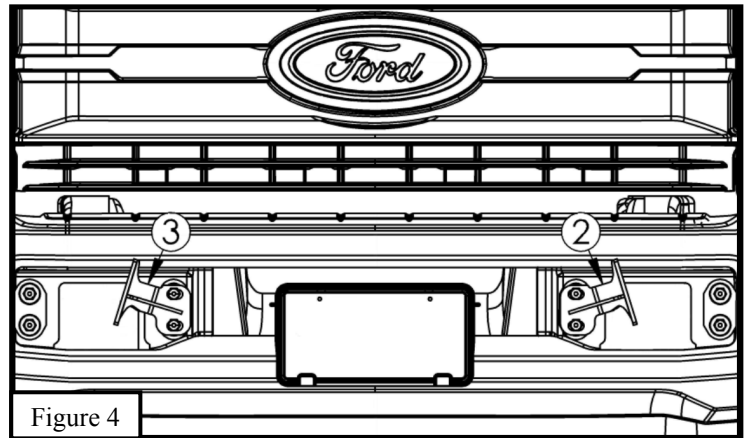

5. Align the plastic cover that was previously removed and trimming may be necessary, on the side that the mount bracket was installed, to be able to reattach to vehicle. See **Figure 5**.
6. Repeat **Steps 4 - 5** for other side.
7. Locate the ultimate bull bar assembly (Item 1) and with assistance align it with the previously installed brackets and loosely secure using the provided hardware (Items 4 - 7). See **Figure 6**.
8. Align and adjust the ultimate bull bar assembly and mount brackets as necessary then tighten: factory hardware to 72 ft-lbs and 3/8 hardware to 22 ft-lbs.
9. **For part number 32-3905L:** Refer to **Page 4** for wiring instructions. Loosen M8 hardware to adjust the LED light in bull bar or to remove it in order to replace it. See **Figure 7** for location of M8 hardware.

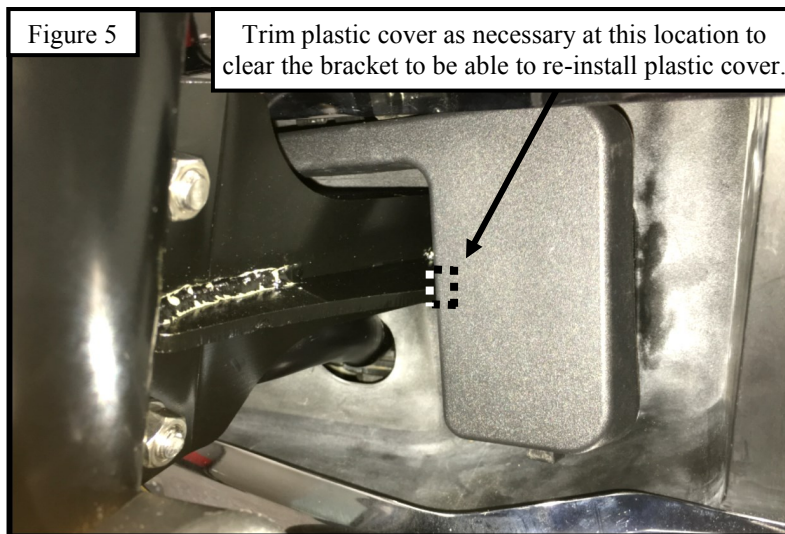

CARE INSTRUCTIONS

- REGULAR WAXING IS RECOMMENDED. DO NOT USE ANY TYPE OF POLISH OR WAX THAT MAY CONTAIN ABRASIVES.
- STAINLESS STEEL PRODUCTS CAN BE CLEANED WITH MILD SOAP AND WATER. STAINLESS STEEL POLISH SHOULD BE USED TO POLISH SMALL SCRATCHES.
- GLOSS BLACK FINISHES SHOULD BE CLEANED WITH MILD SOAP AND WATER.



Figure 6

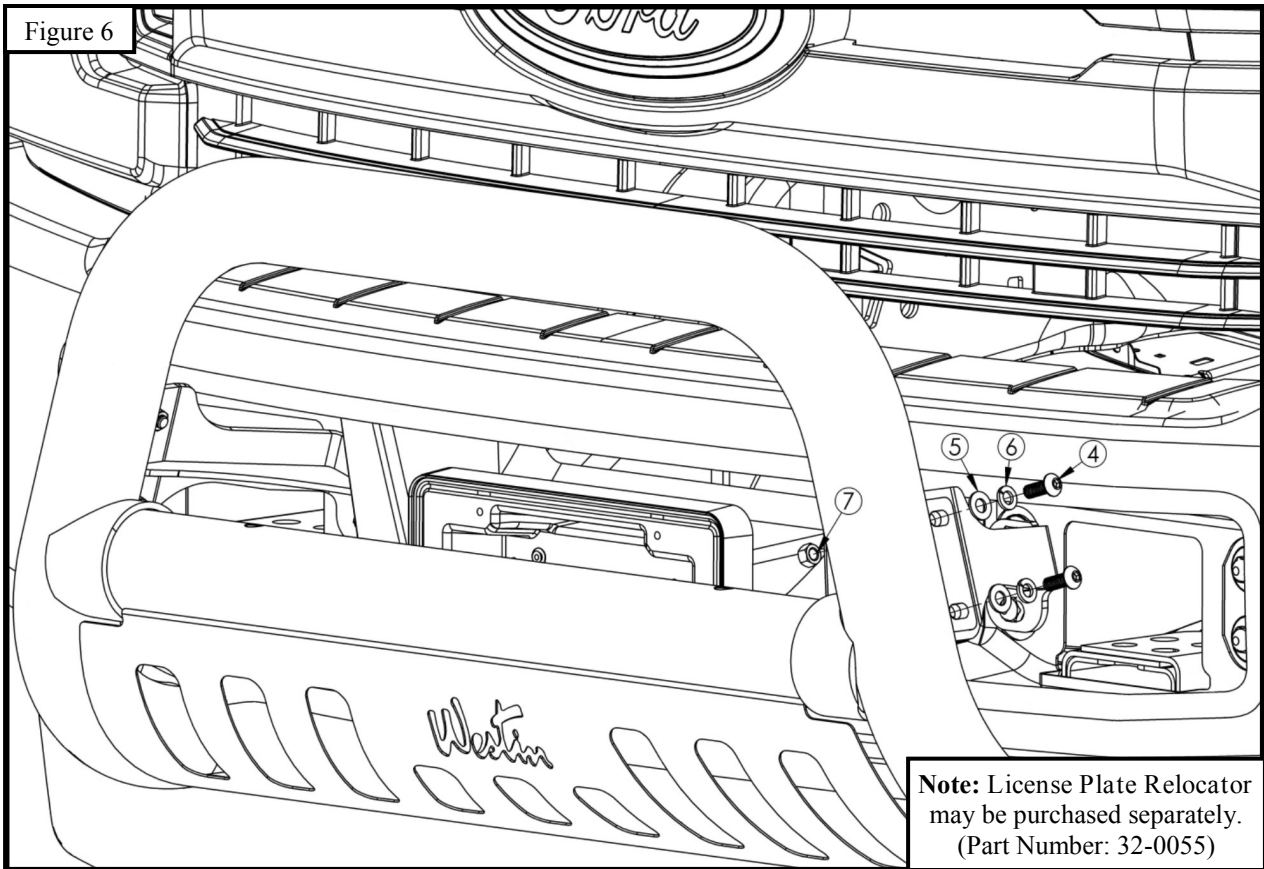

Note: License Plate Relocator may be purchased separately. (Part Number: 32-0055)

INSTALLATION COMPLETE



Westin.
SIGNATURE OF QUALITY

WIRING INSTRUCTIONS 32-3905L:

WESTIN recommends using a professional for this installation.

CAUTION:

1. Disconnect ground connection from battery (-) to avoid accidental short circuits before attempting to connect electrical wires.
2. When running wires, avoid areas of excessive heat, vibration, pinch or rotation when securing harness to vehicle.
3. Always use a fused (+) positive supply source.
4. This light becomes hot under continuous use. Do not remove or touch the casting for at least 30 minutes after the lamp has been turned off.

Refer to Figure 8.

1. Locate wiring harness and mount the switch in a convenient location where it is easily accessible from the drivers seat.
Note: *The switch will need to be removed from the wiring harness so that the rest of the harness can be routed from the engine bay to the cabin.*
2. Route the wiring harness wire, specifically the fuse and relay, from the positive battery terminal along the firewalls existing wire routes. **Note:** *Tape as necessary to correct slack.*
3. Secure the relay by either drilling or using a pre-existing bolt along the chassis that is not connected to any other wire.
4. Run the switch harness through the firewall preferably through the pre-existing rubber plug that is used to run the OEM wiring harness from the engine bay to fuse box. **Note:** *Reconnect the switch to the wiring harness.*
5. Place the LED plug wire along the fender chassis where it will not get pinched and away from any moving parts (fan, pulleys etc.).
6. Run the attached wire from the LED Light Bar as previously mentioned away from any moving parts.
7. Connect both ends of wiring connectors from LED light bar and wiring harness.
8. Re-connect battery terminals, attach the Red (+) wire to battery positive, and the black (-) wire to ground. **Note:** *Add dielectric grease (not supplied).*
9. Turn on the switch to make sure if the lamp works. If not, please check carefully if the wiring installation is correct.

M8 hardware attaches LED light onto bull bar.

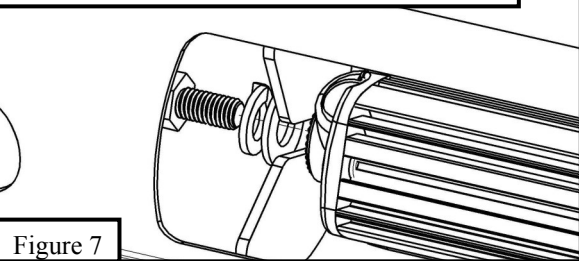

Figure 7

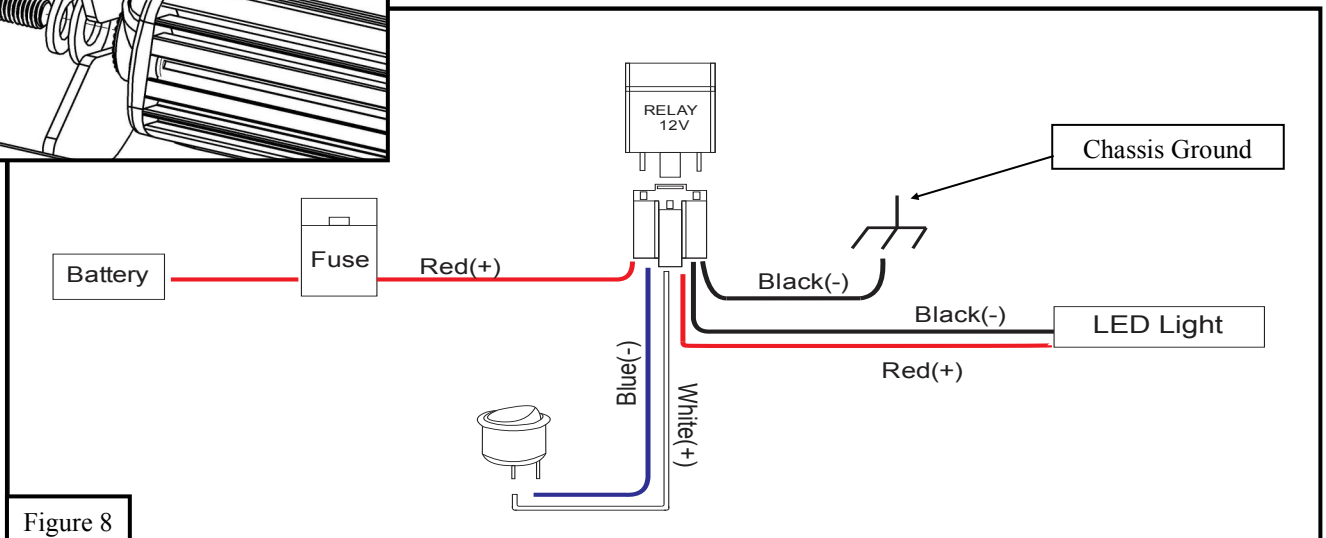

Figure 8

Westin

SIGNATURE OF QUALITY

AUTOMOTIVE PRODUCTS, INC.



WARNING



Failure to follow these instructions could lead to death, personal injury, and / or property damage.

FASTENERS:

All Westin supplied fasteners must be utilized and installed in accordance with the installation instructions and apply torque to the specifications as defined. **DOUBLE CHECK ALL FASTENERS BEFORE INITIAL USE, AND PERIODICALLY IN THE FUTURE TO ENSURE PROPER FUNCTION AND SAFETY.**

DRILLING:

Most Westin products do not require drilling for installation. If drilling is defined as required, use caution when drilling a vehicle. **FAILURE TO REVIEW AN AREA TO BE DRILLED MAY RESULT IN PERSONAL INJURY AND/OR INJURY TO OTHERS AS WELL AS VEHICLE DAMAGE.**

EYE PROTECTION:

ALWAYS WEAR SAFETY GLASSES OR GOGGLES DURING THE INSTALLATION PROCESS TO AVOID PERSONAL INJURY.

MAXIMUM TOWING/CARRYING CAPACITY:

The Westin Receiver Hitches will have a visible tow rating label affixed directly on the product. User should never exceed the vehicle manufacturers maximum tow and weight rating regardless of the capacity of the hitch. **FAILURE TO FOLLOW THESE GUIDELINES WILL VOID THE WESTIN WARRANTY AND MAY RESULT IN PERSONAL INJURY AND/OR INJURY TO OTHERS AS WELL AS VEHICLE DAMAGE.**

Westin.
SIGNATURE OF QUALITY