



SIGNATURE OF QUALITY

AUTOMOTIVE PRODUCTS, INC.

INSTRUCTIONS

APPLICATION: 2011-14 JEEP GRAND CHEROKEE
2011-13 DODGE DURANGO
PART # 32-3580, 32-3585
ULTIMATE BULL BAR

ITEM	QUANTITY	DESCRIPTION	TOOLS NEEDED
1	1	BULL BAR	17MM SOCKET
2,3	2	MOUNTING BRACKET 2(DRIVERS SIDE), 3(PASSENGER SIDE)	17MM WRENCH
4	4	M10 HEX HEAD BOLTS (YELLOW ZINC)	TORQUE WRENCH
5	4	M10 FLAT WASHERS (YELLOW ZINC)	ALLEN WRENCH
6	4	M10 LOCK WASHERS (YELLOW ZINC)	9/16" WRENCH
7	4	3/8 BUTTON HEAD BOLTS (STAINLESS STEEL)	FLAT HEAD SCREWDRIVER
8	8	3/8 FLAT WASHERS (STAINLESS STEEL)	
9	4	3/8 LOCK WASHERS (STAINLESS STEEL)	
10	4	3/8 HEX NUTS (STAINLESS STEEL)	

IMPORTANT: This Bull Bar is not compatible with optional Adaptive Cruise Control-Forward Collision Warning Systems.
Anti-seize thread lubricant must be used on all stainless steel fasteners to prevent galling.

1. Remove all contents from box, verify all parts listed are present and free from damage. Carefully read and understand all instructions before attempting installation.
2. Determine if the vehicle is equipped with or without factory tow hooks, (Figure 1). Remove the plastic splash guard, (Figure 2). If vehicle is equipped with tow hooks, remove both tow hooks and proceed to Step 5. NOTE: Tow hooks cannot be reinstalled with the Bull Bar.
3. **2011 - 13 vehicles without factory tow hooks:** Release the clips at the ends of the plastic bumper cover that attach the lower cover to the upper cover, (Figure 3). NOTE: It is not necessary to remove the lower cover, only release the clips at the ends of the cover. Next, remove the (3) clips fastening the air deflector to the bottom of the cross member, (Figure 4). Pull the bumper cover forward for access and pull the air deflector out from behind the bumper cover, (Figure 5). Release the clips securing the (2) block off covers to the ends of the air deflector, (Figure 8). Remove the (2) block offs. Reinstall the air deflector using the factory hardware. Reinstall the bumper cover. TO REMOVE THE AIR DAM ON THE DODGE DURANGO REFER TO FIGURES 6 AND 7.
4. **2014 Grand Cherokee without factory tow hooks:** Carefully pry on the tow hook pocket covers to pop them loose. They will not be re-used (Figure 9)
5. Select the driver side Frame Mounting Bracket. Line up the (2) slots in the bracket with the (2) threaded holes in the bottom of the frame channel, (Figure 10). Loosely attach the Bracket to the frame channel with (2) M10 Hex Bolts (yellow zinc), (2) M10 Flat Washers (yellow zinc) and (2) M10 Lock Washers (yellow zinc). Repeat this step for the passenger side Frame Bracket installation.
6. With assistance, hold the Bull Bar up to the outside of the Mounting Brackets. Attach the Bull Bar to the Mounting Brackets with the included (4) 3/8 Button Head Bolts (stainless steel), (8) 3/8 Flat Washers (stainless steel), (4) 3/8 Lock Washers (stainless steel) and (4) 3/8 Hex Nuts (stainless steel), (Figure 11).
7. Align and adjust the Bull Bar and tighten all hardware. Reinstall the splash guard removed in Step 2.
8. Torque all M10 fasteners to 35-40 ft lbs, and 3/8" fasteners to 25-30 ft lbs.

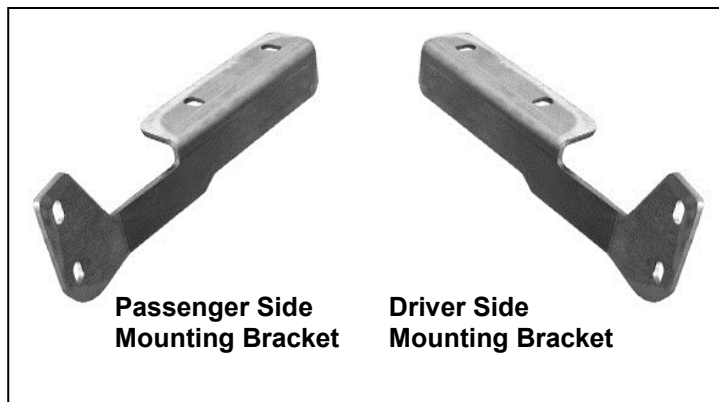

Thank You for choosing Westin products.

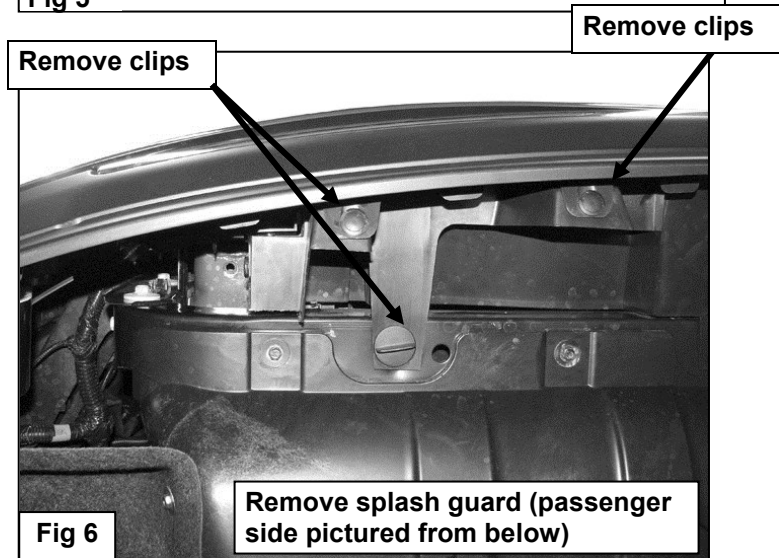
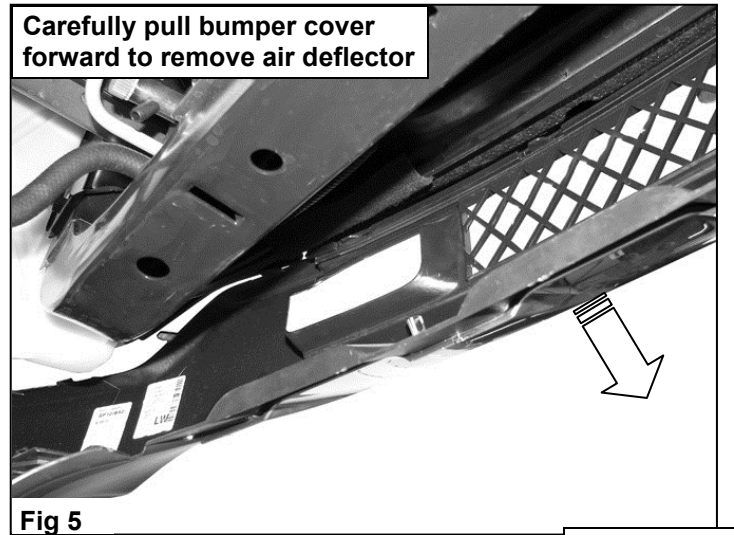
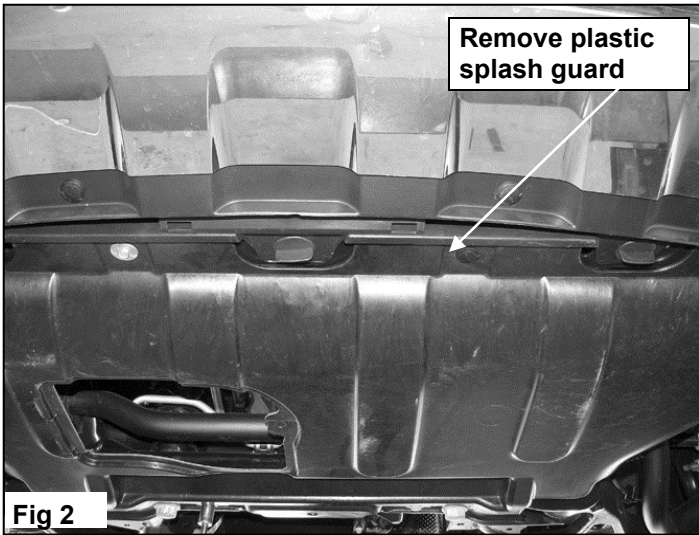
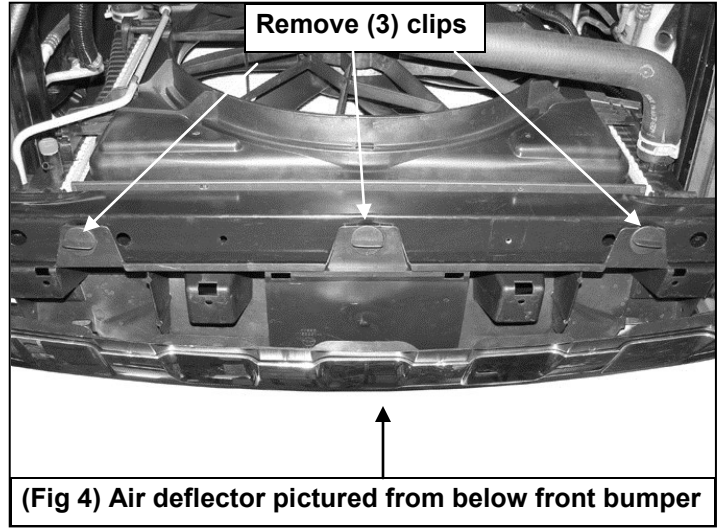
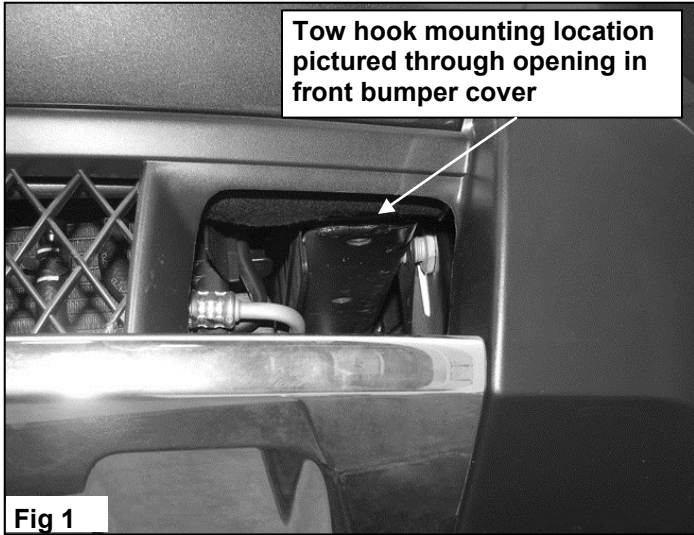

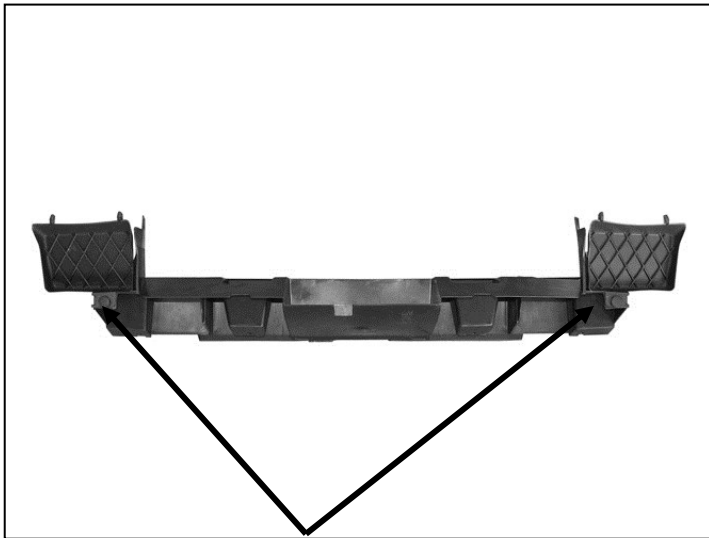
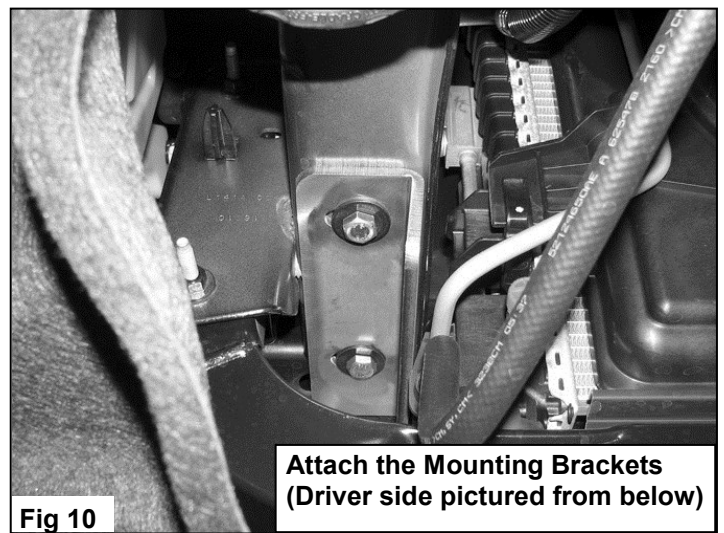
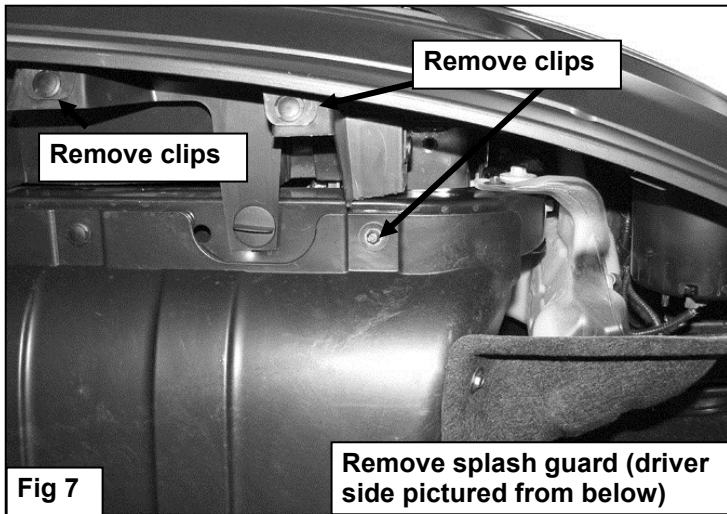

INSTALLATION COMPLETE



CARE INSTRUCTIONS:

- REGULAR WAXING IS RECOMMENDED. DO NOT USE ANY TYPE OF POLISH OR WAX THAT MAY CONTAIN ABRASIVES.
- STAINLESS STEEL PRODUCTS CAN BE CLEANED WITH MILD SOAP AND WATER. STAINLESS STEEL POLISH SHOULD BE USED TO POLISH SMALL SCRATCHES.
- GLOSS BLACK FINISHES SHOULD BE CLEANED WITH MILD SOAP AND WATER.



Thank You for choosing Westin products.