

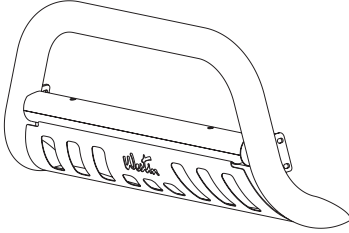
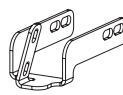
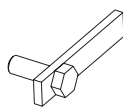
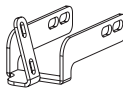

INSTRUCTIONS

APPLICATION: 2007-08 CHEVY SILVERADO/ GMC SIERRA 1500 SERIES

AUTOMOTIVE PRODUCTS, INC.

| BULL BAR ASSEMBLY 32-2270 32-2275 | |  |  |  |
|---|-----|---|---|---|
| | | |  | |
| ITEM | QTY | CONTENTS | TOOLS | |
| 1 | 1 | BULL BAR ASSEMBLY | 3/4" SOCKET 3/4" WRENCH 9/16" SOCKET 9/16" WRENCH 18MM SOCKET 18MM WRENCH RATCHET SOCKET EXTENSION TORQUE WRENCH UTILITY KNIFE | |
| 2,3 | 2 | BRACKET, PASSENGER (2) AND DRIVER (3) | | |
| 4 | 2 | PLASTIC PLUG | | |
| 5 | 4 | RUBBER BUMPER | | |
| 6 | 6 | BOLT PLATE | | |
| 7 | 6 | 1/2" FLAT WASHER | | |
| 8 | 6 | 1/2" LOCK WASHER | | |
| 9 | 6 | 1/2-13 HEX NUT | | |
| 10 | 4 | 3/8-16 X 1.25" HEX HEAD BOLT, STAINLESS STEEL | | |
| 11 | 8 | 3/8" FLAT WASHER, STAINLESS STEEL | | |
| 12 | 4 | 3/8" LOCK WASHER, STAINLESS STEEL | | |
| 13 | 4 | 3/8-16 HEX NUT, STAINLESS STEEL | | |

- STEP 1.** Remove the contents from box and check for damage. Verify all parts are present. Read instructions completely before beginning. **NOTE:** Westin advises the installer to use a thread lubricant on all of the stainless steel fasteners.
- STEP 2.** **NOTE:** It may be necessary to remove the front license plate and bracket. Remove license plate from bracket. Using a 3/16" drill bit, drill out the two pop rivets that hold the bracket to the bumper. If local/state laws requires a license plate, license plate relocation kit 32-0055 is available.
- STEP 3.** Remove tow hooks by removing the front bolt and rear bolt that threads into the side of the tow hooks. Tow hooks will not be reinstalled.
- STEP 4.** Determine passenger and driver side brackets. Slide bracket in through the tow hook pocket. Align slots on bracket with holes on frame. Slide the three bolt plates inside the frame and out through aligned holes on both sides of the frame. Secure with 1/2" yellow zinc fasteners. Leave loose. **SEE FIGURE 2.**
NOTE: Minor trimming of tow hook area may be needed. It may be necessary to clean out mounting holes on frame. **SEE FIGURE 2.**
- STEP 5.** Attach Bull Bar to mount brackets using 3/8" stainless steel fasteners. Level and adjust Bull Bar as desired and tighten all fasteners. Recommended torque values are 64 Ft. Lbs. for 1/2" yellow zinc fasteners and 17 Ft. Lbs. for 3/8" stainless steel fasteners. **SEE FIGURE 2.**

LIGHT INSTALLATION: Insert threaded stud on base of the light through hole in cross tube. Using a ratchet, extension and socket for correct size of nut supplied, insert through large clearance hole in bottom of cross tube. Thread nut and washers on stud and tighten. **SEE FIGURE 1.** **NOTE:** A short socket, not a deep well works best to get the nut started.

NOTE: Fits most 6" round or rectangle lights. Some lights may require replacing included mount/isolator with rubber bumpers provided. Mounting stud of 1/2" or less required. Plug mount holes with caps provided if not installing lights.

FINISH PROTECTION

Westin products have a high quality finish that must be cared for like any other exposed finish on the vehicle. Protect the finish with a non-abrasive automotive wax, (e.g. Pure Carnauba) on a regular basis. The use of any soap, polish or wax that contains an abrasive is detrimental, as the compounds scratch the finish and open it to corrosion.

