



AUTOMOTIVE PRODUCTS,

# INSTALLATION INSTRUCTIONS

## ULTIMATE BULL BAR

### APPLICATION:

2009-2018 Dodge Ram 1500 (Excl. Rebel Model)

2019 Dodge Ram 1500 Classic

### PART NUMBER:

32-1960, 32-1965, 32-1960L, 32-1965L

ITEM	QUANTITY	DESCRIPTION	TOOLS NEEDED
1	1	ULTIMATE BULL BAR	18MM SOCKET
2	2	UPPER FRAME MOUNT BRACKET	17MM SOCKET
3,4	2	LOWER MOUNT BRACKET, DRIVER (3) AND PASSENGER (4)	18MM WRENCH
5,6	2	SUPPORT BRACKET, DRIVER (5) AND PASSENGER (6)	17MM WRENCH
7	6	M12 HEX HEAD BOLT (YELLOW ZINC) FINE THREAD	10MM WRENCH
8	4	M12 HEX BOLTS (STAINLESS STEEL) COARSE THREAD	4MM HEX KEY
9	18	M12 FLAT WASHERS, (8) STAINLESS STEEL, (10) YELLOW ZINC	19MM SOCKET
10	10	M12 LOCK WASHERS, (4) STAINLESS STEEL, (6) YELLOW ZINC	19MM WRENCH
11	8	M12 HEX NUTS, (4) STAINLESS STEEL, (4) YELLOW ZINC	RATCHET
12	2	M10 HEX BOLTS (YELLOW ZINC)	TORQUE WRENCH
13	2	M10 LOCK WASHERS (YELLOW ZINC)	
14	4	M10 FLAT WASHERS (YELLOW ZINC)	
15	2	M10 HEX NUTS (YELLOW ZINC)	
16	2	M6 HEX SOCKET BUTTON HEAD SCREWS (STAINLESS STEEL)	
17	4	M6 FLAT WASHERS (STAINLESS STEEL)	
18	2	M6 NYLON INSERT HEX NUTS (STAINLESS STEEL)	
19	1	LED WIRING HARNESS (09-12000-1)	

**ANTI-SEIZE LUBRICANT MUST BE USED ON ALL STAINLESS STEEL FASTENERS TO PREVENT THREAD DAMAGE AND GALLING**

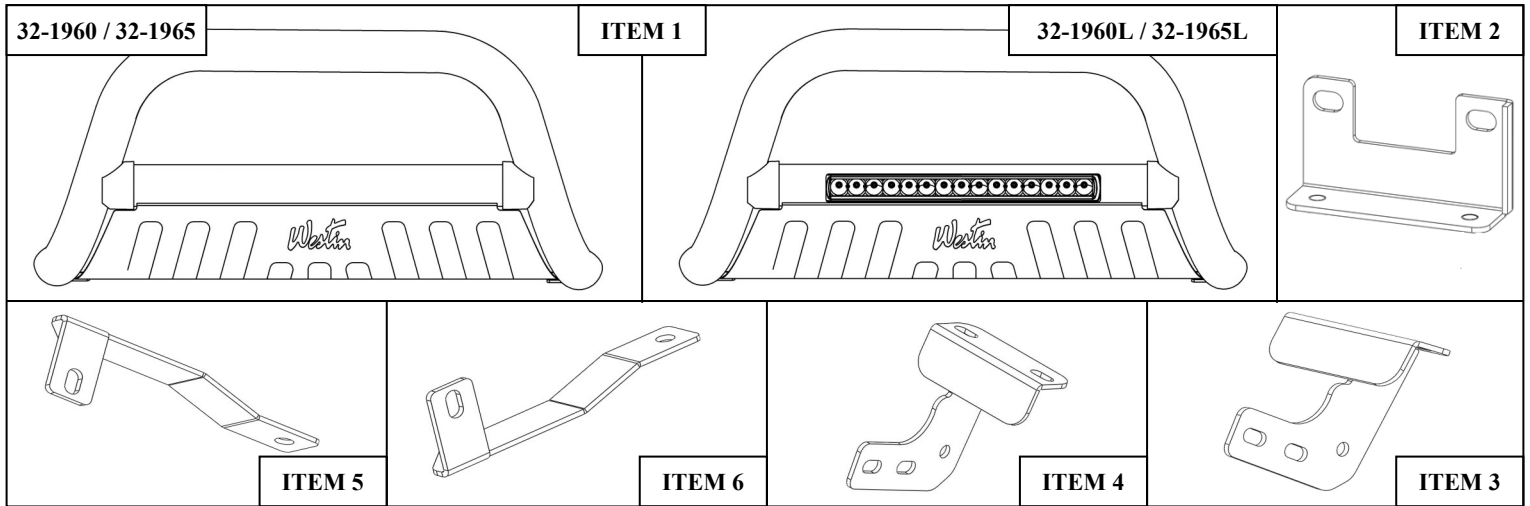

### CARE INSTRUCTIONS

- REGULAR WAXING IS RECOMMENDED. DO NOT USE ANY TYPE OF POLISH OR WAX THAT MAY CONTAIN ABRASIVES.
- STAINLESS STEEL PRODUCTS CAN BE CLEANED WITH MILD SOAP AND WATER. STAINLESS STEEL POLISH SHOULD BE USED TO POLISH SMALL SCRATCHES.
- GLOSS BLACK FINISHES SHOULD BE CLEANED WITH MILD SOAP AND WATER.



## PROCEDURE

1. Remove contents from box, verify if all parts listed are present and free from damage.  
Carefully read and understand all instructions before attempting installation.  
**Failure to identify damage before installation could lead to a rejection of any claim.**
2. Remove the bottom splash guard from the front bumper by removing the screws and push-clips at the top edge of the splash guard. Some vehicles will have two rivets at the outer edges of the splash guard. Drill with a 1/4" drill bit to remove. **(Figure 1)**
3. If the vehicle is not equipped with tow hooks, install the upper frame mounting brackets (ref. 2) to the driver side bumper mounting bracket using the factory bumper hardware and factory bumper bracket nuts. **(Figure 3)** Install loosely.
4. If the vehicle is equipped with tow hooks remove the two nuts that hold the front of the tow hook. **(Figure 2)**
5. Install the driver side lower frame mounting bracket to either the bottom of the tow hook or the provided upper frame mounting bracket using either the factory tow hook nuts or the supplied (4) M12 flat washers (zinc plated), (2) M12 lock washers (zinc plated), and (2) M12 hex nuts (zinc plated). Assemble loosely. **(Figure 4)**
6. Repeat **Steps 3 - 5** for the passenger side mounting bracket.
7. To reinstall the bottom splash guard to the vehicle, a slot must be cut to fit the lower mounting bracket. **(SEE PAGE 4)**
8. Attach the bull bar assembly to the lower frame mounting brackets using the supplied (4) M12 x 35MM coarse thread stainless steel hex bolts, (8) M12 flat washers, (4) M12 lock washers, and (4) M12 hex nuts. Assemble loosely. **(Figure 5)**
9. Attach the driver side support to the lower frame mounting bracket (ref. 3 & 4) and rear tow hook mount. If the vehicle is equipped with tow hooks, attach the rear of the support bracket to the bottom of the tow hook and use the factory bolt to secure. Use the rear bull bar assembly hole location and hardware to secure the front of the support bracket. **(Figures 4 and 5)**
10. To attach the support bracket when the vehicle is not equipped with a tow hook use the supplied M12 - 1.5 x 30MM fine thread yellow zinc hex bolt, flat washers, and lock washers to secure the rear of the support bracket (ref. 5 & 6). Use the supplied (2) M10 x 35MM hex bolts, (4) M10 flat washers, (2) M10 lock washers, and (2) M10 hex nuts to secure the front portion of the support bracket to the hole located above the bull bar holes on the lower support bracket. Assemble loosely.
11. At this time tighten all hardware. M12 (40-50 ft-lbs), M10 (20-30 ft-lbs), M 6(2-3 ft-lbs).
12. Reinstall the bottom splash guard using the factory clips and screws. For the applications that required rivets to be drilled out, use the supplied M6 hardware to secure the valance. **(Figure 6)**
13. **For part number 32-1965L:** Refer to **Page 5** for wiring instructions. Loosen M8 hardware to adjust the LED light in bull bar or to remove it in order to replace it. See **Figure 7** for location of M8 hardware.

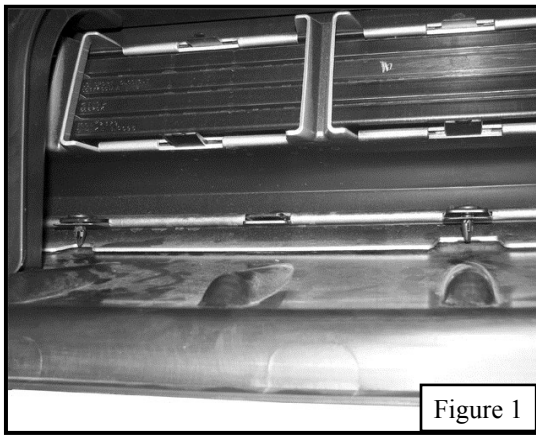

Figure 1

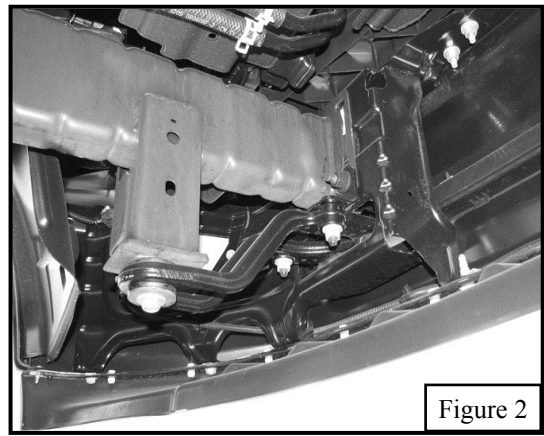
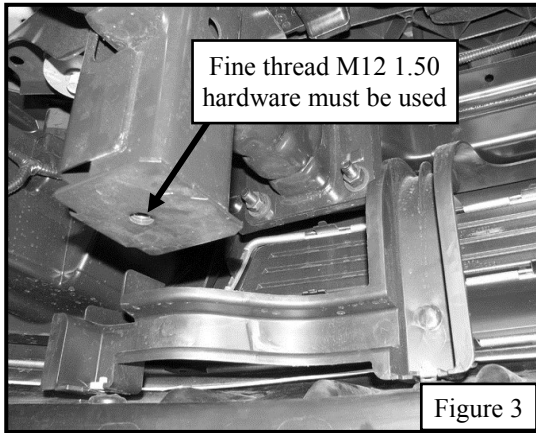

Figure 2



Fine thread M12 1.50 hardware must be used

Figure 3

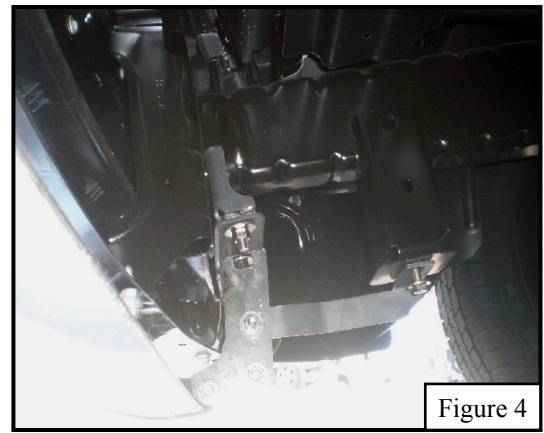

Figure 4

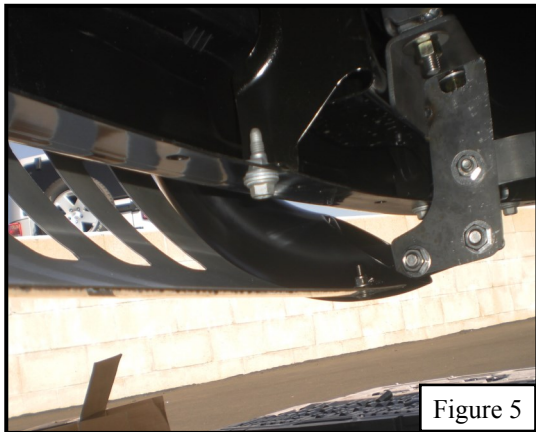

Figure 5

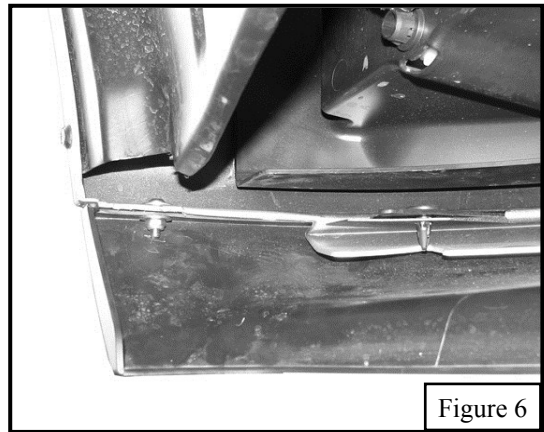
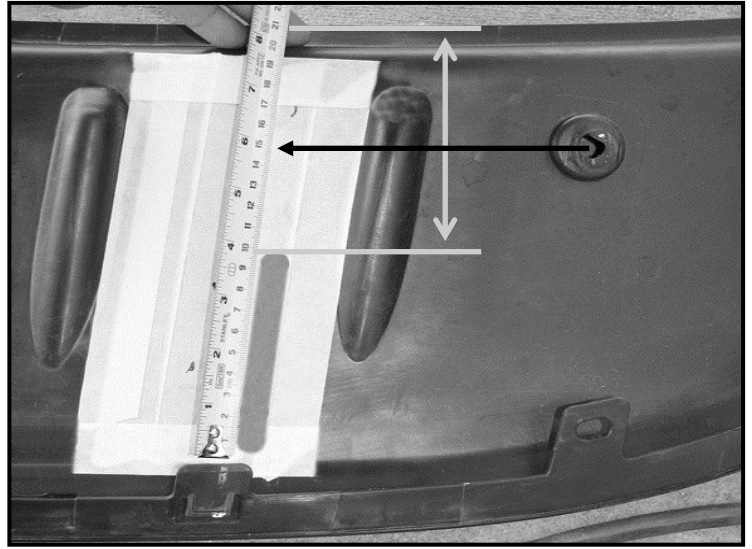
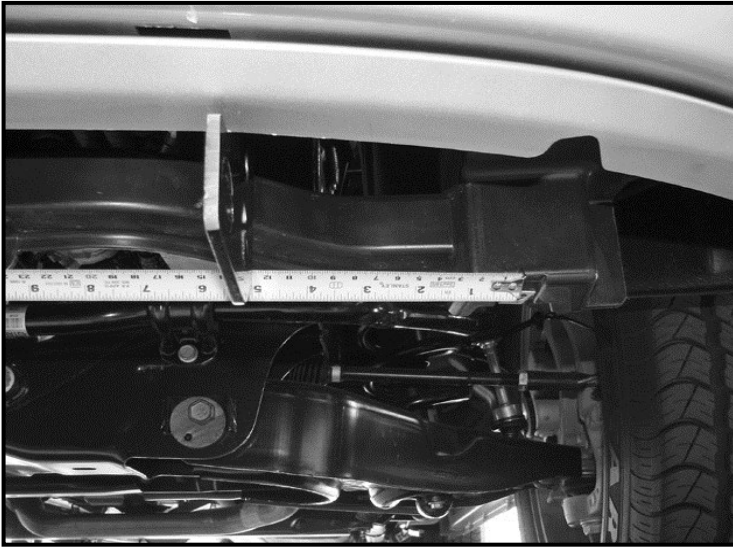

Figure 6



INSTALLATION COMPLETE

## TRIMMING INSTRUCTIONS



1. Measure the distance from the retaining clip hole to the edge of the mounting bracket. (Approx. 5")
2. Cut a slot approximately 1/2" wide x 4" long into valance about 5" from the end.
3. Install valance and verify proper fitment. Additional trimming may be necessary.

## WIRING INSTRUCTIONS FOR 32-1965L:

WESTIN recommends using a professional for this installation.

### CAUTION:

1. Disconnect ground connection from battery (-) to avoid accidental short circuits before attempting to connect electrical wires.
2. When running wires, avoid areas of excessive heat, vibration, pinch or rotation when securing harness to vehicle.
3. Always use a fused (+) positive supply source.
4. This light becomes hot under continuous use. Do not remove or touch the casting for at least 30 minutes after the lamp has been turned off.

### Refer to Figure 8.

1. Locate wiring harness and mount the switch in a convenient location where it is easily accessible from the drivers seat.  
**Note:** *The switch will need to be removed from the wiring harness so that the rest of the harness can be routed from the engine bay to the cabin.*
2. Route the wiring harness wire, specifically the fuse and relay, from the positive battery terminal along the firewalls existing wire routes. **Note:** *Tape as necessary to correct slack.*
3. Secure the relay by either drilling or using a pre-existing bolt along the chassis that is not connected to any other wire.
4. Run the switch harness through the firewall preferably through the pre-existing rubber plug that is used to run the OEM wiring harness from the engine bay to fuse box. **Note:** *Reconnect the switch to the wiring harness.*
5. Place the LED plug wire along the fender chassis where it will not get pinched and away from any moving parts (fan, pulleys etc.).
6. Run the attached wire from the LED Light Bar as previously mentioned away from any moving parts.
7. Connect both ends of wiring connectors from LED light bar and wiring harness.
8. Re-connect battery terminals, attach the Red (+) wire to battery positive, and the black (-) wire to ground. **Note:** *Add dielectric grease (not supplied).*
9. Turn on the switch to make sure if the lamp works. If not, please check carefully if the wiring installation is correct.

M8 hardware attaches LED light onto bull bar.

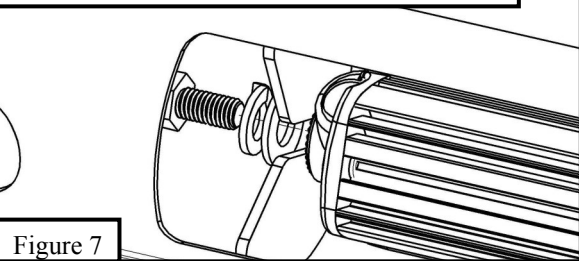

Figure 7

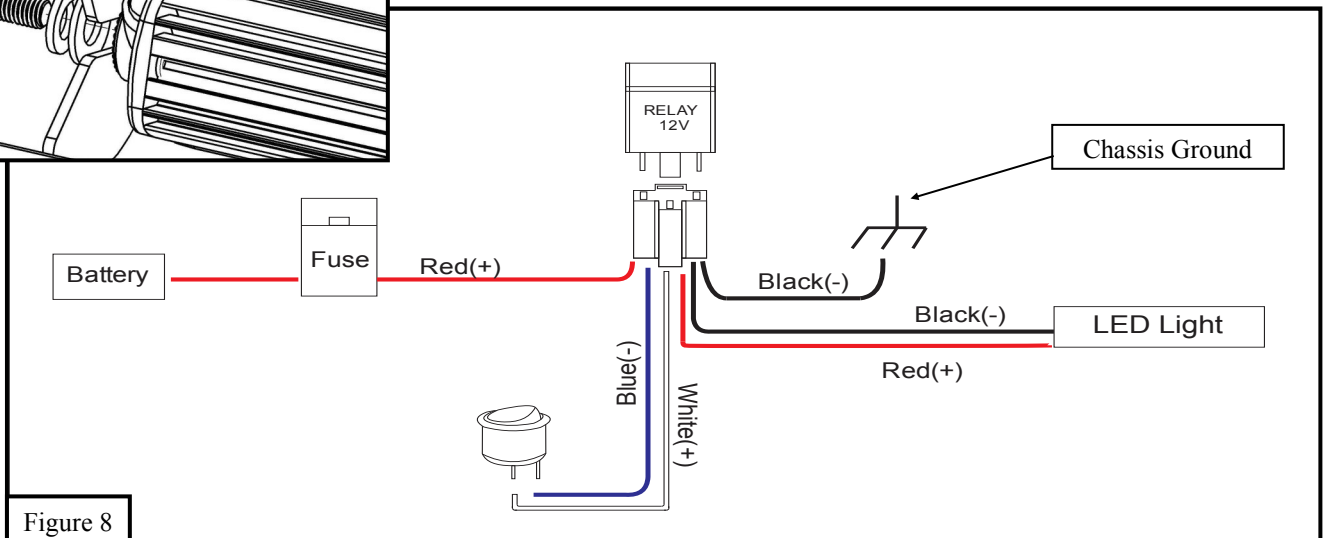

Figure 8

# Westin

SIGNATURE OF QUALITY

AUTOMOTIVE PRODUCTS, INC.



## WARNING



Failure to follow these instructions could lead to death, personal injury, and / or property damage.

### FASTENERS:

All Westin supplied fasteners must be utilized and installed in accordance with the installation instructions and apply torque to the specifications as defined. **DOUBLE CHECK ALL FASTENERS BEFORE INITIAL USE, AND PERIODICALLY IN THE FUTURE TO ENSURE PROPER FUNCTION AND SAFETY.**

### DRILLING:

Most Westin products do not require drilling for installation. If drilling is defined as required, use caution when drilling a vehicle. **FAILURE TO REVIEW AN AREA TO BE DRILLED MAY RESULT IN PERSONAL INJURY AND/OR INJURY TO OTHERS AS WELL AS VEHICLE DAMAGE.**

### EYE PROTECTION:

**ALWAYS WEAR SAFETY GLASSES OR GOGGLES DURING THE INSTALLATION PROCESS TO AVOID PERSONAL INJURY.**

### MAXIMUM TOWING/CARRYING CAPACITY:

The Westin Receiver Hitches will have a visible tow rating label affixed directly on the product. User should never exceed the vehicle manufacturers maximum tow and weight rating regardless of the capacity of the hitch. **FAILURE TO FOLLOW THESE GUIDELINES WILL VOID THE WESTIN WARRANTY AND MAY RESULT IN PERSONAL INJURY AND/OR INJURY TO OTHERS AS WELL AS VEHICLE DAMAGE.**

---

---

# Westin.

SIGNATURE OF QUALITY

P.N.: 75-0906-RevH

Learn more about grille guards and bull bars we have.