

INSTALLATION INSTRUCTIONS

E-SERIES BULL BAR



APPLICATION:
2020 Chevrolet Silverado 2500/3500
PART NUMBER:
31-6020, 31-6025

CONTENT			
ITEM	QUANTITY	DESCRIPTION	TOOLS NEEDED
1	1	BULL BAR	19MM SOCKET
2	1	DRIVER MOUNTING BRACKET	RATCHET
3	1	PASSENGER MOUNTING BRACKET	TORQUE WRENCH
4	4	M12 HEX HEAD BOLT (YELLOW ZINC)	19MM WRENCH
5	8	M12 FLAT WASHER (YELLOW ZINC)	PRY BAR
6	4	M12 SPLIT LOCK WASHER (YELLOW ZINC)	ALLEN WRENCH
7	4	M12 HEX NUT (YELLOW ZINC)	
8	4	M10 BUTTON HEAD BOLT (BLACK ZINC)	
9	4	M10 FLAT WASHER (BLACK ZINC)	
10	4	M10 SERRATED FLANGE NUT (BLACK ZINC)	

ANTI-SEIZE LUBRICANT MUST BE USED ON ALL STAINLESS STEEL FASTENERS TO PREVENT THREAD DAMAGE AND GALLING

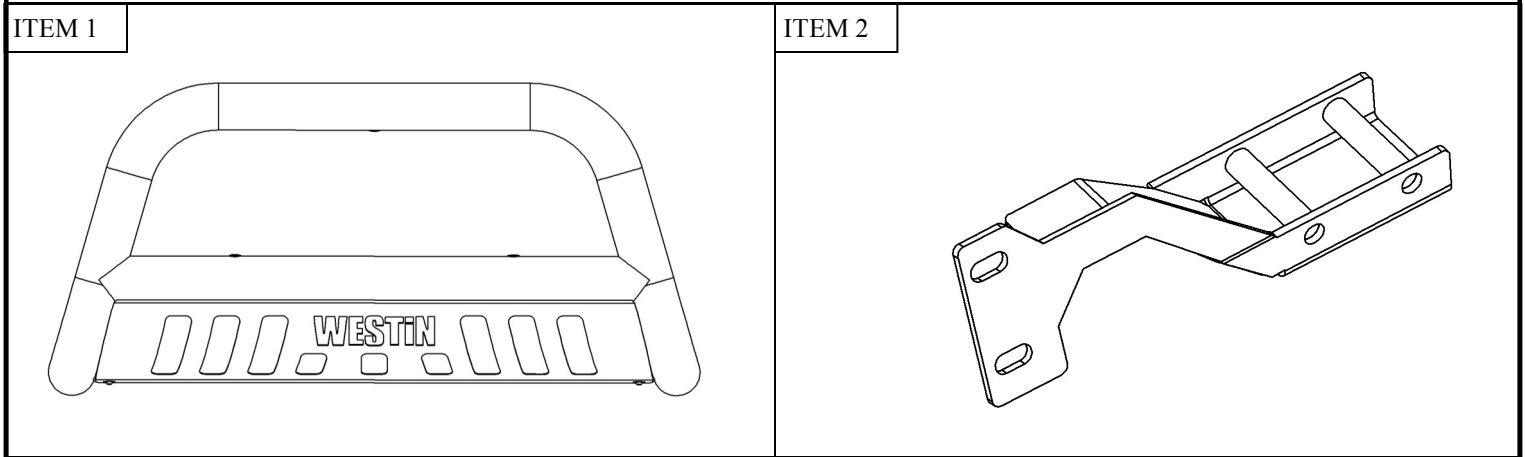

NOTE: THIS BULL BAR WILL PROHIBIT THE FUNCTION OF FRONT PARKING SENSORS ON YOUR VEHICLE IF EQUIPPED.

PROCEDURE

1. Remove contents from box, verify if all parts listed are present and free from damage.
Carefully read and understand all instructions before attempting installation.
Failure to identify damage before installation could lead to a rejection of any claim.



2. Start by removing the front plastic cover on the front bumper. Remove the screws holding it on. See Figure 1.

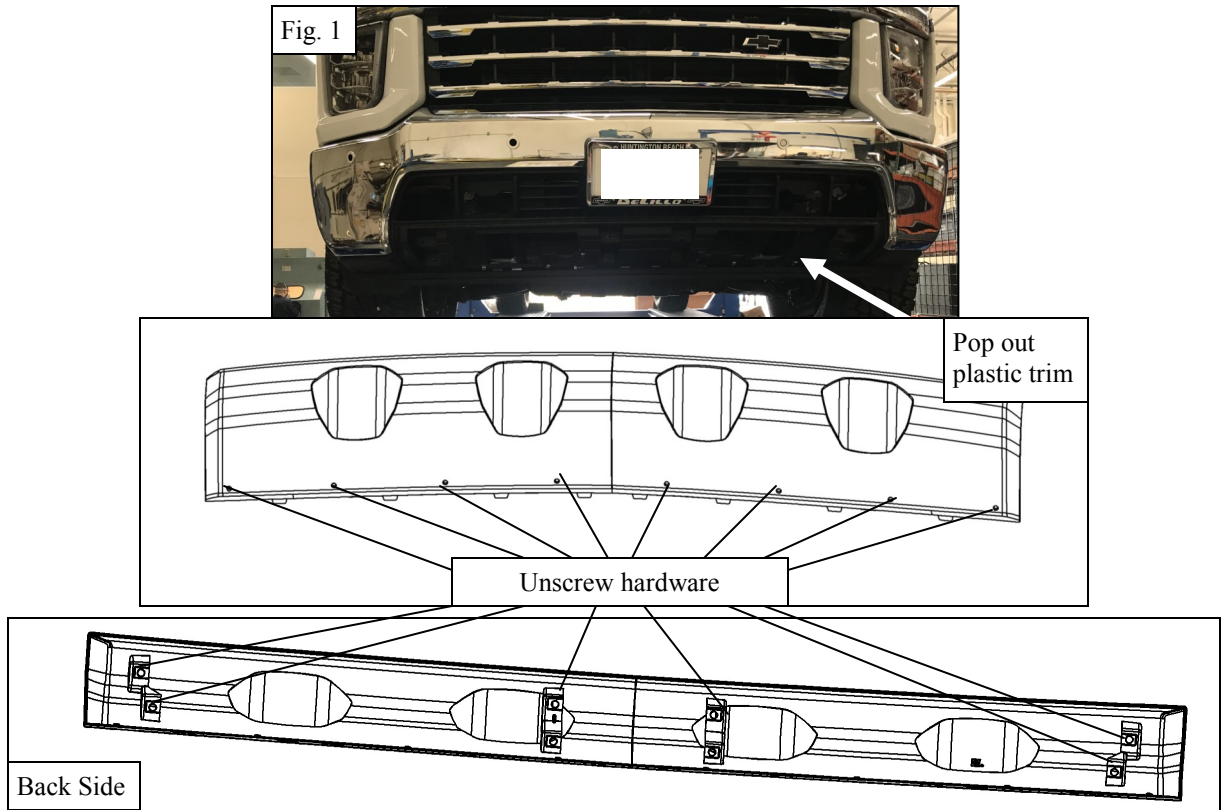

3. If equipped, remove the tow hooks from the vehicle. **Note: Factory Tow hooks will not be re-used.**
4. **Note: Trimming of tow pocket is required.** Trim the tow hook pockets as necessary for mounting bracket clearance. See Figure 2.

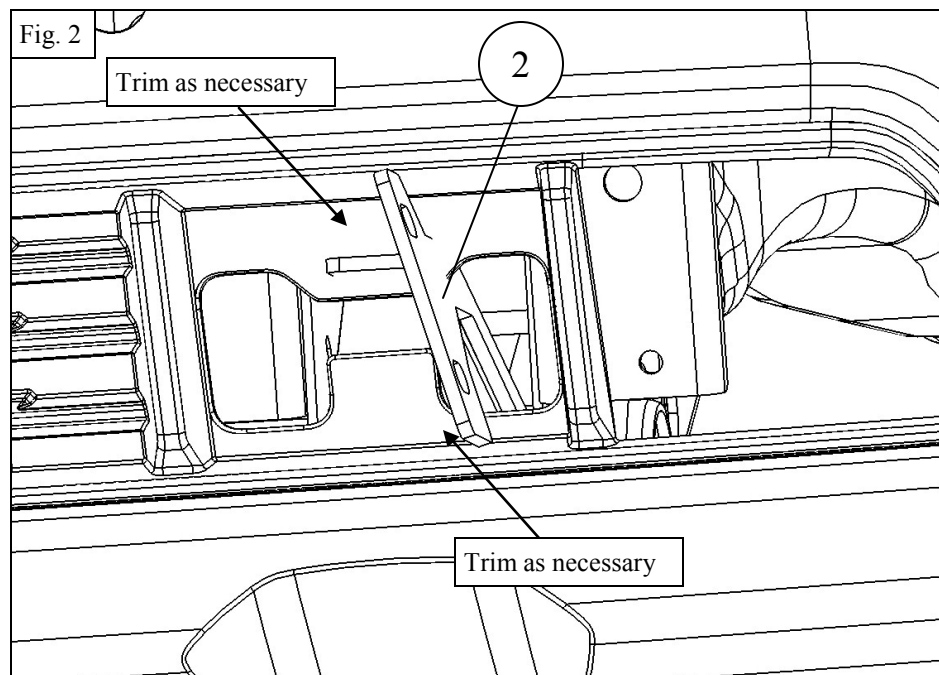

5. Locate the driver mounting bracket for the bull bar. Using the supplied M12 hardware, loosely install the mounting bracket on to the frame. Slide the mounting bracket (2) in between the frame. **See Figure 3.** *Note: The frame rails on these vehicles can vary in tolerance. If the mounting bracket does not fit inside the frame rail, use a pry bar to widen out the opening as necessary.*
6. Repeat on the passenger side.
7. Re-install plastic cover on bumper that was removed in step 2.

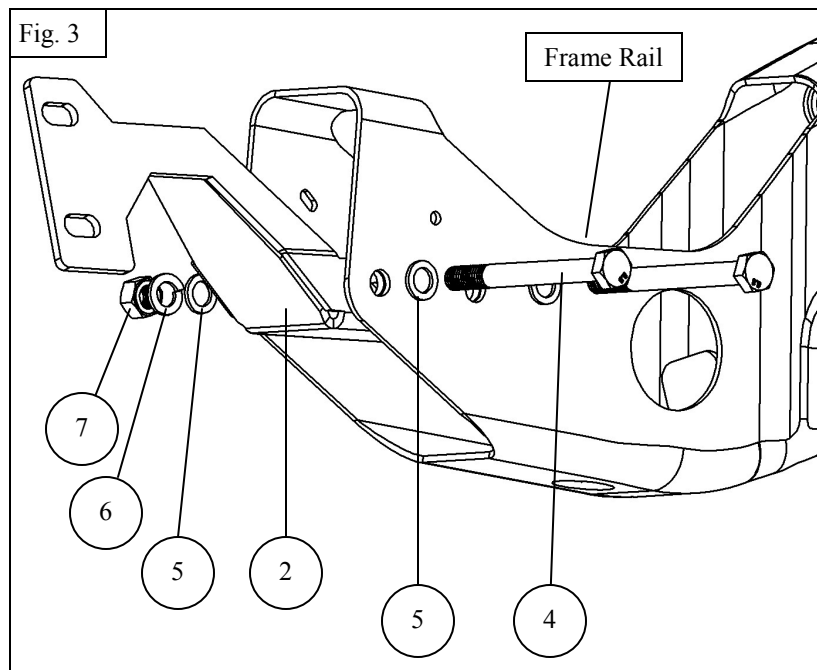

7. Using supplied M10 hardware, loosely assemble the bull bar on to the mounting brackets. **See Figure 4.**
8. Adjust the bull bar as necessary and torque all hardware to the following: M10 to 35-40 ft-lbs; M12 to 50-55 ft-lbs.

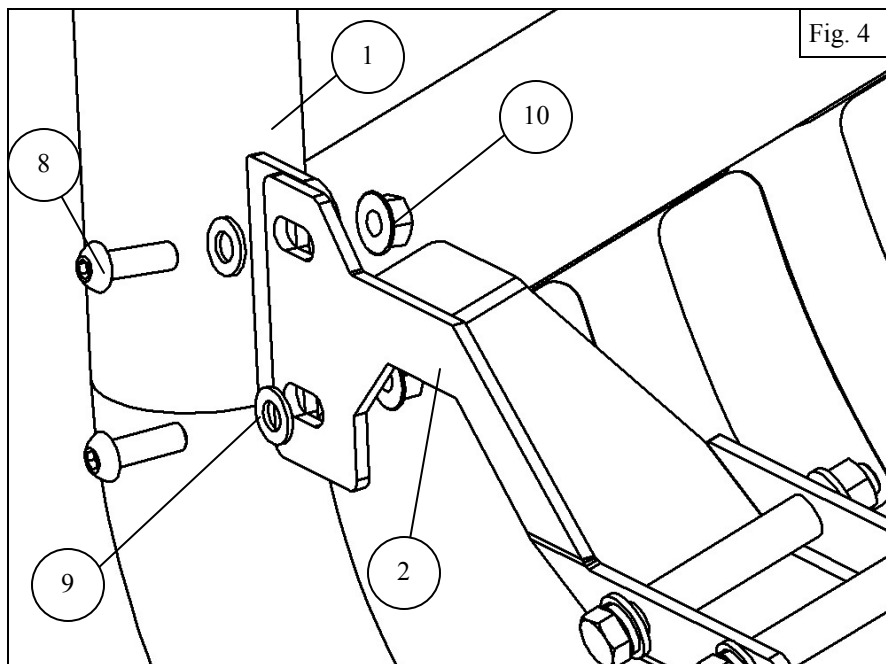

INSTALLATION COMPLETED



CARE INSTRUCTIONS

- REGULAR WAXING IS RECOMMENDED. DO NOT USE ANY TYPE OF POLISH OR WAX THAT MAY CONTAIN ABRASIVES.
- STAINLESS STEEL PRODUCTS CAN BE CLEANED WITH MILD SOAP AND WATER. STAINLESS STEEL POLISH SHOULD BE USED TO POLISH SMALL SCRATCHES.
- GLOSS BLACK FINISHES SHOULD BE CLEANED WITH MILD SOAP AND WATER.

WESTiN