



# INSTALLATION INSTRUCTIONS

APPLICATION: 2015 CHEVY COLORADO/GMC CANYON  
APP PART# 31-5120  
3" BULL BAR

AUTOMOTIVE PRODUCTS, INC.

ITEM	QUANTITY	DESCRIPTION	TOOLS NEEDED
1	1	BULL BAR/SKID PLATE ASSEMBLY	18MM SOCKET
2	1	DRIVER(LEFT) MOUNTING BRACKET	18MM WRENCH
3	1	PASSENGER(RIGHT) MOUNTING BRACKET	15MM WRENCH
4	4	M12-1.75X80 HEX HEAD CAP SCREW, CLASS 8.8 (YELLOW ZINC)	16MM SOCKET
5	4	M12 FLAT WASHER, 24MM OD X 2.5MM THICK (YELLOW ZINC)	RATCHET
6	4	M12 SERRATED FLANGE NUT, CLASS 8 (YELLOW ZINC)	TORQUE WRENCH
7	4	M10-1.50X30 HEX HEAD CAP SCREW (STAINLESS STEEL)	
8	4	M10 BELLVILLE WASHERS (STAINLESS STEEL)	
9	4	M10-1.50 SERRATED FLANGE NUT (STAINLESS STEEL)	

**ANTI-SEIZE LUBRICANT MUST BE USED ON ALL STAINLESS STEEL FASTENERS TO PREVENT THREAD DAMAGE AND GALLING**

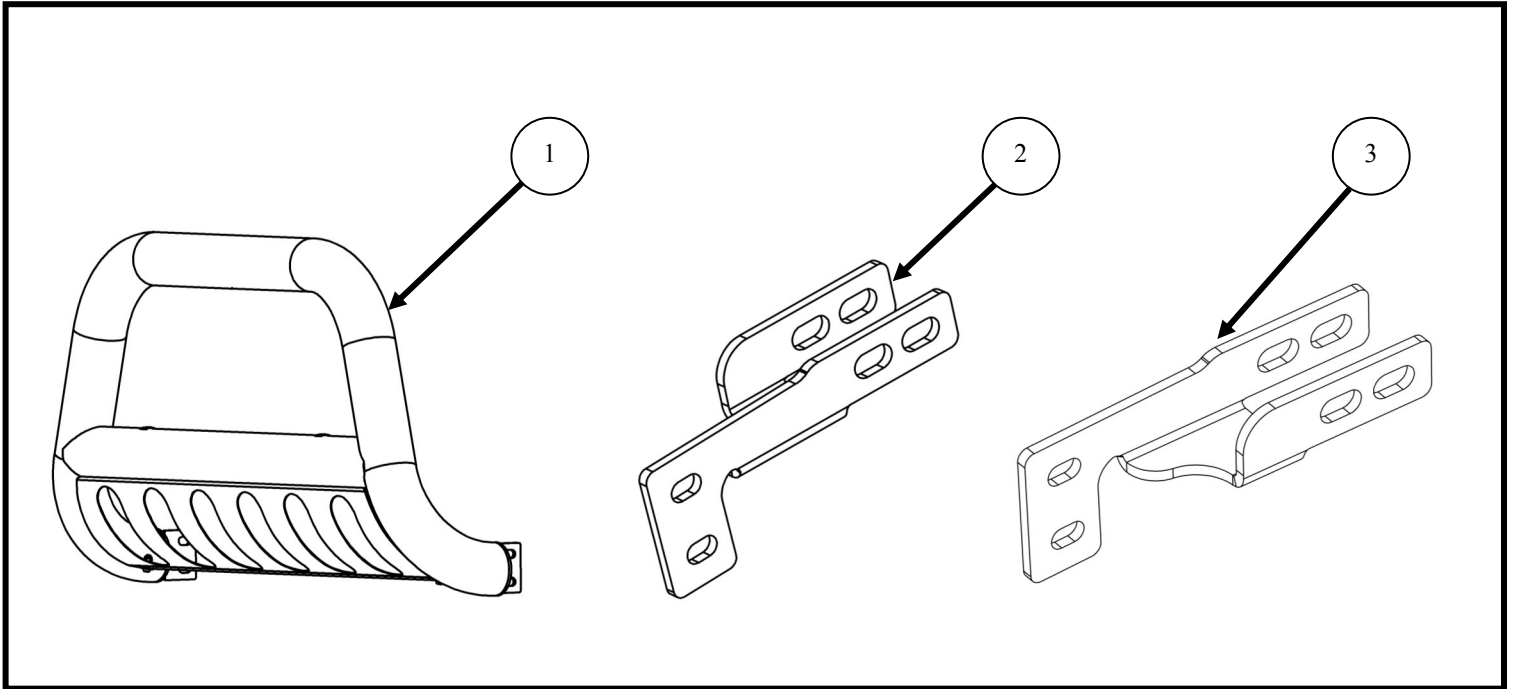

Thank You for choosing Westin products.

## PROCEDURE

**NOTE:** It may be necessary to remove/relocate the front license plate and license plate bracket. It is not required, but strongly recommended. If local/state law requires a front license plate, license plate relocation kit is available.

1. Remove contents from box, verify if all parts listed are present and free from damage. Carefully read and understand all instructions before attempting installation. Cutting may be required and installation may interfere with front mounted sensors.
2. Start installation from under the front of the vehicle. Remove the plastic splash guard from below/behind the bumper (**FIG 1**). Determine if the vehicle is equipped with tow hooks. **IMPORTANT:** Tow hooks cannot be reinstalled with the bull bar. Also, it may be necessary to temporarily remove the factory skid plate (if equipped), to access the mounting locations.

### Tow Hook equipped vehicles:

- a. Remove the driver side tow hook and hardware from the end of the frame channel (**Figures 2 & 3**). Also remove the seal between the opening in the bumper and the tow hook (**FIG 4**).
- b. Repeat to remove the passenger side tow hook.
- c. Proceed to **Step 2**.

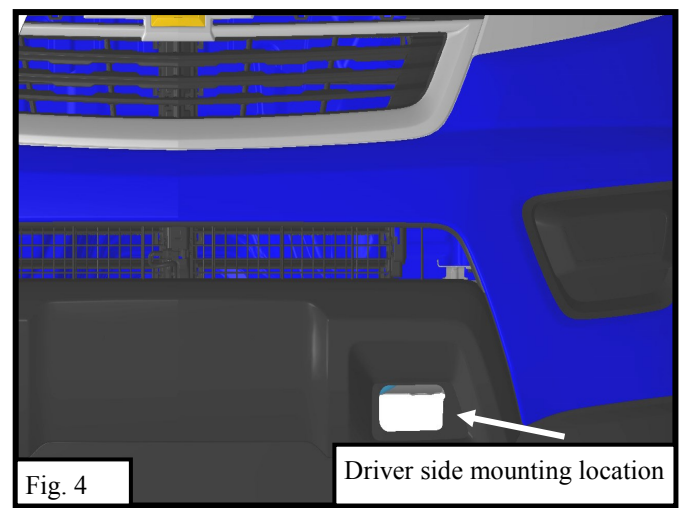
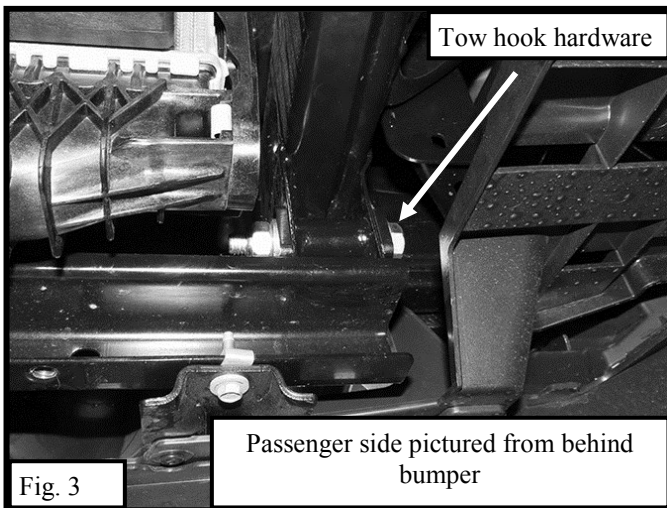
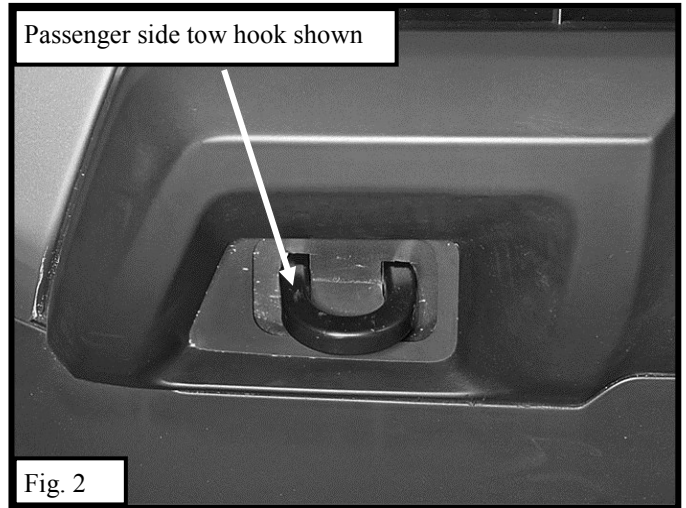
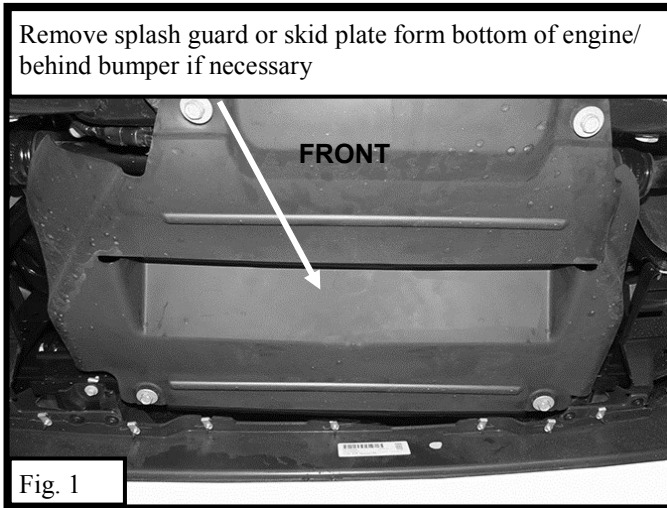

**Vehicles without tow hooks:**

- a. Cut out the indented area in both sides of the plastic bumper to clear the brackets as pictured in **Figures 4 & 5**, or cut along the rectangular cut line molded into the pocket.
3. Select the driver side mounting bracket. Insert the bracket through the opening in the bumper and up to the tow hook mounting holes (**FIG 6**). Trim the plastic as required for bracket clearance. **NOTE:** Bumper removal not necessary.
4. Line up the (2) holes in the bracket with the (2) holes in the frame for the tow hook. Select (2) M12-1.75X80 hex head cap screws and (2) 12mm flat washers. Insert the bolts with washers through the bracket and the (2) holes through the frame. Secure bolts with (2) 12mm serrated flange nuts. Do not fully tighten hardware at this time. Refer to **Figure 7**.
5. Repeat **steps 3 & 4** to install the passenger side mounting bracket.
6. With assistance, hold the bull bar up in position on the outside of the mounting brackets. Bolt the bull bar to the brackets with (4) M10-1.50X30 hex head cap screws, (4) M10 bellville washers, and (4) M10-1.50 serrated flange nuts. See **Figure 7**. Do not tighten hardware at this time.
7. Check the bull bar alignment with the vehicle and for clearance between the bull bar and the bumper. Adjust as required then fully tighten all hardware at this time. See **Figure 8** for a picture of bull bar mounted on vehicle.
8. Reinstall the plastic splash guard or skid plate removed in **Step 1 (FIG 1)**.
9. Do periodic inspections to the installation to make sure that all hardware is secure and tight.

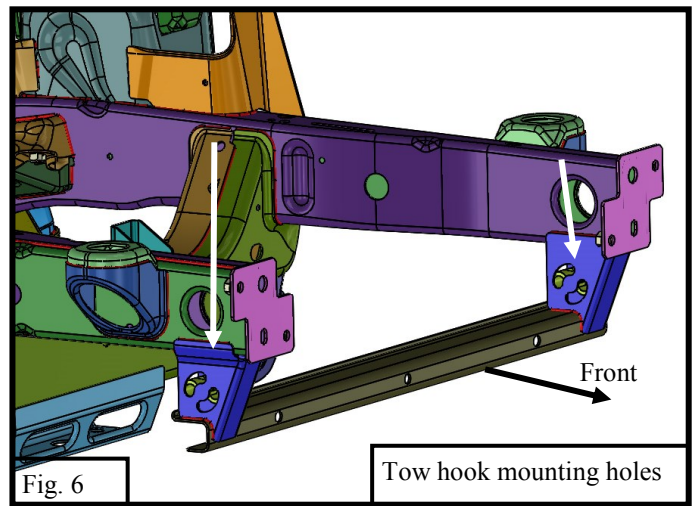
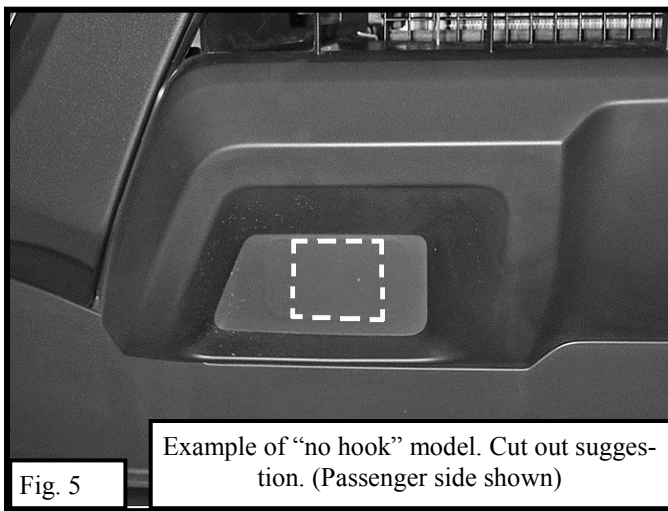

Bull bar hardware assembly

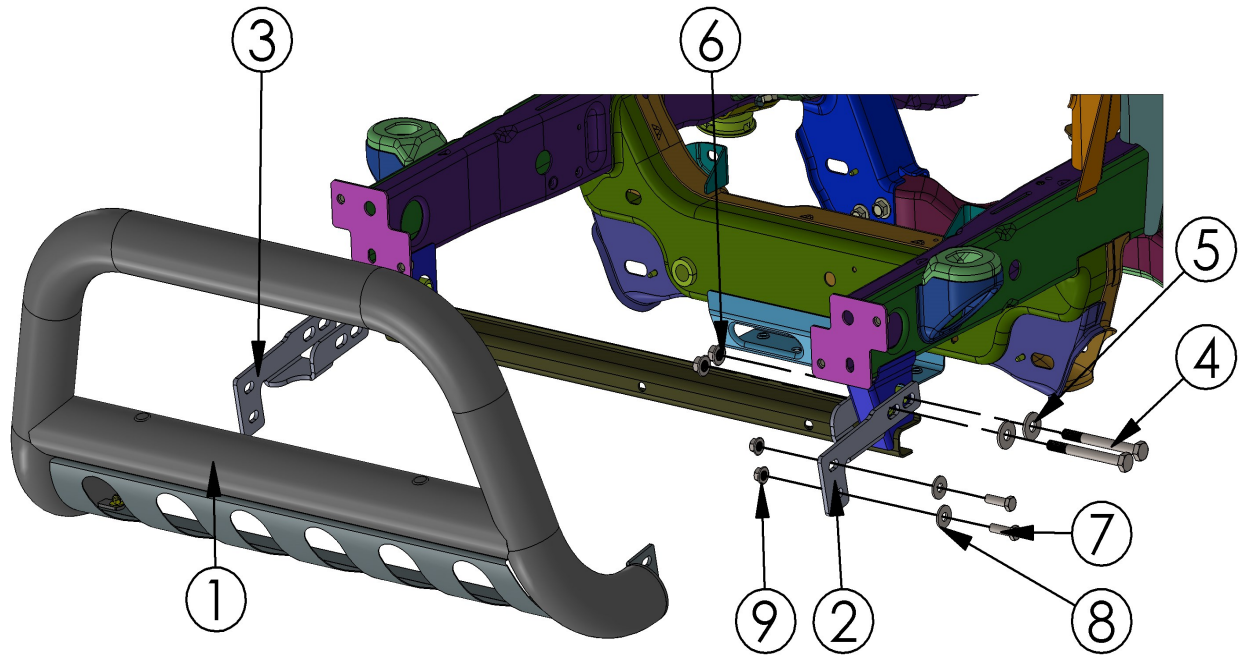

Fig. 7

Final assembly on vehicle

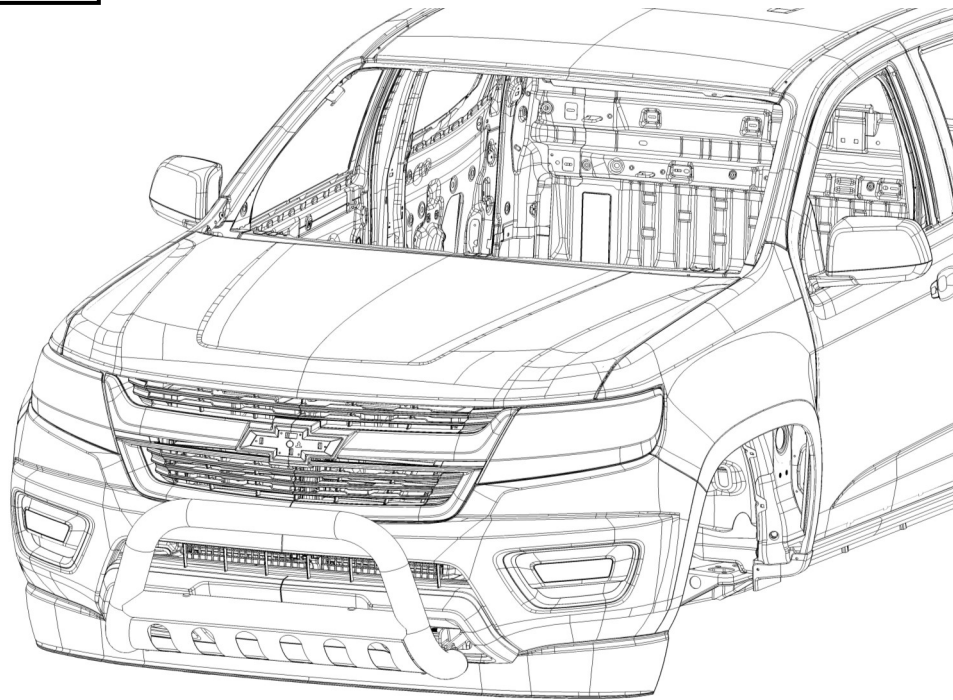

Fig. 8



CARE INSTRUCTIONS

- REGULAR WAXING IS RECOMMENDED. DO NOT USE ANY TYPE OF POLISH OR WAX THAT MAY CONTAIN ABRASIVES.
- STAINLESS STEEL PRODUCTS CAN BE CLEANED WITH MILD SOAP AND WATER. STAINLESS STEEL POLISH SHOULD BE USED TO POLISH SMALL SCRATCHES.
- GLOSS BLACK FINISHES SHOULD BE CLEANED WITH MILD SOAP AND WATER.



Thank You for choosing Westin products.