

INSTALLATION INSTRUCTIONS

E-SERIES BULL BAR



APPLICATION:
2019-2020 RAM 2500/3500
PART NUMBER:
31-4020, 31-4025

CONTENT			
ITEM	QUANTITY	DESCRIPTION	TOOLS NEEDED
1	1	BULL BAR	17MM SOCKET
2	1	DRIVER MOUNTING BRACKET	17MM WRENCH
3	1	PASSENGER MOUNTING BRACKET	RATCHET
4	2	M12 HEX HEAD BOLT (YELLOW ZINC)	TORQUE WRENCH
5	2	M12 FLAT WASHERS (YELLOW ZINC)	ALLEN
6	2	M12 SERRATED FLANGE NUT (YELLOW ZINC)	21MM SOCKET
7	4	M10 BUTTON HEAD BOLT (BLACK ZINC)	18MM WRENCH
8	4	M10 FLAT WASHER (BLACK ZINC)	18MM SOCKET
9	4	M10 SERRATED FLANGE NUT (BLACK ZINC)	BREAKER BAR
10	4	M10 SPLIT LOCK WASHER (BLACK ZINC)	

ANTI-SEIZE LUBRICANT MUST BE USED ON ALL STAINLESS STEEL FASTENERS TO PREVENT THREAD DAMAGE AND GALLING

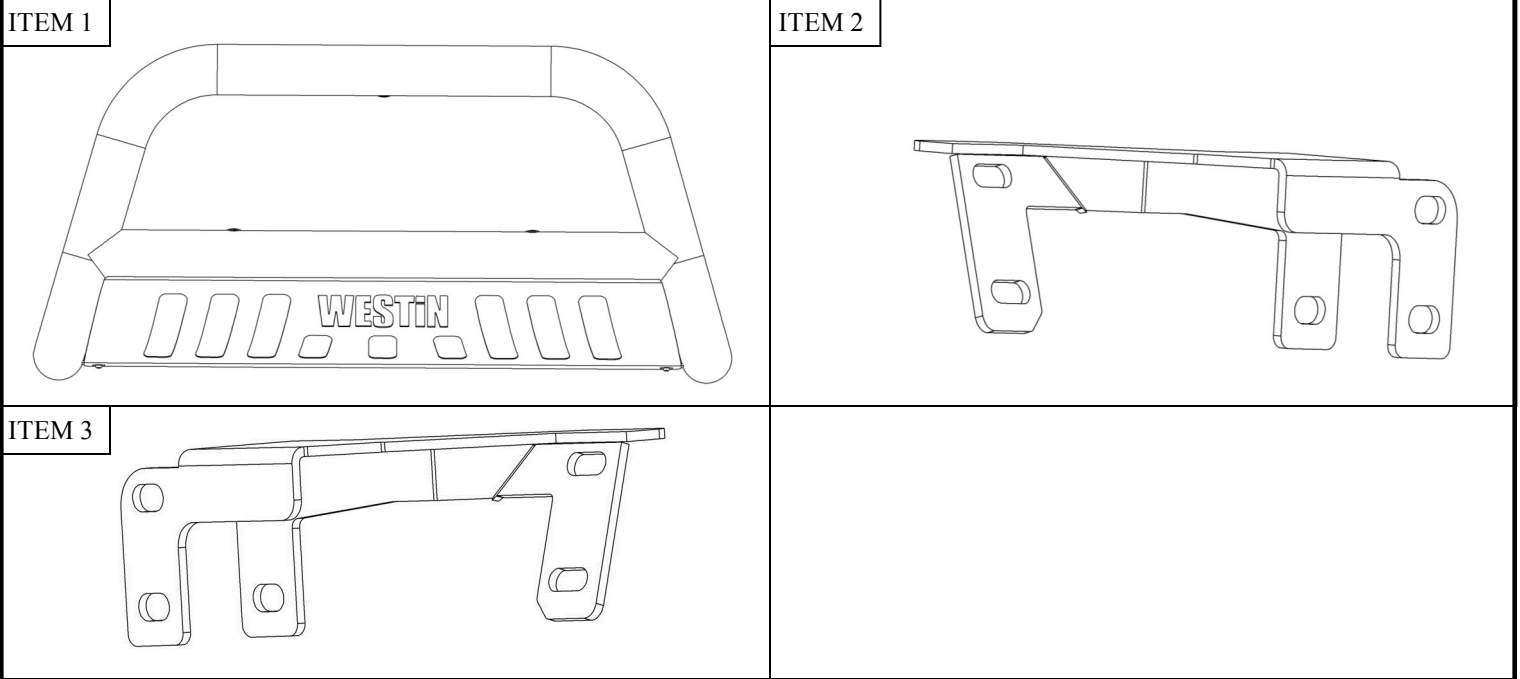

PROCEDURE

1. Remove contents from box, verify if all parts listed are present and free from damage.
Carefully read and understand all instructions before attempting installation.
Failure to identify damage before installation could lead to a rejection of any claim.



2. Start below the front of the vehicle. Unbolt the two factory bolts (three if tow hooks are equipped) from the bumper bracket on each side. See **Figure 1**. *Note: Factory Tow hooks cannot be reused!*

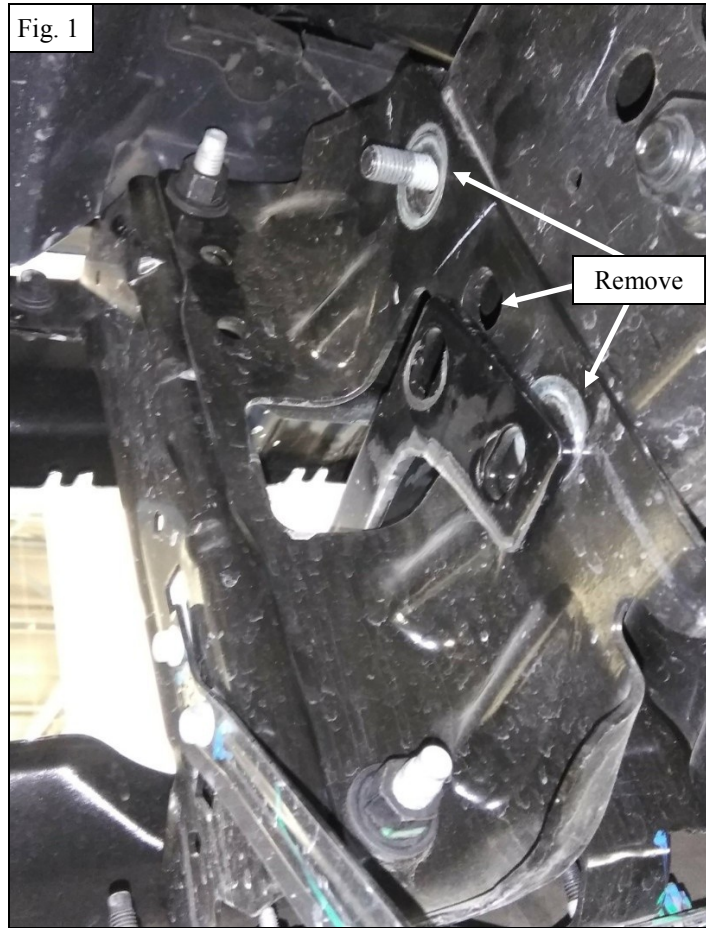

3. Unplug any lights or wiring and remove the bumper.
4. Remove the top nuts off of each bumper bracket. Remove the bracket. See **Figure 2**



5. Slide either mounting bracket (2,3) into the factory bumper bracket as shown in **Figure 3**.

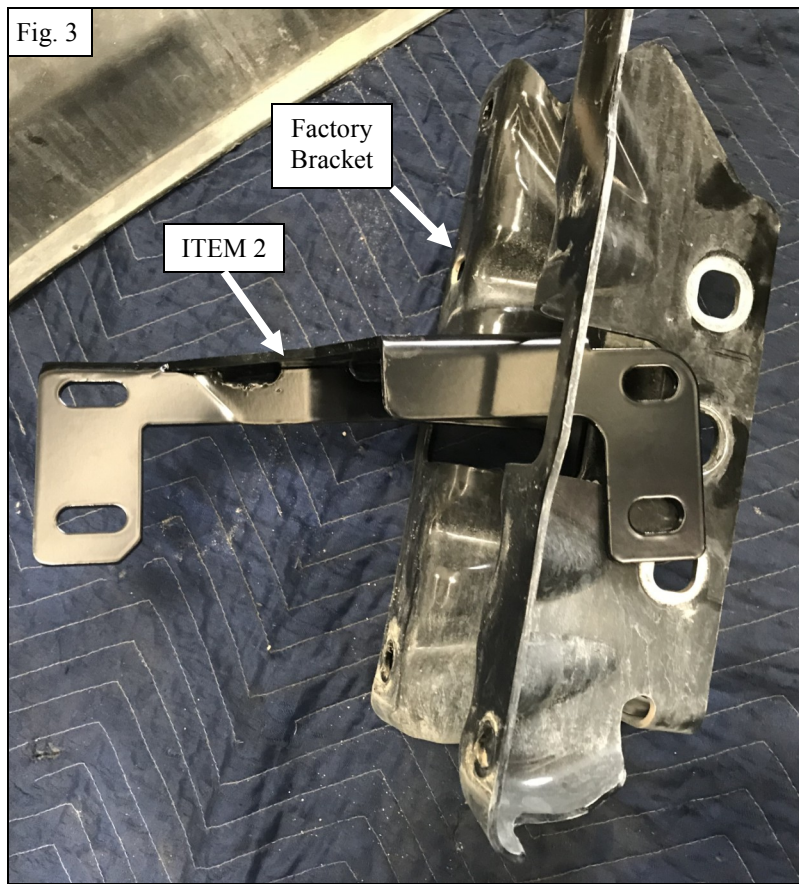

6. Rotate and slide both brackets back through the front bumper as shown in **Figures 4-5**

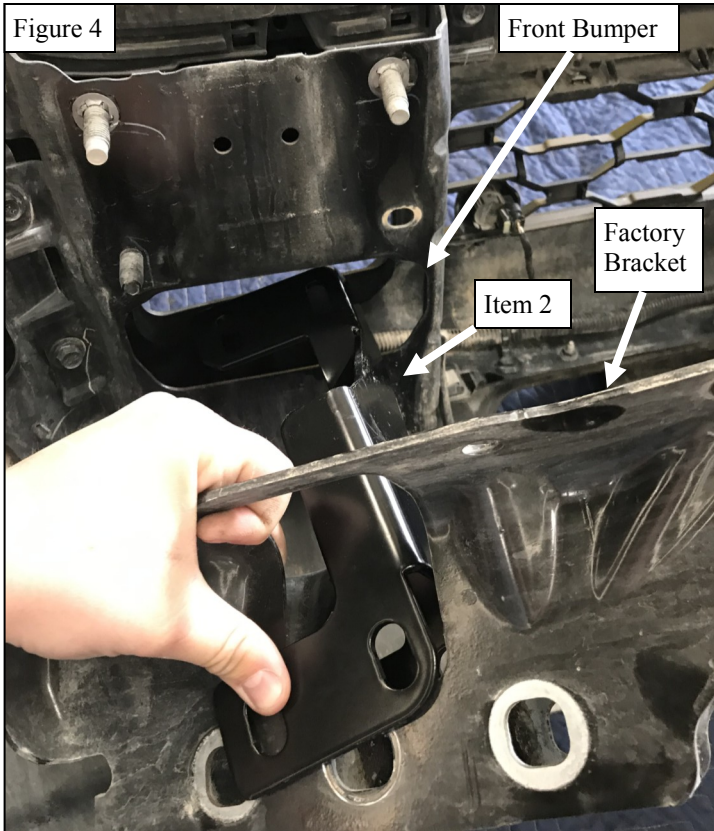

7. Re-Install the factory bumper bracket to the bumper.
8. Using supplied M12 hardware and reusing factory hardware, loosely install the mounting bracket. Re install the front bumper and torque to factory specs. The brackets should slide through the tow hook pockets. See **Figure 6**

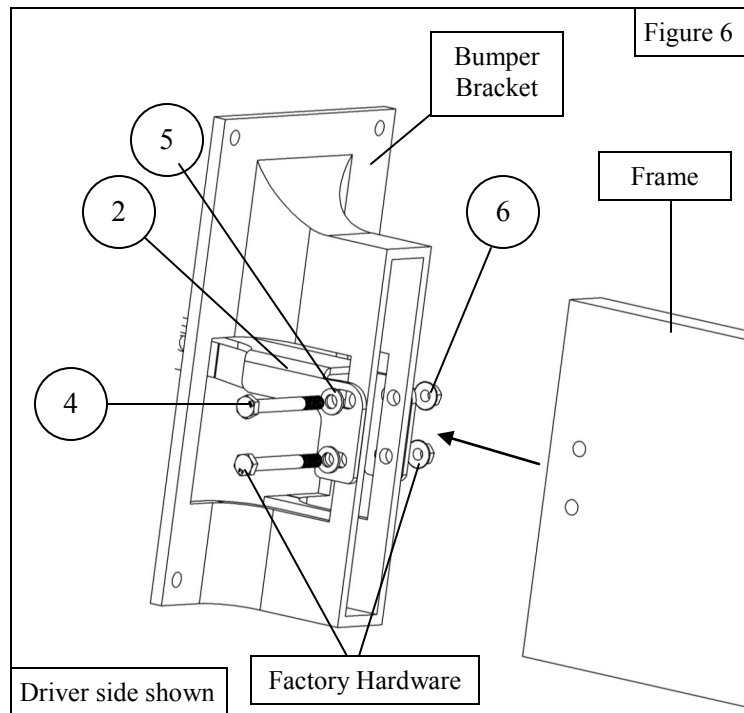

9. Using the supplied M10 hardware, loosely install the bull bar to the mounting brackets. See Figure 7.

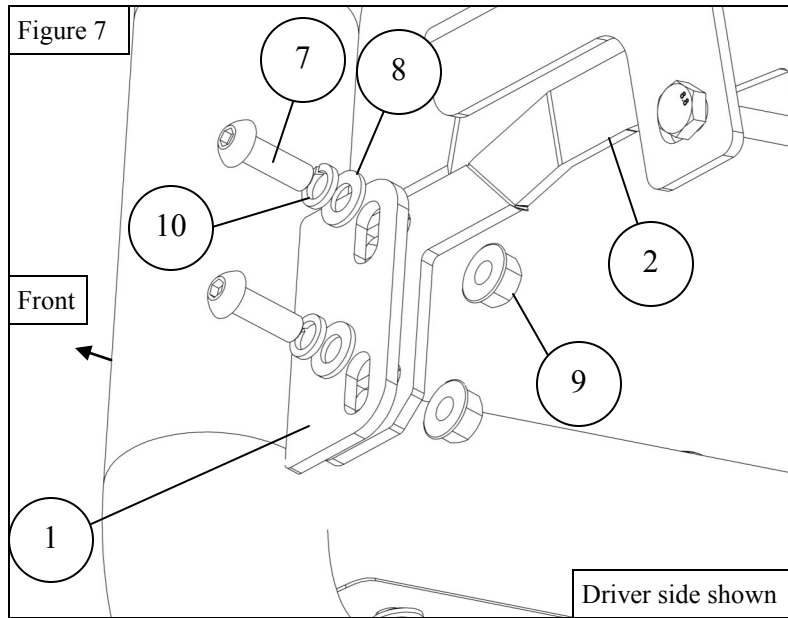

11. Align bull bar as necessary and torque hardware as specified: M10 to 40 ft-lbs, M12 to 60 ft-lbs.



CARE INSTRUCTIONS

- REGULAR WAXING IS RECOMMENDED. DO NOT USE ANY TYPE OF POLISH OR WAX THAT MAY CONTAIN ABRASIVES.
- STAINLESS STEEL PRODUCTS CAN BE CLEANED WITH MILD SOAP AND WATER. STAINLESS STEEL POLISH SHOULD BE USED TO POLISH SMALL SCRATCHES.
- GLOSS BLACK FINISHES SHOULD BE CLEANED WITH MILD SOAP AND WATER.

WESTIN