



SIGNATURE OF QUALITY

AUTOMOTIVE PRODUCTS, INC.

INSTRUCTIONS

APPLICATION: 1996-01 FORD EXPLORER 1998-00 FORD RANGER
1997-01 MERCURY MOUNTAINEER

SAFARI BAR ASSEMBLY 30-0000 30-0005 MOUNT KIT 30-1055						
--	--	--	--	--	--	--

ITEM	QTY	CONTENTS	TOOLS
1	1	SAFARI BAR ASSEMBLY (PURCHASED SEPARATELY)	3/4" SOCKET 3/4" WRENCH 9/16" SOCKET 9/16" WRENCH 1/2" SOCKET 10MM SOCKET RATCHET RATCHET EXTENSION TORQUE WRENCH
2,3	2	BRACKET, PASSENGER (2) AND DRIVER (3)	
4,5	2	SUPPORT BRACE, PASSENGER (4) AND DRIVER (5)	
6	2	BACKING PLATE	
7	2	1/2-13 X 4.00" HEX HEAD BOLT	
8	2	1/2-13 X 2.00" HEX HEAD BOLT	
9	6	1/2" FLAT WASHER	
10	4	1/2" LOCK WASHER	
11	2	1/2-13 HEX NUT	
12	2	3/8-16 X 1.50" HEX HEAD BOLT	
13	4	3/8" FLAT WASHER (NOT SHOWN)	
14	2	3/8" LOCK WASHER (NOT SHOWN)	
15	2	3/8-16 HEX NUT (NOT SHOWN)	
16	4	5/16-18 X 1.00" SELF TAPPING SCREW (NOT SHOWN)	

- STEP 1. Remove the contents from box and check for damage. Verify all parts are present. Read instructions completely before beginning.
- STEP 2. Attach brackets on outside face of frame members with 1/2-13 x 4.00" hex head bolts.
NOTE: 4 Door applications use upper holes. **SEE FIGURE 1.**
NOTE: Explorer "Sport" and Ranger uses lower holes. **SEE FIGURE 2.** Secure with backing plates and 1/2" fasteners. **SEE FIGURE 3.** Leave loose.
- STEP 3. Attach support braces using holes in bottom face of vehicle frame. **NOTE:** 1996-97 models: Secure to frame using 5/16" self tapping screws. **SEE FIGURES 1 AND 2.** 1998 models have a factory bolt in rear hole to hold radiator shroud. **SEE FIGURES 1 AND 2.** Remove "push type" fasteners holding rear of shroud to frame. Attach support braces between top of shroud and frame. Replace factory bolts. Replace push type fasteners with 5/16" self tapping screws. Leave loose.
- STEP 4. Attach support brace to brackets using 3/8" fasteners. **SEE FIGURES 1 AND 2.**
- STEP 5. Attach Safari Bar using 1/2" fasteners. **SEE FIGURES 1-4.**
- STEP 6. Level and adjust Safari Bar as desired and tighten all fasteners. Recommended torque values are 64 Ft. Lbs. for 1/2" fasteners, 26 Ft. Lbs. for 3/8" fasteners, 16 Ft. Lbs. for 8mm fasteners, and 15 Ft. Lbs. for 5/16" fasteners.

FINISH PROTECTION

Westin products have a high quality finish that must be cared for like any other exposed finish on the vehicle. Protect the finish with a non-abrasive automotive wax, (e.g. Pure Carnauba) on a regular basis. The use of any soap, polish or wax that contains an abrasive is detrimental, as the compounds scratch the finish and open it to corrosion.

FIGURE 1
4 DOOR APPLICATIONS
DRIVER SIDE SHOWN

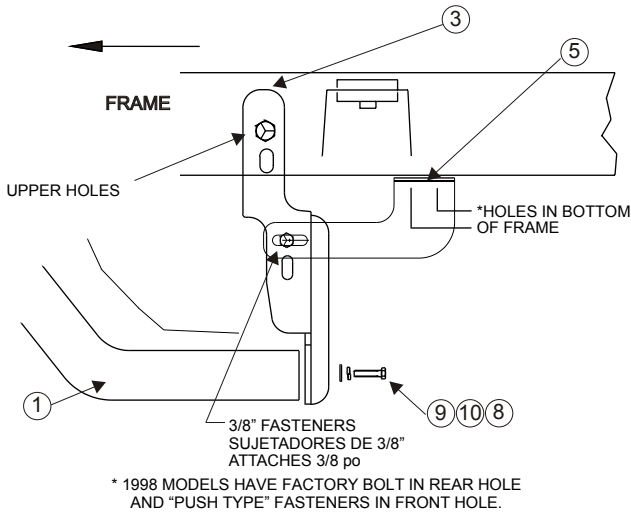

FIGURE 2
EXPLORER SPORT & RANGER DRIVER
SIDE SHOWN

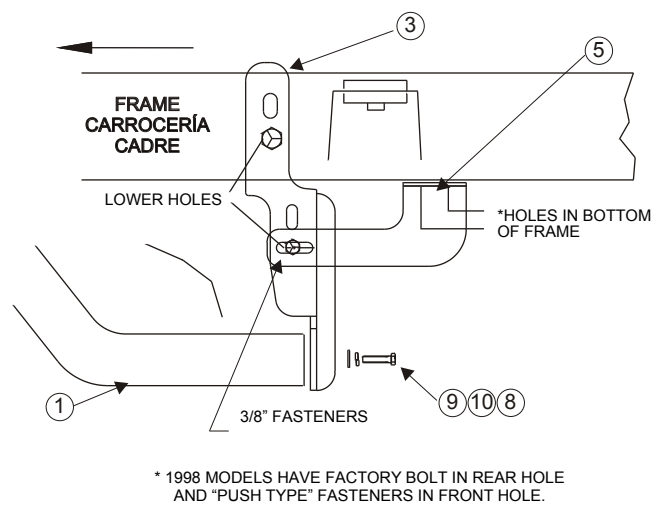

FIGURE 3
DRIVER SIDE

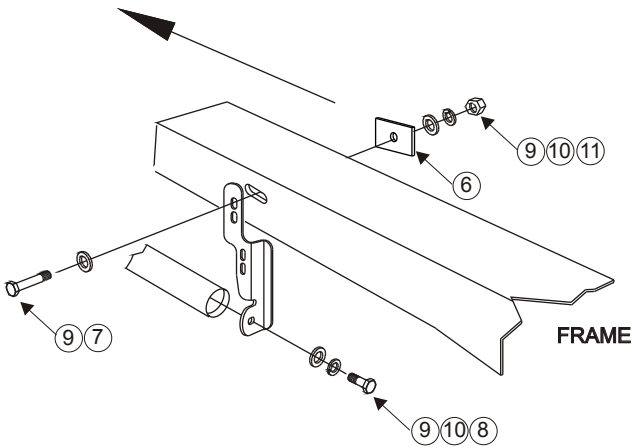
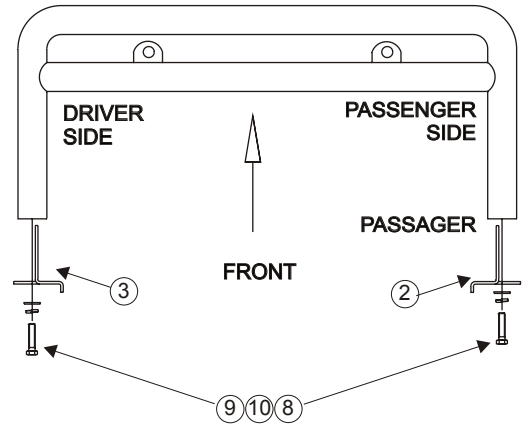

FIGURE 4
TOP VIEW



AUTOMOTIVE PRODUCTS, INC.

Thank You for choosing Westin products.

Shop for quality Westin products on our website.

Buy grille guards and bull bars in our online store.