

# INSTALLATION INSTRUCTIONS

## THRASHER BOARD



**APPLICATION:**  
2019 Chevy Silverado/GMC Sierra 1500 Crew Cab  
**PART NUMBER:**  
28-81275

| CONTENT |          |   |               |
|---------|----------|---|---------------|
| ITEM    | QUANTITY | DESCRIPTION                               | TOOLS NEEDED  |
| 1,2     | 2        | STEP BAR ASSEMBLY (1 DRIVER, 1 PASSENGER) | 10MM SOCKET   |
| 3       | 6        | MOUNTING BRACKET                          | 10MM WRENCH   |
| 4       | 6        | PLASTIC BRACKET COVER                     | 13MM SOCKET   |
| 5       | 6        | M8 BOLT PLATE                             | 13MM WRENCH   |
| 6       | 12       | M8 HEX HEAD CAP SCREW (YELLOW ZINC)       | RATCHET       |
| 7       | 12       | M8 SPLIT LOCK WASHER (YELLOW ZINC)        | TORQUE WRENCH |
| 8       | 12       | M8 FLAT WASHER (YELLOW ZINC)              |               |
| 9       | 12       | M8 SPLIT LOCK WASHER (BLACK ZINC)         |               |
| 10      | 12       | M8 HEX NUT (BLACK ZINC)                   |               |
| 11      | 12       | M8 FLAT WASHER (BLACK ZINC)               |               |
| 12      | 12       | M6 HEX HEAD CAP SCREW (YELLOW ZINC)       |               |
| 13      | 24       | M6 FLAT WASHER (YELLOW ZINC)              |               |
| 14      | 12       | M6 NYLOCK NUT (YELLOW ZINC)               |               |

**ANTI-SEIZE LUBRICANT MUST BE USED ON ALL STAINLESS STEEL FASTENERS TO PREVENT THREAD DAMAGE AND GALLING**

ITEM 2



Driver Side Opposite

ITEM 3

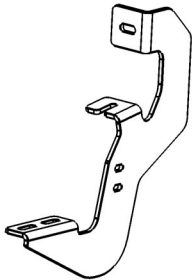

ITEM 4

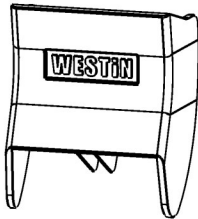

## PROCEDURE

1. Remove contents from box, verify if all parts listed are present and free from damage.  
Carefully read and understand all instructions before attempting installation.  
**Failure to identify damage before installation could lead to a rejection of any claim.**
2. Starting on the driver side, remove the rubber plugs located on the rocker panel at each mounting location. See **Figure 1**.
3. **For models with threaded holes:** At each bracket mounting location on the rocker panel, there should be a welded factory nut.



Figure 1

4. Loosely preinstall the Bracket Covers (4) to the Mounting Brackets using the included M6 Hardware. See **Figure 2**.
5. Partially install the M8 Hardware in the bottom of the rocker panel and then slide the Mounting Brackets (3) into place and install the remaining M8 Hardware. See **Figures 3 & 4**.

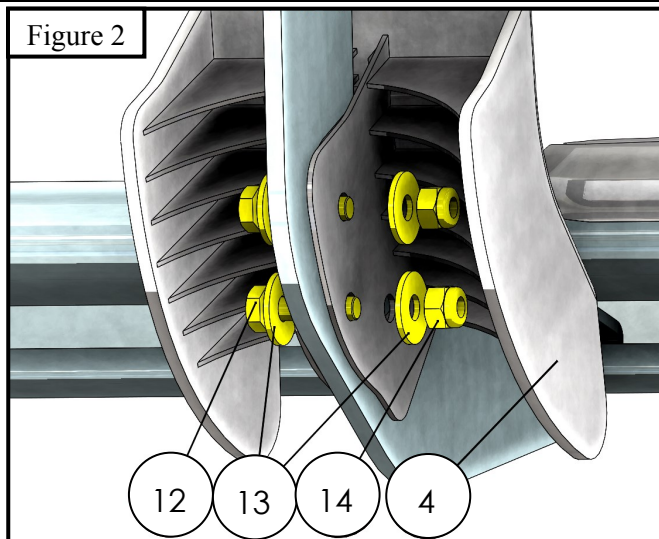

Figure 2

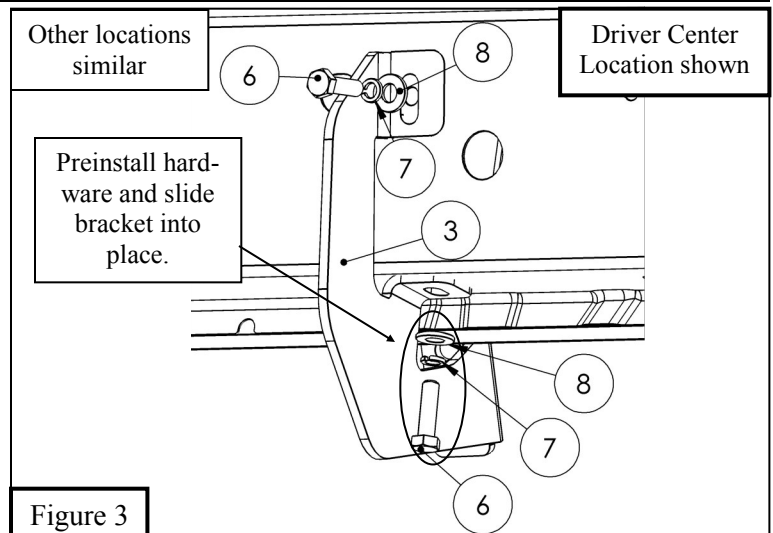

Figure 3

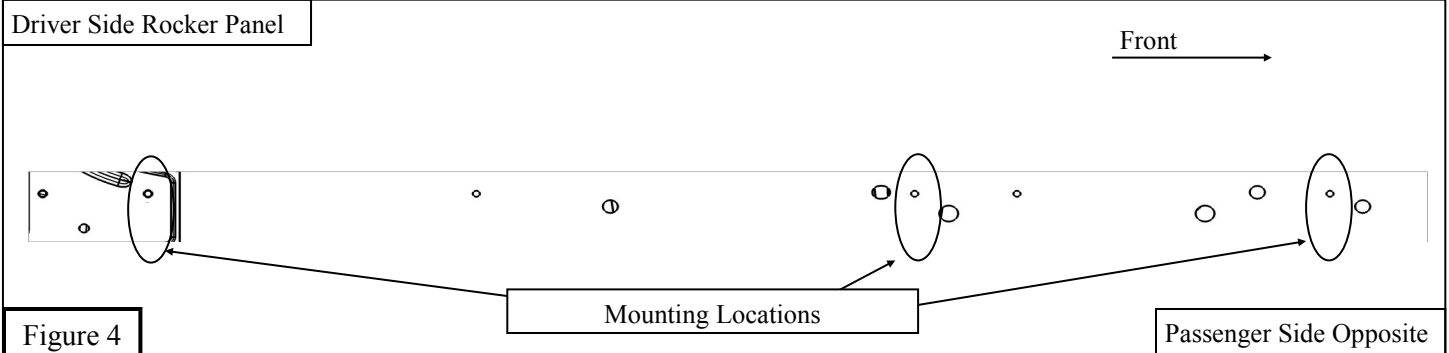
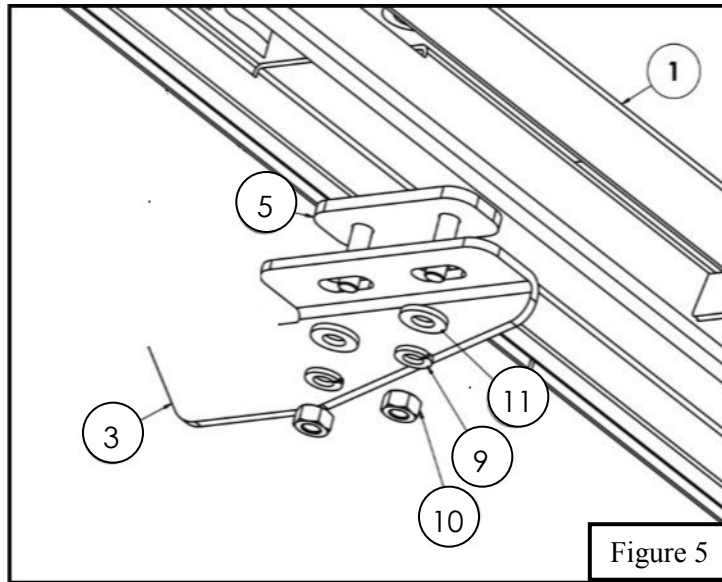

Figure 4

6. For Step Board installation to the previously installed mounting brackets, use the supplied M8 bolt plates and M8 hardware. Slide bolt plate into the board rail located underneath the step board, then loosely install with M8 hardware. **See Figure 5.**



INSTALLATION COMPLETE





## WARNING



Failure to follow these instructions could lead to death, personal injury, and / or property damage.

Failure to follow these instructions could lead to death, personal injury, and / or property damage.

### FASTENERS:

All Westin supplied fasteners must be utilized and installed in accordance with the installation instructions and apply torque to the specifications as defined. **DOUBLE CHECK ALL FASTENERS BEFORE INITIAL USE, AND PERIODICALLY IN THE FUTURE TO ENSURE PROPER FUNCTION AND SAFETY.**

### DRILLING:

Most Westin products do not require drilling for installation. If drilling is defined as required, use caution when drilling a vehicle. **FAILURE TO REVIEW AN AREA TO BE DRILLED MAY RESULT IN PERSONAL INJURY AND/OR INJURY TO OTHERS AS WELL AS VEHICLE DAMAGE.**

### EYE PROTECTION:

**ALWAYS WEAR SAFETY GLASSES OR GOGGLES DURING THE INSTALLATION PROCESS TO AVOID PERSONAL INJURY.**

### MAXIMUM TOWING/CARRYING CAPACITY: (if applicable)

The Westin Receiver Hitches will have a visible tow rating label affixed directly on the product. User should never exceed the vehicle manufacturers maximum tow and weight rating regardless of the capacity of the hitch. **FAILURE TO FOLLOW THESE GUIDELINES WILL VOID THE WESTIN WARRANTY AND MAY RESULT IN PERSONAL INJURY AND/OR INJURY TO OTHERS AS WELL AS VEHICLE DAMAGE.**



[View other grille guards and bull bars made by Westin on our website.](#)