

INSTALLATION INSTRUCTIONS

R7 BOARDS



APPLICATION:
2019 Ford Ranger SuperCrew
PART NUMBER:
28-71290, 28-71295

CONTENT			
ITEM	QUANTITY	DESCRIPTION	TOOLS NEEDED
1	1	DRIVER STEP BAR	10MM SOCKET
2	1	PASSENGER STEP BAR	10MM WRENCH
3	1	DRIVER FRONT BRACKET	13MM SOCKET
4	1	PASSENGER FRONT BRACKET	17MM SOCKET
5	1	DRIVER CENTER BRACKET	RATCHET
6	1	PASSENGER CENTER BRACKET	TORQUE WRENCH
7	1	DRIVER REAR BRACKET	
8	1	PASSENGER REAR BRACKET	
9	6	BRACKET COVER	
10	12	M8 COMBO HARDWARE	
11	12	M10 HEX HEAD BOLT	
12	12	M10 FLAT WASHER	
13	12	M10 SPLIT LOCK WASHER	
14	12	M6 HEX HEAD CAP SCREW	
15	24	M6 FLAT WASHER	
16	12	M6 NYLOCK NUT	

ANTI-SEIZE LUBRICANT MUST BE USED ON ALL STAINLESS STEEL FASTENERS TO PREVENT THREAD DAMAGE AND GALLING



Passenger Side Opposite

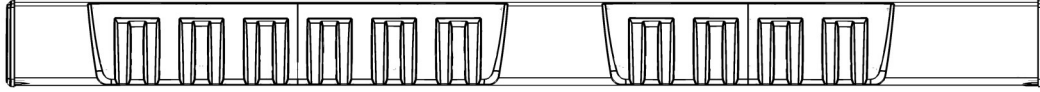

ITEM 1

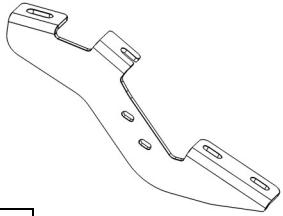

ITEM 3

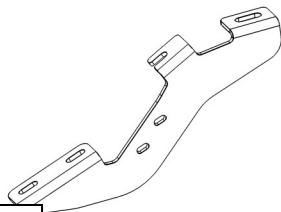

ITEM 4

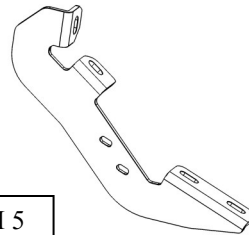

ITEM 5

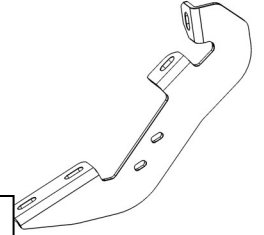

ITEM 6

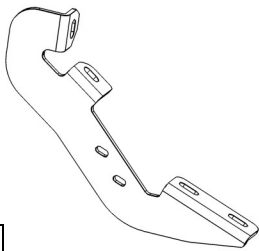

ITEM 7

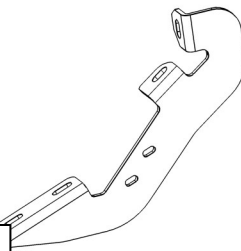

ITEM 8



ITEM 9

PROCEDURE

1. Remove contents from box, verify if all parts listed are present and free from damage.
Carefully read and understand all instructions before attempting installation.
Failure to identify damage before installation could lead to a rejection of any claim.

2. Beginning on the driver side of the vehicle, remove (2) M10 OEM bolts from each mounting location on the rocker panel. See **Figure 1**.

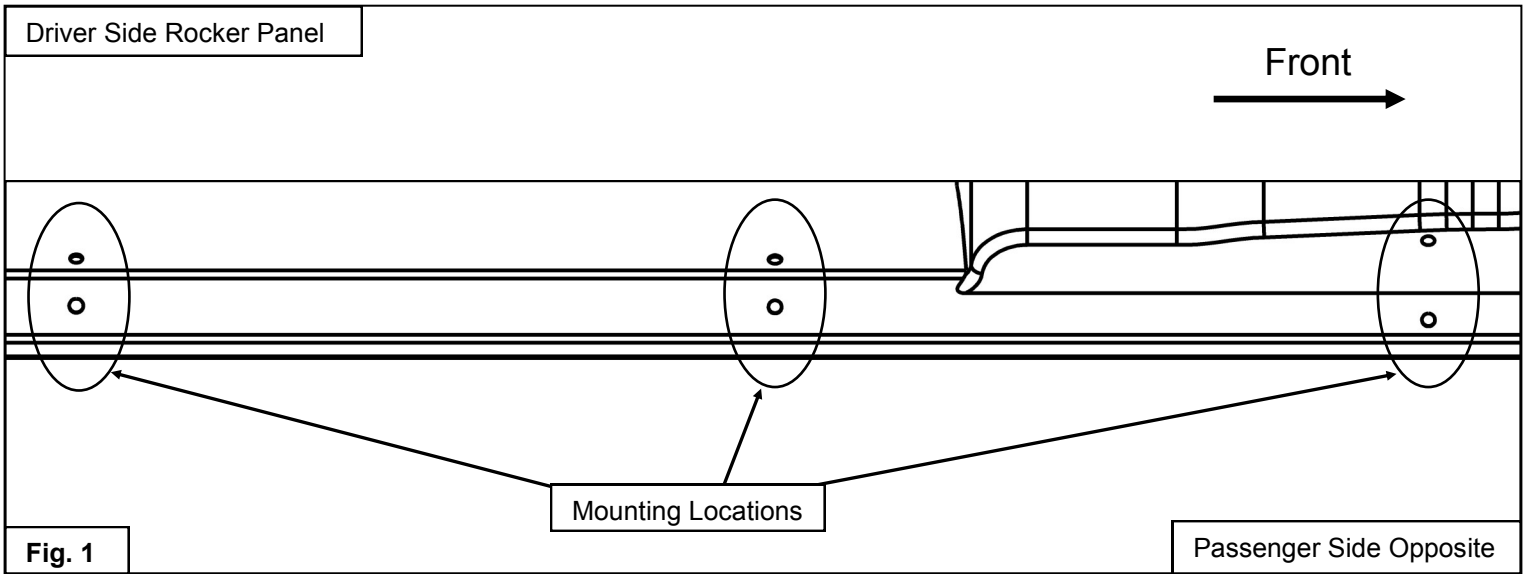

3. Loosely secure (1) Front Mount Bracket (item 3) to the rocker panel using the supplied M10 hardware. See **Figures 1 & 2**.

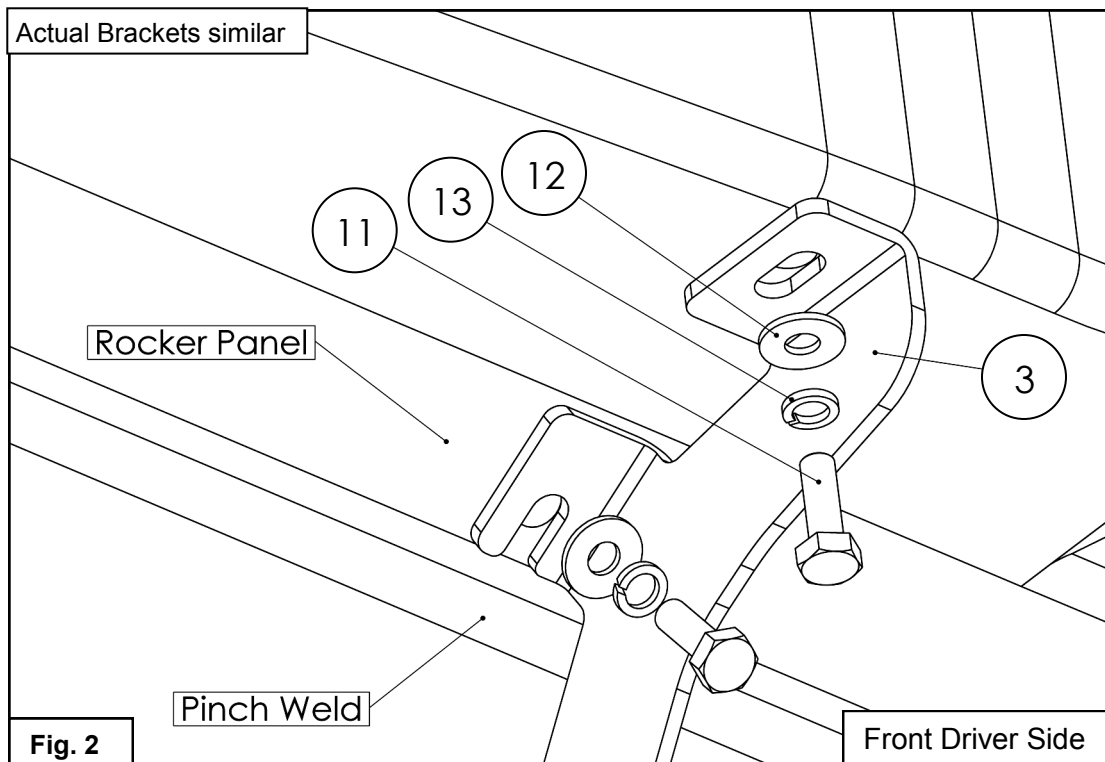

4. Loosely secure (1) Center Mount Bracket (item 5) and (1) Rear Mount Bracket (item 7) to the rocker panel using the supplied M10 hardware. See **Figures 3 & 4**.

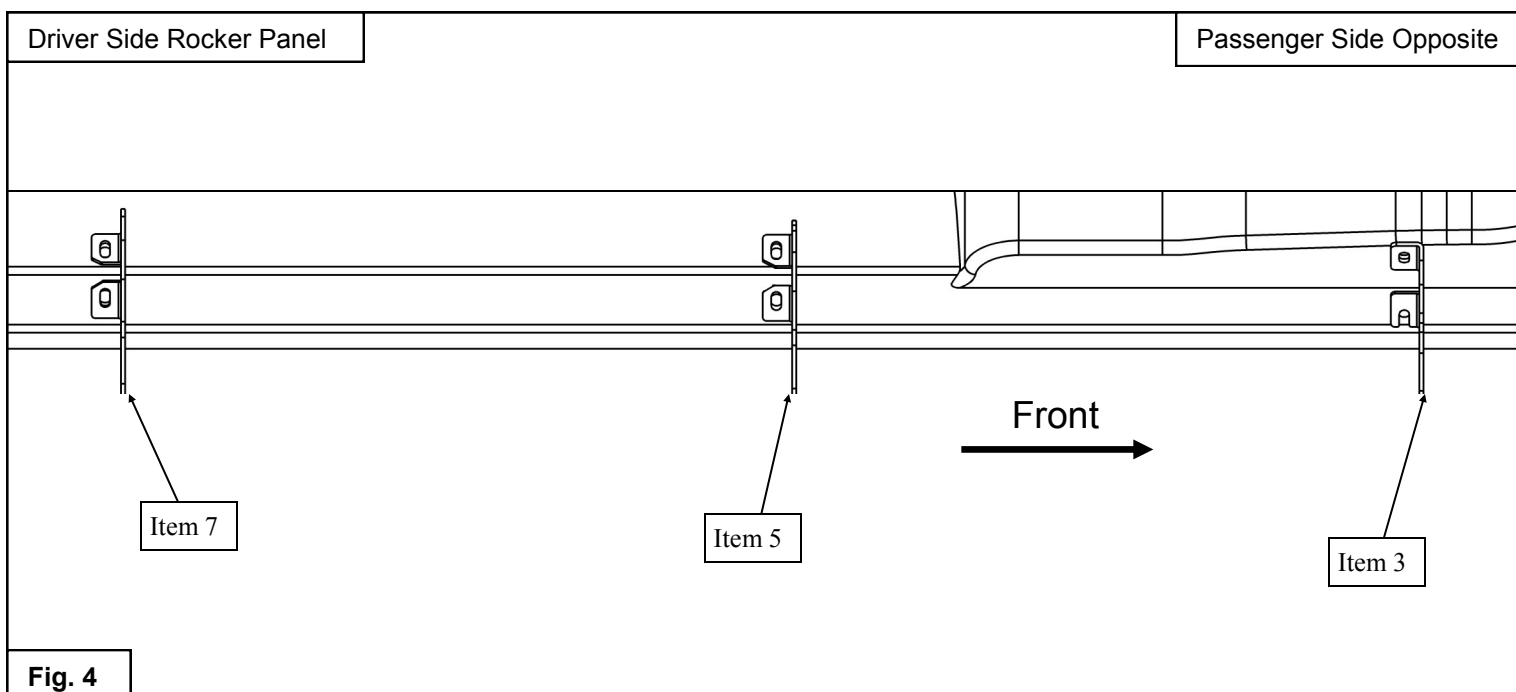
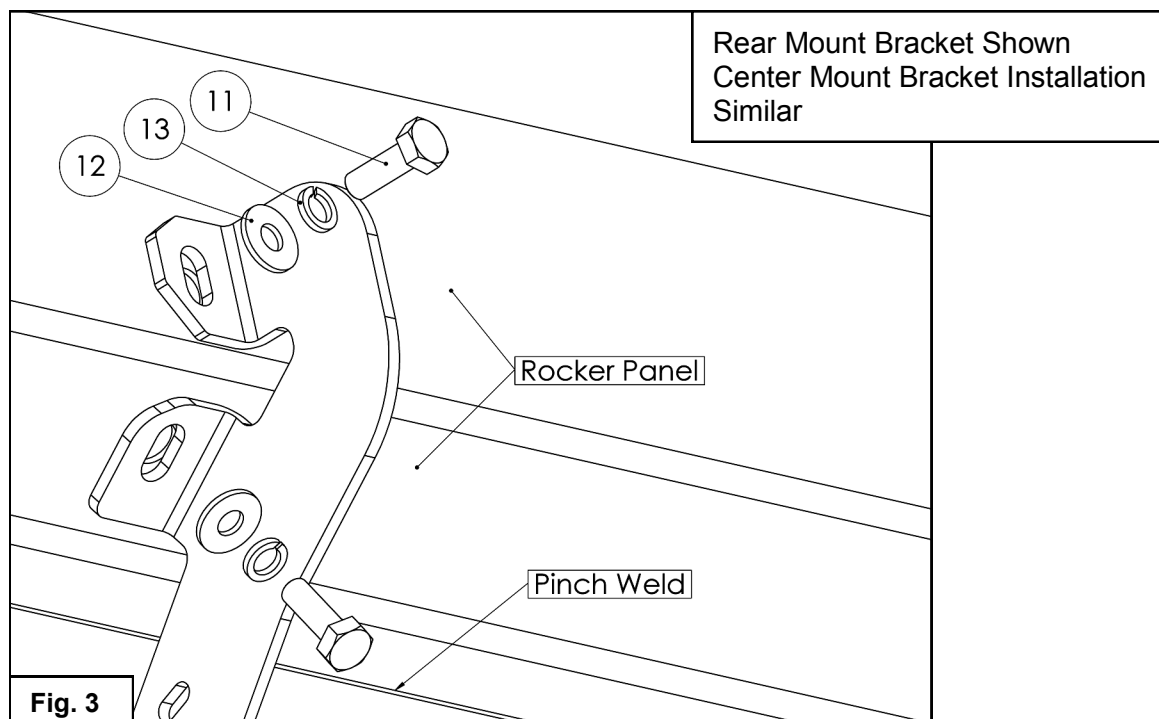

5. Use the supplied M6 Hardware to attach the Bracket Covers (item 9) to the Mounting Brackets (items 3-8). See **Figure 5**.
6. Fasten step bars respectively to either side using the M8 hardware provided with the step bars. See **Figure 6**.
7. Repeat **Steps 2-6** on the passenger side of the vehicle.
8. Adjust brackets and step bars as needed and tighten all hardware as specified: M6 to 7 ft-lbs, M8 to 18 ft-lbs, M10 to 38 ft-lbs.

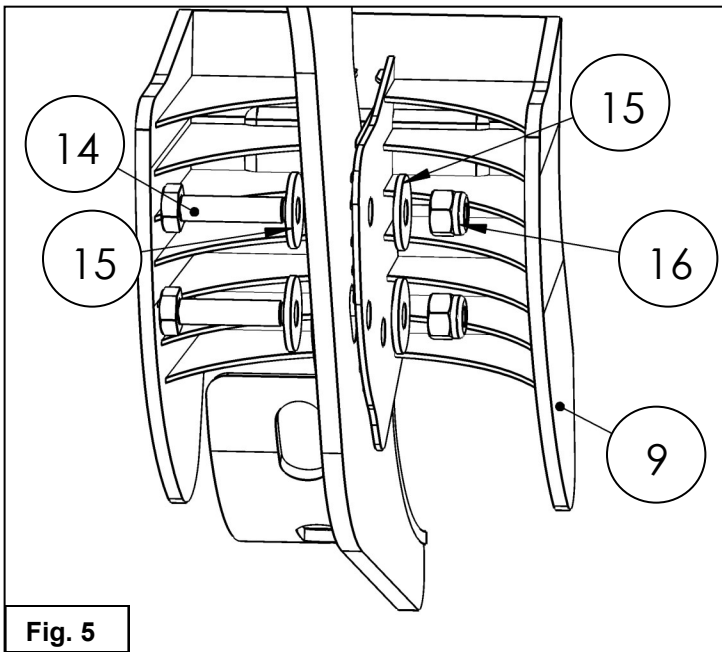

Fig. 5

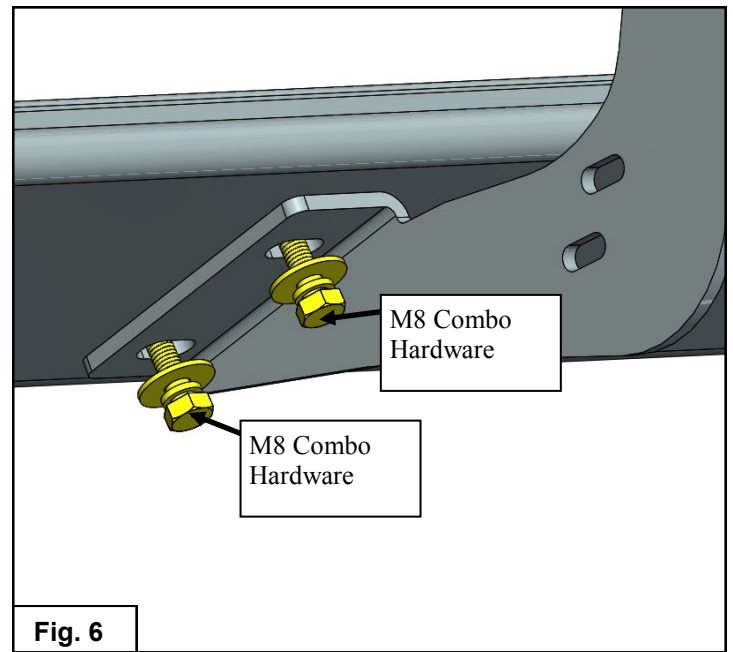

Fig. 6



INSTALLATION COMPLETE

CARE INSTRUCTIONS

- REGULAR WAXING IS RECOMMENDED. DO NOT USE ANY TYPE OF POLISH OR WAX THAT MAY CONTAIN ABRASIVES.
- STAINLESS STEEL PRODUCTS CAN BE CLEANED WITH MILD SOAP AND WATER. STAINLESS STEEL POLISH SHOULD BE USED TO POLISH SMALL SCRATCHES.
- GLOSS BLACK FINISHES SHOULD BE CLEANED WITH MILD SOAP AND WATER



WARNING



Failure to follow these instructions could lead to death, personal injury, and / or property damage.

Failure to follow these instructions could lead to death, personal injury, and / or property damage.

FASTENERS:

All Westin supplied fasteners must be utilized and installed in accordance with the installation instructions and apply torque to the specifications as defined. **DOUBLE CHECK ALL FASTENERS BEFORE INITIAL USE, AND PERIODICALLY IN THE FUTURE TO ENSURE PROPER FUNCTION AND SAFETY.**

DRILLING:

Most Westin products do not require drilling for installation. If drilling is defined as required, use caution when drilling a vehicle. **FAILURE TO REVIEW AN AREA TO BE DRILLED MAY RESULT IN PERSONAL INJURY AND/OR INJURY TO OTHERS AS WELL AS VEHICLE DAMAGE.**

EYE PROTECTION:

ALWAYS WEAR SAFETY GLASSES OR GOGGLES DURING THE INSTALLATION PROCESS TO AVOID PERSONAL INJURY.

MAXIMUM TOWING/CARRYING CAPACITY: (if applicable)

The Westin Receiver Hitches will have a visible tow rating label affixed directly on the product. User should never exceed the vehicle manufacturers maximum tow and weight rating regardless of the capacity of the hitch. **FAILURE TO FOLLOW THESE GUIDELINES WILL VOID THE WESTIN WARRANTY AND MAY RESULT IN PERSONAL INJURY AND/OR INJURY TO OTHERS AS WELL AS VEHICLE DAMAGE.**



Learn more about running boards and step bars we have.