

INSTALLATION INSTRUCTIONS

R5 WHEEL-TO-WHEEL NERF STEP BARS



APPLICATION:
2019-2020 Ram 2500/3500 Crew Cab (6.5 ft bed)
PART NUMBER:
28-534780, 28-534785

CONTENT			
ITEM	QUANTITY	DESCRIPTION	TOOLS NEEDED
1	2	STEP BAR ASSEMBLY FRONT SECTION (1 DRIVER, 1 PASSENGER)	13MM SOCKET
2	2	STEP BAR ASSEMBLY REAR SECTION (1 DRIVER, 1 PASSENGER)	3/8" RATCHET
3	2	STEP PAD	TORQUE WRENCH
4	2	LINK BRACKET (1 DRIVER, 1 PASSENGER)	1/4" RATCHET
5	2	LINK PLATE	10MM SOCKET
6	2	TALL REINFORCEMENT LINK	10MM WRENCH
7	2	SHORT REINFORCEMENT LINK	17MM SOCKET
8	1	MOUNTING BRACKET FRONT PASSENGER	19MM SOCKET
9	1	MOUNTING BRACKET FRONT DRIVER	1/2" RATCHET
10	2	TOP ISOLATOR BRACKET	1/2" EXTENSION
11	2	BOTTOM ISOLATOR BRACKET (1 DRIVER, 1 PASSENGER)	4MM ALLEN
12	2	MOUNTING BRACKET REAR (1 DRIVER, 1 PASSENGER)	DRILL
13	2	ISOLATOR KIT	1/2" DRILL BIT
14	6	PLATE ADAPTER	
15	6	BRACKET COVER	
16	10	BOLT/NUT PLATE	
17	4	M10 FLANGED HEX HEAD BOLT	
18	10	M10 SPLIT LOCK WASHER	
19	10	M10 FLAT WASHER	
20	10	M10 HEX NUT	
21	12	M8 HEX HEAD CAP SCREW	
22	24	M8 SPLIT LOCK WASHER (12x Yellow Zinc, 12x Black Zinc)	
23	24	M8 FLAT WASHER (12x Yellow Zinc, 12x Black Zinc)	
24	12	M8 HEX NUT	
25	24	M6 HEX HEAD CAP SCREW (12x Yellow Zinc, 12x Black Zinc)	
26	6	M6 BUTTON HEAD SCREW	
27	12	LARGE M6 FLAT WASHER	
28	24	MEDIUM M6 FLAT WASHER	

ANTI-SEIZE LUBRICANT MUST BE USED ON ALL STAINLESS STEEL FASTENERS TO PREVENT THREAD DAMAGE AND GALLING



CONTENT			
ITEM	QUANTITY	DESCRIPTION	TOOLS NEEDED
29	6	SMALL M6 FLAT WASHER	
30	12	M6 SPLIT LOCK WASHER	
31	12	M6 NYLOCK NUT	
32	6	M6 SERRATED FLANGE NUT	
33	8	M8 RIV-CERT	
34	5	M10 PLASTIC RETAINER	
35	4	M10 FISH WIRE	
36	16	THREAD CUTTING NUTS	

ANTI-SEIZE LUBRICANT MUST BE USED ON ALL STAINLESS STEEL FASTENERS TO PREVENT THREAD DAMAGE AND GALLING

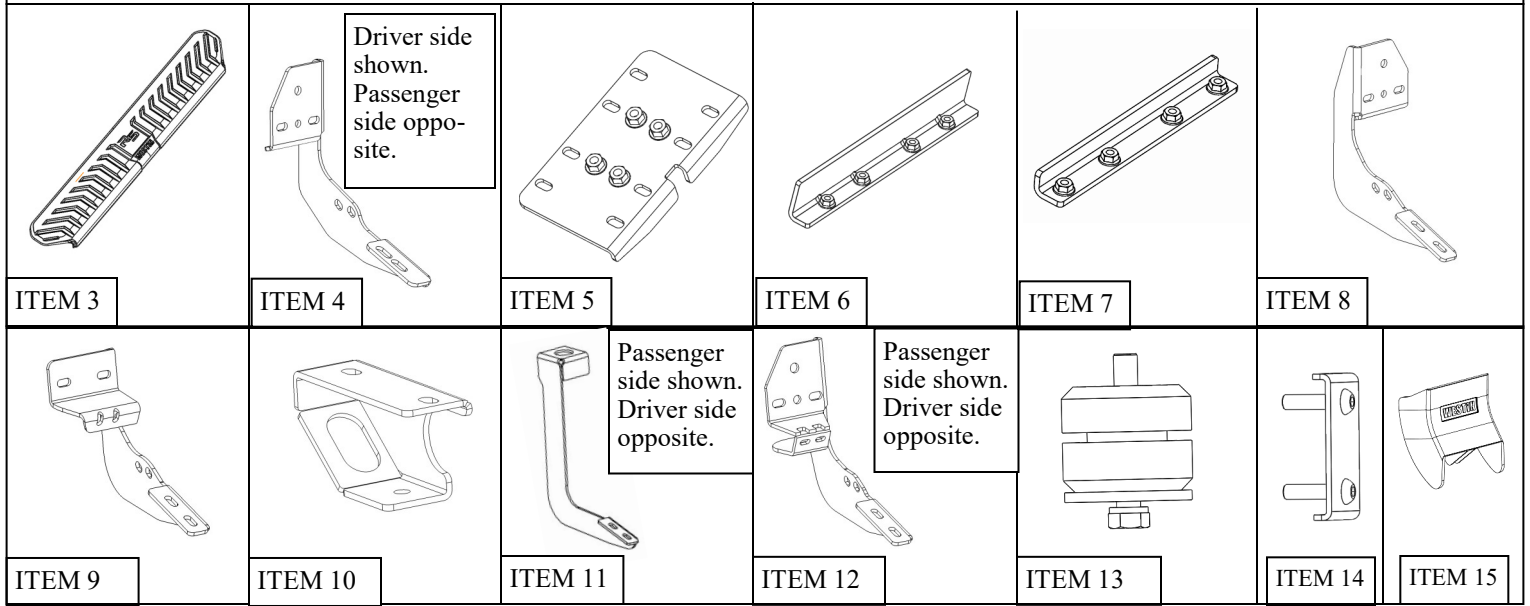
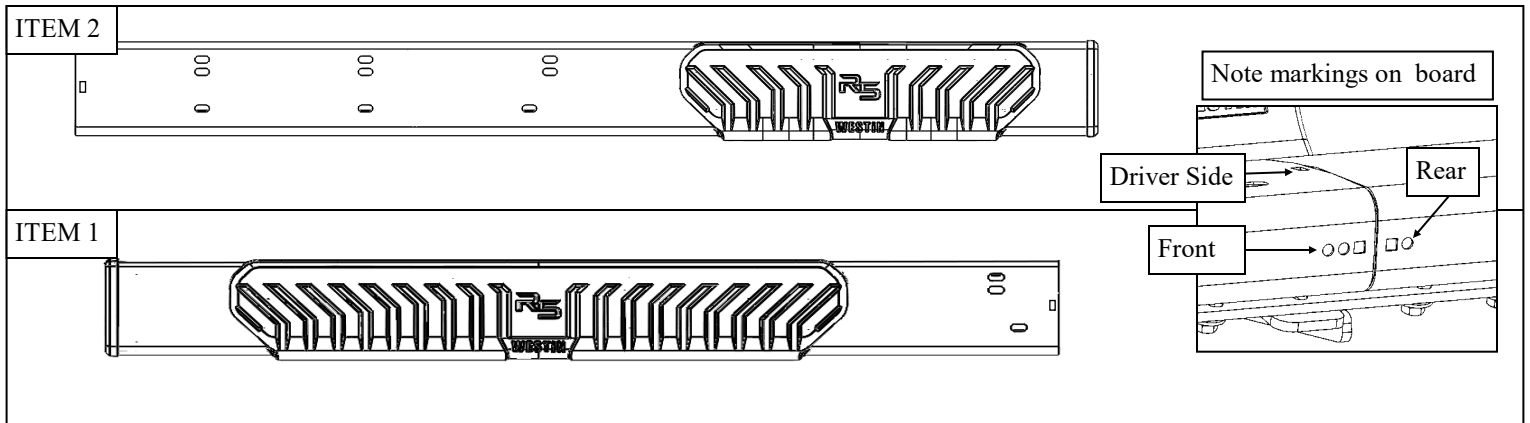

PROCEDURE

1. Remove contents from box, verify if all parts listed are present and free from damage. Carefully read and understand all instructions before attempting installation.
Failure to identify damage before installation could lead to a rejection of any claim.

2. Check either side of the vehicles rocker panel, locate the factory holes in the rocker panel by removing the tape. Check and verify what type of rocker panel you have. See **Figures 1, 2, 3, & 4**. **Note:** If any of the locations on the factory holes in the rocker panel have factory M8 Riv-Certs or threaded M8 holes, do not use provided M8 Riv-Certs (Item 33) at that location. Refer to **Figures 1, 2, & 4**.

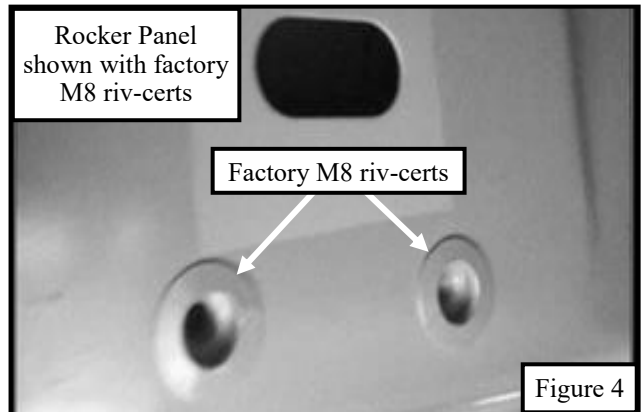
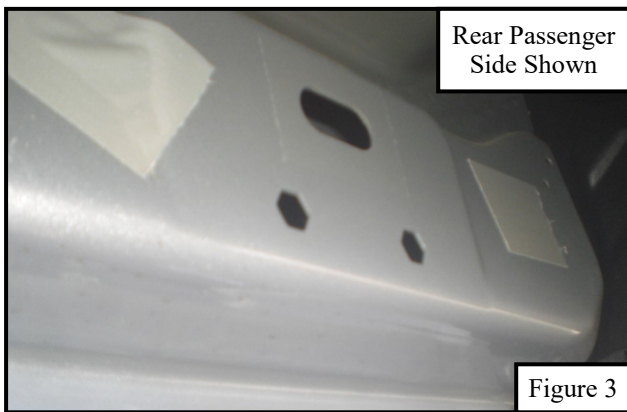
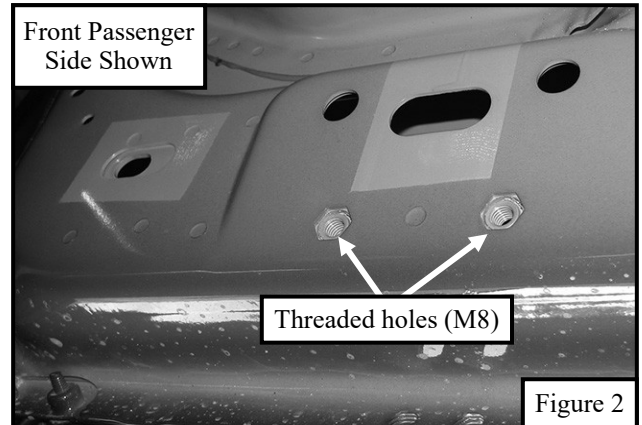
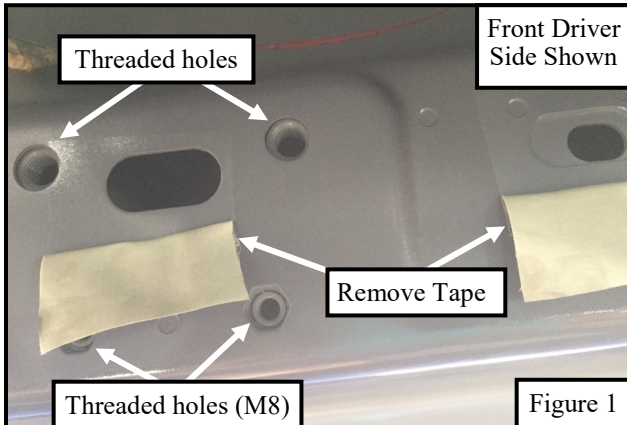

3. **Starting from the driver side:** If the threaded holes or threaded holes are not present use (1) M8 riv-certs (Item 33) and insert one into the either hex hole. Insert (1) M10 bolt / M8 nut plate (Item 16) and secure using (1) plastic retainer square (Item 34). See **Figure 5**. **Note:** See **Figure 6** for example on how to tighten M8 riv-certs, it will require to use an M10 bolt with M8 nut plate (Item 16) along with a bracket to perform this task. This procedure will permanently install M8 riv-cert. Repeat **step 3** for every bracket, except for the isolator bracket.

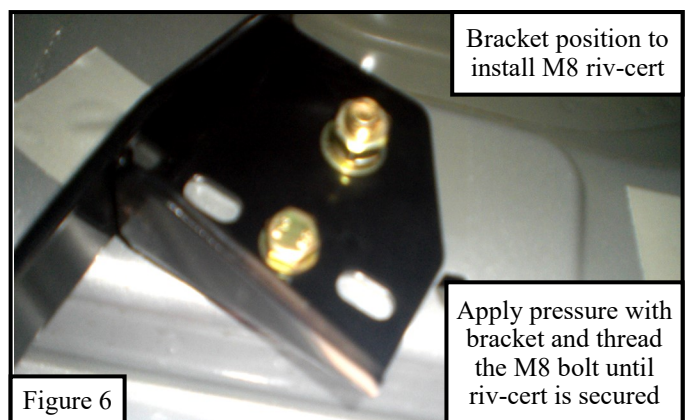
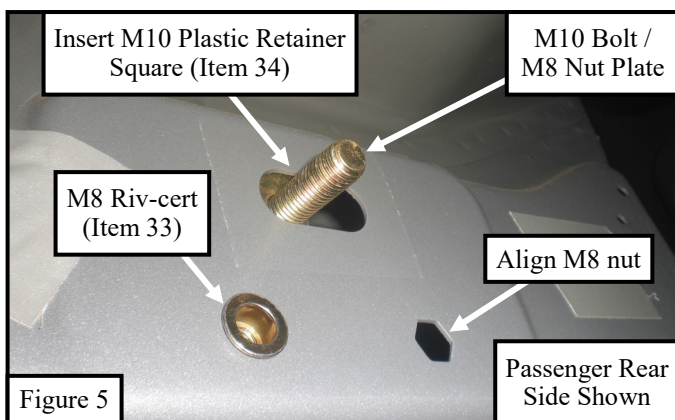

FOR NEWER MODELS: If the rocker panel has pre-installed M8 Riv-Certs or threaded holes, the M10 bolt / M8 nut plate will need to be positioned as shown in **Figure 8**.

FOR OLDER MODELS: If the rocker panel does not have pre-installed M8 Riv-Certs or threaded holes then will be used as shown on **Figures 5 & 11**.

- Proceed to install Mounting Bracket **Item 8** and Mounting Bracket **Item 12** onto the rocker panel by using (2) M8 hex cap screws, (2) M8 lock washers, (2) M8 flat washers. For the pinch weld, attach bracket by using the provided black zinc M6 hardware. See **Figures 9, 10, and 12**.

Note: Drilling of two 1/4" holes might be necessary on pinch weld if factory holes are not present. Before drilling place masking tape on drill surface to prevent paint chipping.

- Loosely secure the Link Bracket **Item 4** to the rocker panel in the center mounting locations and **Item 8** to front passenger location using (2) M8 hex bolts, (2) M8 lock washers, (2) M8 flat washers, (1) M10 flat washer, (1) M10 lock washer, and (1) M10 hex nut. Leave everything loose at this time. See **Figures 7 & 11**.

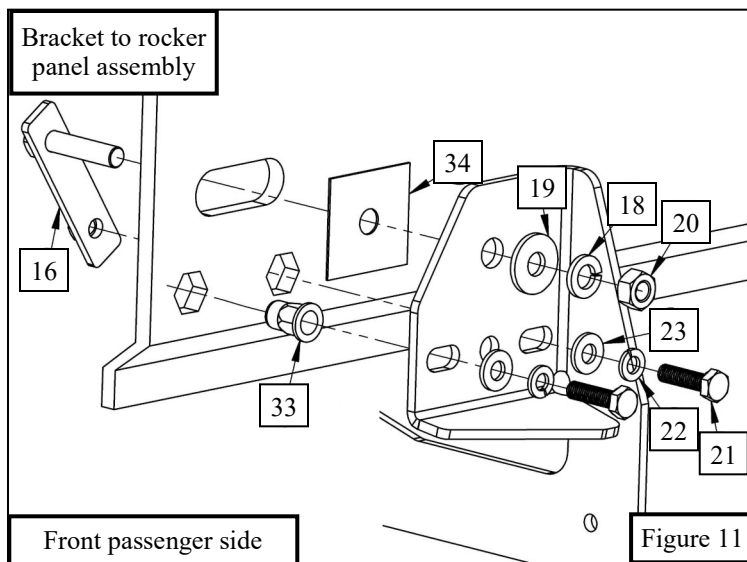
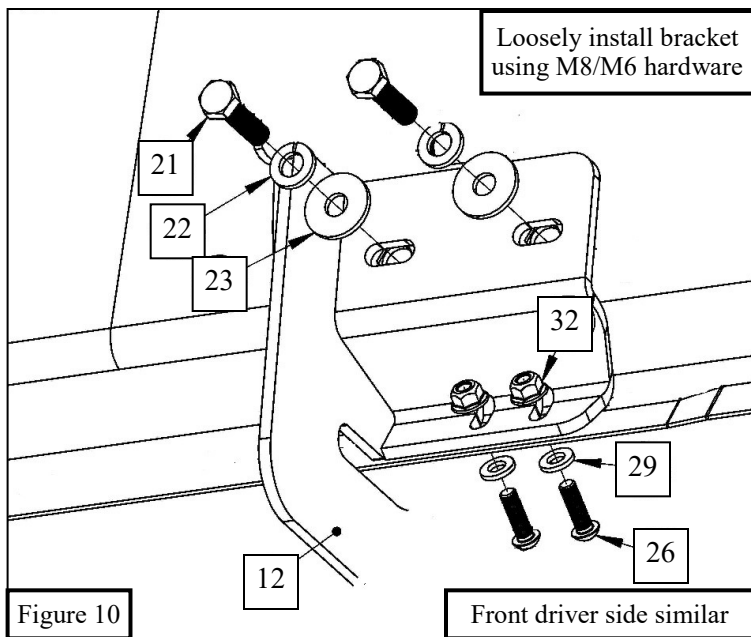
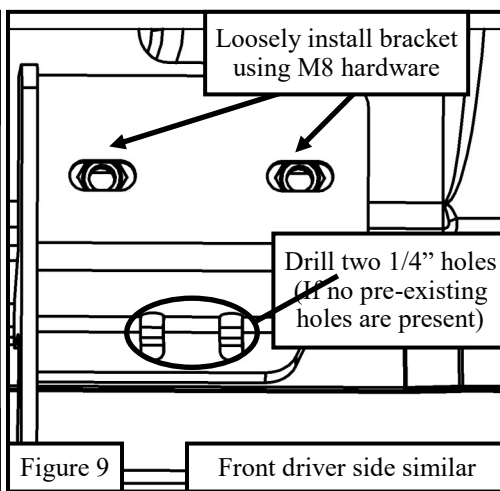
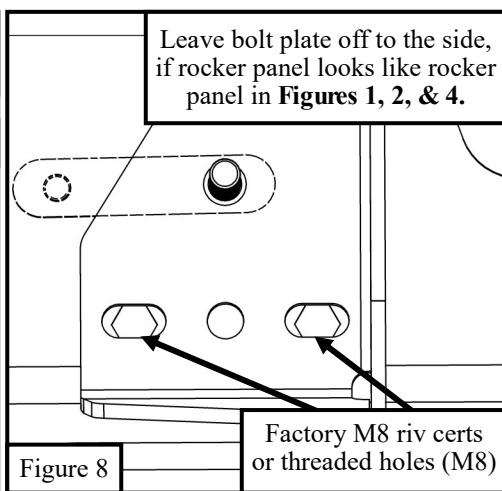
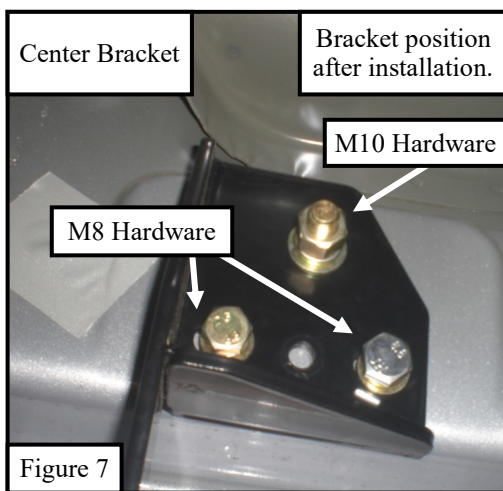

- On either side of the vehicle, directly behind the cab, underneath the bed locate the bed rail. Grab the Drill Template and align it with the bed rail and the thin bed wall. Use a center drill bit to start the 2 holes. Then drill out 2 (1/2") holes using a 1/2" drill bit. Repeat on opposite side with the opposite side drill template. See **Figure 13**.

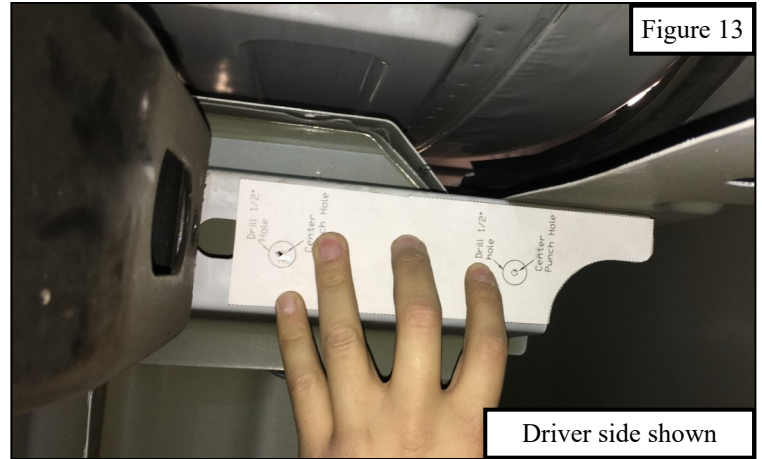
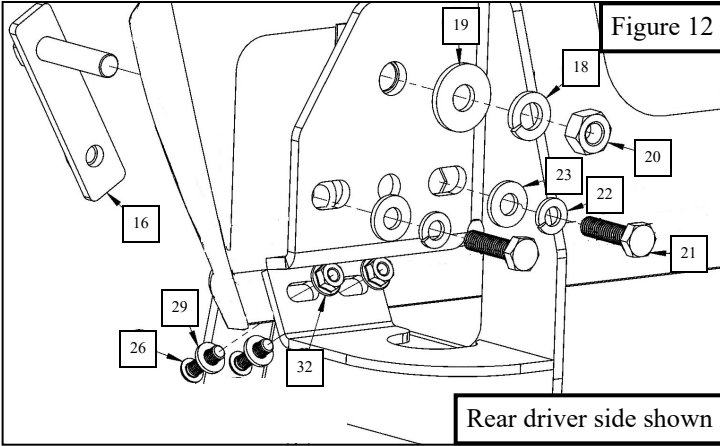

- Locate (1) M10 fish wire (Item 35) and fish (1) M10 bolt / M8 nut plate (Item 16) through the rear drilled hole. Once both bolt plates are placed, loosely install the Top Isolator Bracket (Item 10) with the supplied M10 hardware. See **Figure 14**.
- Locate (1) isolator kit (Item 12) and (1) isolator bracket (9/10) and loosely secure each other with the top isolator bracket. See **Figure 15**. (**Note:** See bracket orientation below and on pg.6)

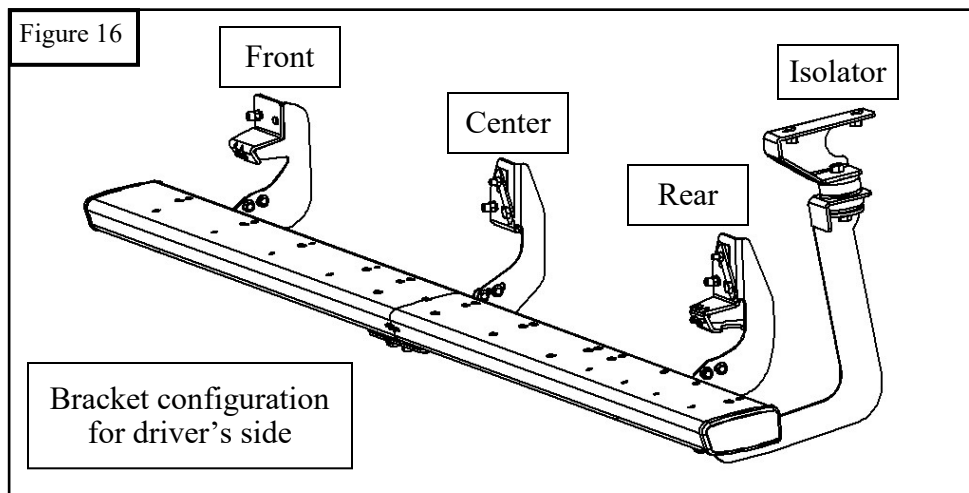
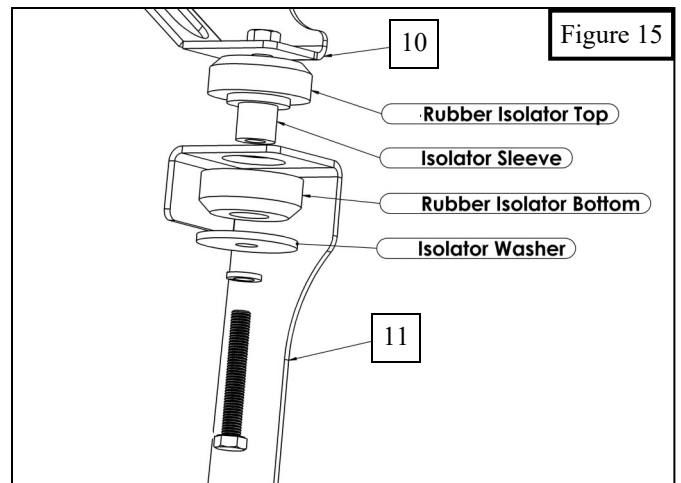
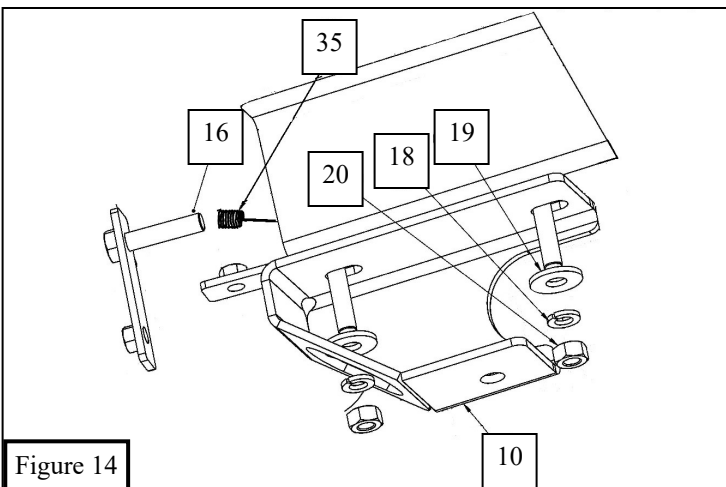
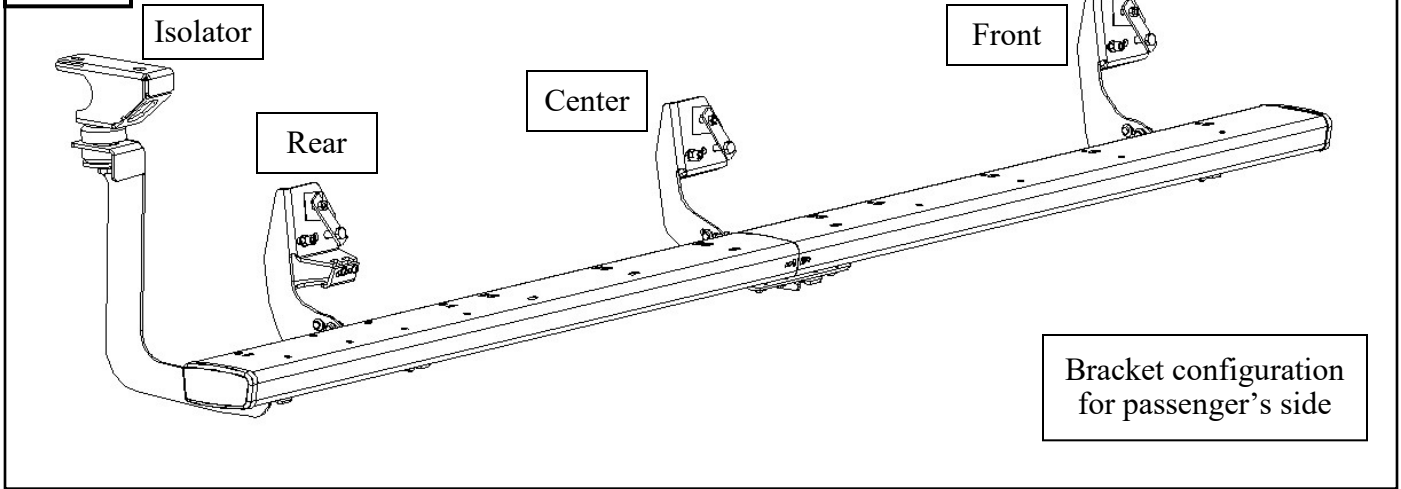

Figure 17



10. Obtain both sections of the Step Bar Assembly (1 or 2). Slide the Reinforcement Links (6 & 7) into both sides of the step bar sections. See Figure 18.

Line up the holes on the Step Bar sections with the holes on the Reinforcement Links (4 & 7). See Figure 19.

Figure 18



Figure 19

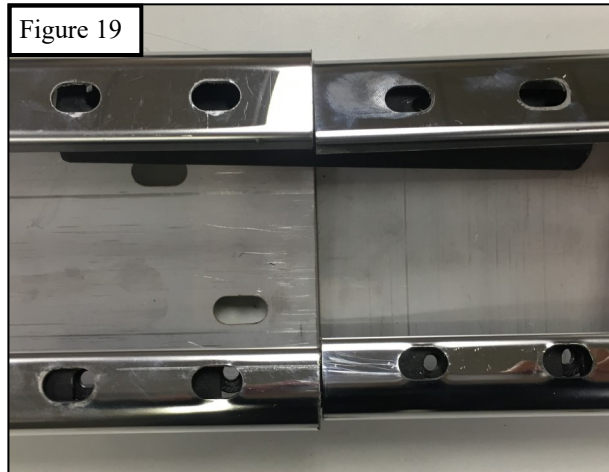

13. Place the supplied step pad into the holes to connect the two Step Bar sections (1 & 2). Place the supplied thread cutting nut on each of the plastic stems. See Figures 20 and 21.

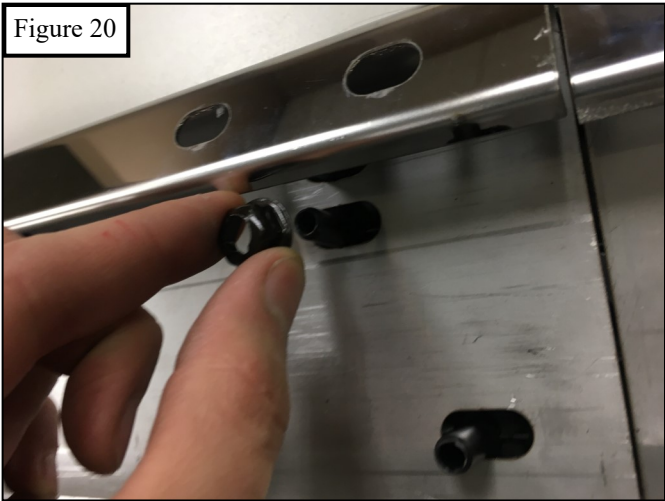

14. Obtain the Link Plate (5) and secure it to the Step Bar Assembly (1 & 2) using the supplied M6 Hardware. See Figure 22.

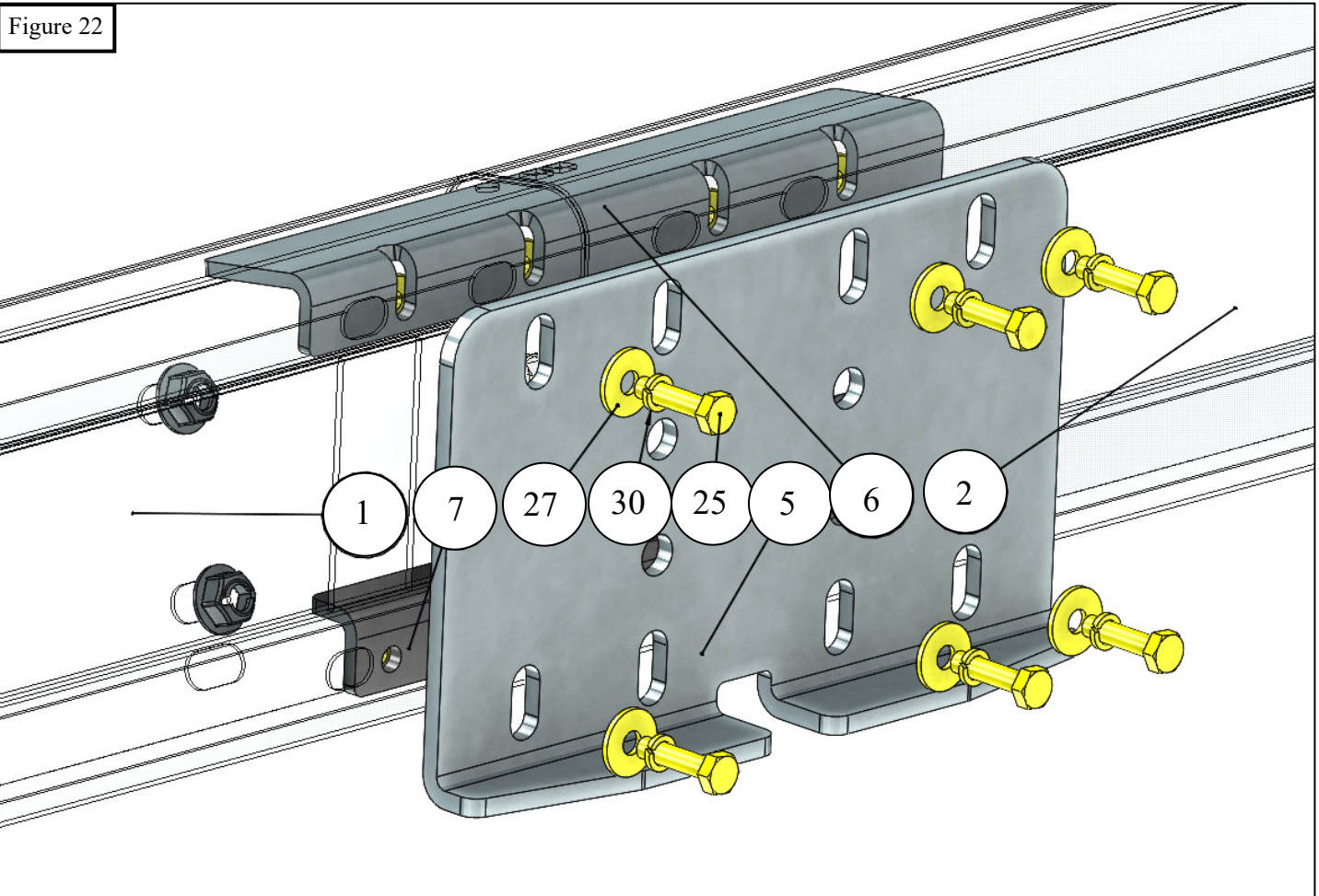

15. Installation of the step boards will utilize the supplied M8 hardware with Plate Adapters (14) for all brackets excluding the Link Brackets (4). The Link Brackets (4) will use the supplied M10 hardware. **See Figures 23 and 24.**

16. To minimize gap between step bars, and for a better fit of step pad around step bar. Make sure to align and adjust the step bars and brackets as needed, then fully tighten all hardware: M6 to 5 to 7 ft-lbs, M8 to 15-18 ft-lbs, M10 to 32-38 ft-lbs, and M12 to 52-60 ft-lbs.

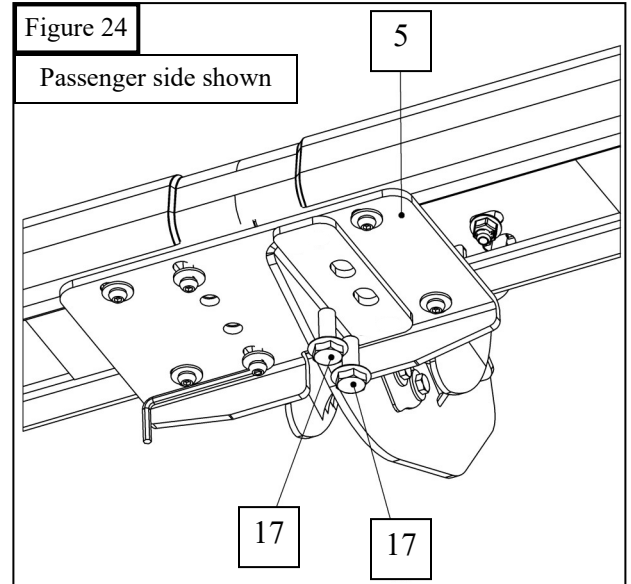
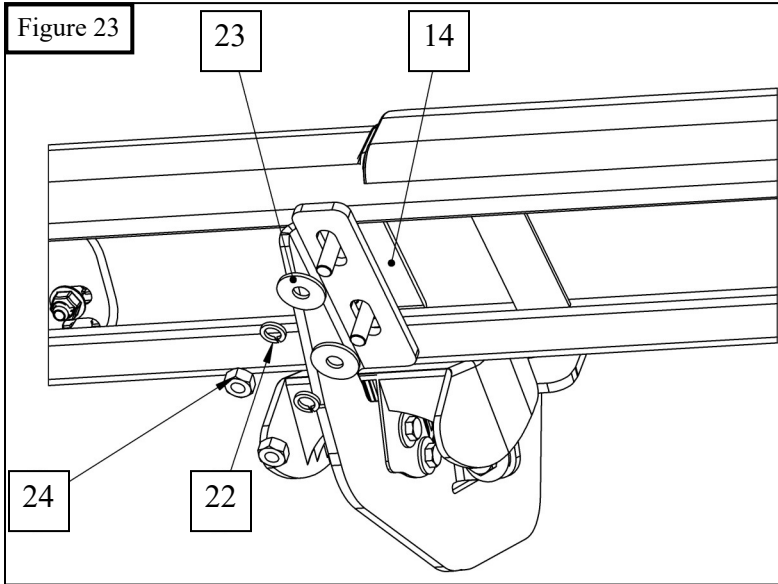

FOR LINK BRACKETS ONLY

17. Use supplied M6 hardware following the configuration shown in **Figure 25** to install plastic bracket covers. Tighten until bracket cover stays sturdy in desired position.

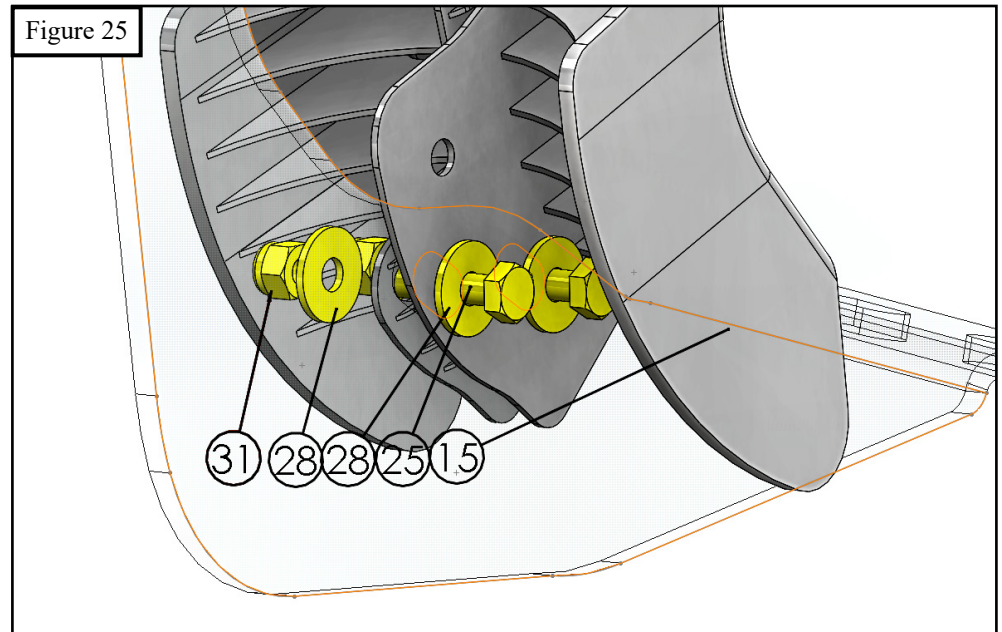

INSTALLATION COMPLETE



CARE INSTRUCTIONS

- REGULAR WAXING IS RECOMMENDED. DO NOT USE ANY TYPE OF POLISH OR WAX THAT MAY CONTAIN ABRASIVES.
- STAINLESS STEEL PRODUCTS CAN BE CLEANED WITH MILD SOAP AND WATER. STAINLESS STEEL POLISH SHOULD BE USED TO POLISH SMALL SCRATCHES.
- GLOSS BLACK FINISHES SHOULD BE CLEANED WITH MILD SOAP AND WATER.



WARNING



Failure to follow these instructions could lead to death, personal injury, and / or property damage.

Failure to follow these instructions could lead to death, personal injury, and / or property damage.

FASTENERS:

All Westin supplied fasteners must be utilized and installed in accordance with the installation instructions and apply torque to the specifications as defined. **DOUBLE CHECK ALL FASTENERS BEFORE INITIAL USE, AND PERIODICALLY IN THE FUTURE TO ENSURE PROPER FUNCTION AND SAFETY.**

DRILLING:

Most Westin products do not require drilling for installation. If drilling is defined as required, use caution when drilling a vehicle. **FAILURE TO REVIEW AN AREA TO BE DRILLED MAY RESULT IN PERSONAL INJURY AND/OR INJURY TO OTHERS AS WELL AS VEHICLE DAMAGE.**

EYE PROTECTION:

ALWAYS WEAR SAFETY GLASSES OR GOGGLES DURING THE INSTALLATION PROCESS TO AVOID PERSONAL INJURY.

MAXIMUM TOWING/CARRYING CAPACITY: (if applicable)

The Westin Receiver Hitches will have a visible tow rating label affixed directly on the product. User should never exceed the vehicle manufacturers maximum tow and weight rating regardless of the capacity of the hitch. **FAILURE TO FOLLOW THESE GUIDELINES WILL VOID THE WESTIN WARRANTY AND MAY RESULT IN PERSONAL INJURY AND/OR INJURY TO OTHERS AS WELL AS VEHICLE DAMAGE.**

FOR CALIFORNIA RESIDENTS ONLY-PROP 65 WARNING:

Some products may contain chemicals such as DEHP, which can cause cancer, birth defects or other reproductive harm.