

INSTALLATION INSTRUCTIONS

R5 WHEEL TO WHEEL NERF STEP BARS



APPLICATION:

2019 Ram 1500 Crew Cab 5'7" Bed

PART NUMBER:

28-534700, 28-534705





CONTENT			
ITEM	QUANTITY	DESCRIPTION	TOOLS NEEDED
1	2	STEP BAR ASSEMBLY FRONT SECTION (1 DRIVER, 1 PASSENGER)	16MM SOCKET
2	2	STEP BAR ASSEMBLY REAR SECTION (1 DRIVER, 1 PASSENGER)	16MM WRENCH
3	2	STEP PAD	13MM SOCKET
4	2	LINK BRACKET (1 DRIVER, 1 PASSENGER)	13MM WRENCH
5	2	LINK PLATE	10MM SOCKET
6	2	TALL REINFORCEMENT LINK	10MM WRENCH
7	2	SHORT REINFORCEMENT LINK	15MM SOCKET
8	3	MOUNTING BRACKET A	1/2" EXTENSION
9	1	MOUNTING BRACKET B	RATCHET
10	2	TOP ISOLATOR BRACKET (1 DRIVER, 1 PASSENGER)	TORQUE WRENCH
11	2	TOP ISOLATOR BRACE (1 DRIVER, 1 PASSENGER)	IMPACT GUN
12	2	BOTTOM ISOLATOR BRACKET (1 DRIVER, 1 PASSENGER)	BREAKER BAR
13	6	MOUNTING BRACKET BASE	
14	4	ISOLATOR KIT	
15	8	PLASTIC BRACKET COVER	
16	6	PLATE ADAPTER	
17	2	M10 FLANGED HEX HEAD BOLT (YELLOW ZINC)	
18	4	M10 FLANGED HEX HEAD BOLT (BLACK ZINC)	
19	4	M10 FLAT WASHER	
20	2	M10 HEX NUT	
21	24	M8 SPLIT LOCK WASHER (YELLOW ZINC)	
22	24	M8 FLAT WASHER (YELLOW ZINC)	
23	24	M8 HEX NUT (YELLOW ZINC)	
24	6	M8 SQUARE NECK BOLT (BLACK ZINC)	
25	12	M8 SPLIT LOCK WASHER (BLACK ZINC)	
26	12	M8 FLAT WASHER (BLACK ZINC)	
27	12	M8 HEX NUT (BLACK ZINC)	
28	16	M6 HEX HEAD CAP SCREW (YELLOW ZINC)	
29	32	M6 FLAT WASHER (YELLOW ZINC)	

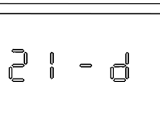
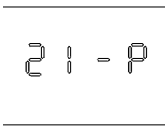
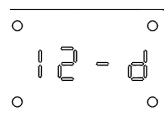
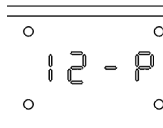

CONTENT

ITEM	QUANTITY	DESCRIPTION	TOOLS NEEDED
30	16	M6 NYLOCK NUT (YELLOW ZINC)	
31	12	M6 HEX HEAD CAP SCREW (BLACK ZINC)	
32	12	M6 FLAT WASHER (BLACK ZINC)	
33	12	M6 SPLIT LOCK WASHER (BLACK ZINC)	
34	18	PLASTIC RETAINER SQUARE	

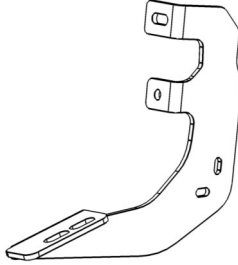
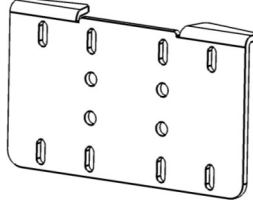
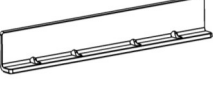
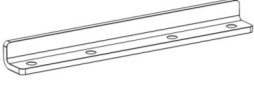
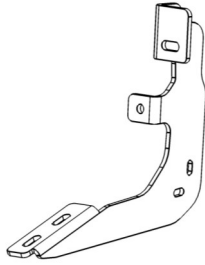
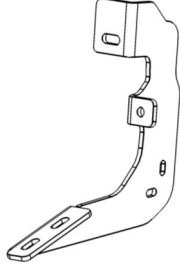
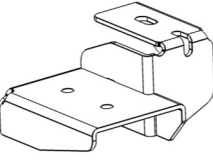
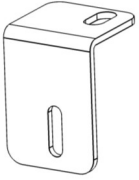
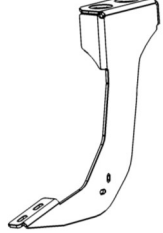
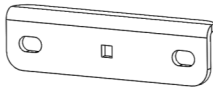
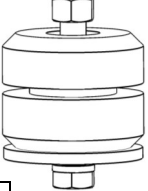
ANTI-SEIZE LUBRICANT MUST BE USED ON ALL STAINLESS STEEL FASTENERS TO PREVENT THREAD DAMAGE AND GALLING

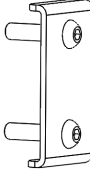
							
ITEM 1	Driver Side Front Marking	Passenger Side Front Marking	ITEM 2	Driver Side Rear Marking	Passenger Side Rear Marking		
							
ITEM 3			ITEM 4				
							
ITEM 6	ITEM 7			ITEM 8			
							
ITEM 10	ITEM 11			ITEM 12			
						<p>DRIVER SIDE ITEMS SHOWN PASSENGER SIDE OPPOSITE WHEN APPLICABLE</p>	
ITEM 14	ITEM 15			ITEM 16			

PROCEDURE

1. Remove contents from box, verify if all parts listed are present and free from damage.

Carefully read and understand all instructions before attempting installation.

Failure to identify damage before installation could lead to a rejection of any claim.

2. Preassemble the Mounting Brackets and Link Brackets (4,8,9). Do not tighten hardware at this time. See **Figure 1**.

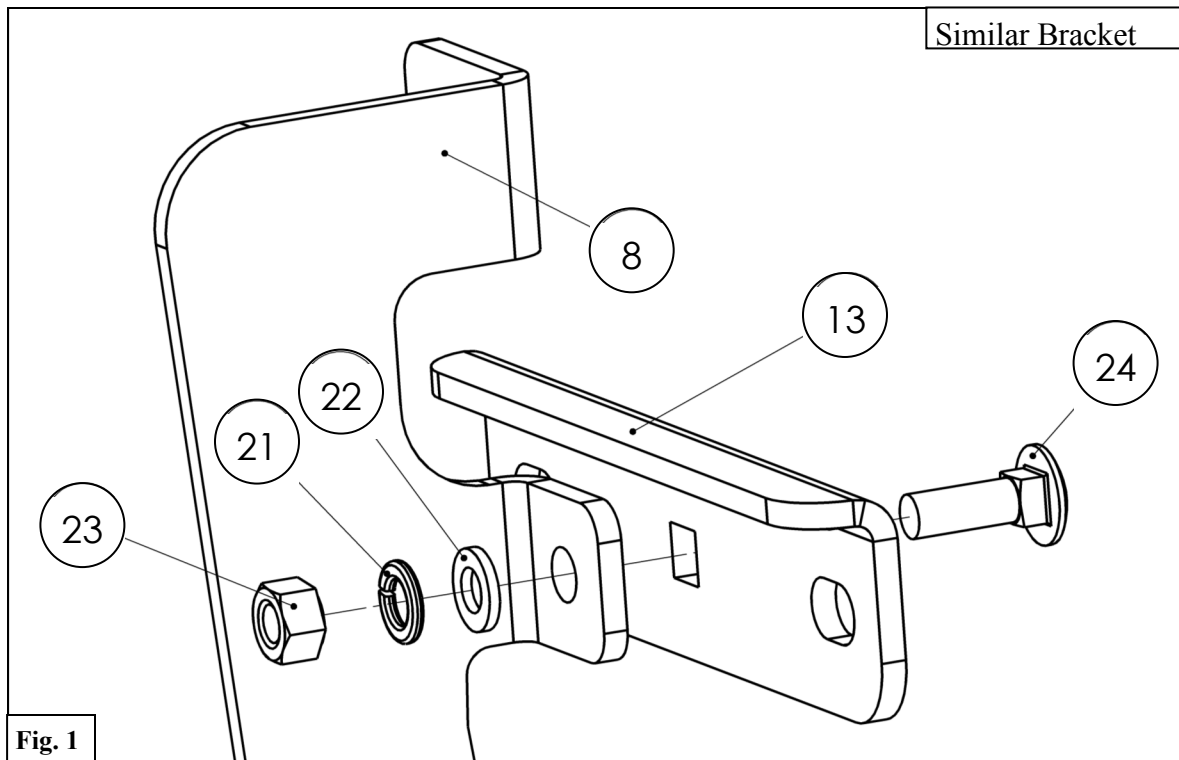

3. Starting on the passenger side of the vehicle, locate the 3 mounting locations on the rocker panel.

Note A: The rear mounting location is shown in **Figure 2**. Other mounting locations are similar.

Note B: The lower two studs on the rocker panel have a thick coat of paint on them. When installing the M8 hex nuts, apply extra pressure to start. If necessary, back M8 hex nuts off the studs to clear build up.

See **Figure 2**.

Note C: You may install plastic retainer squares (Item 34) on each stud before installing bracket as insulation between the bracket and rocker panel.

Rear Mounting Location Shown
Other Mounting Locations are Similar

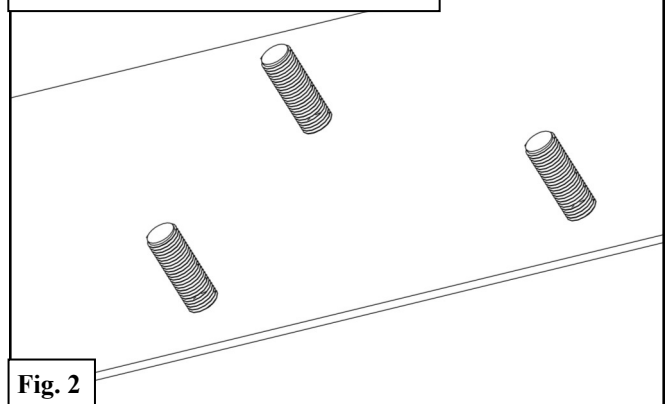

4. At the rear mounting location, loosely install Mounting Bracket A (8) with preassembled Mounting Bracket Base (13) using the supplied M8 hardware. See **Figures 3 & 4**.

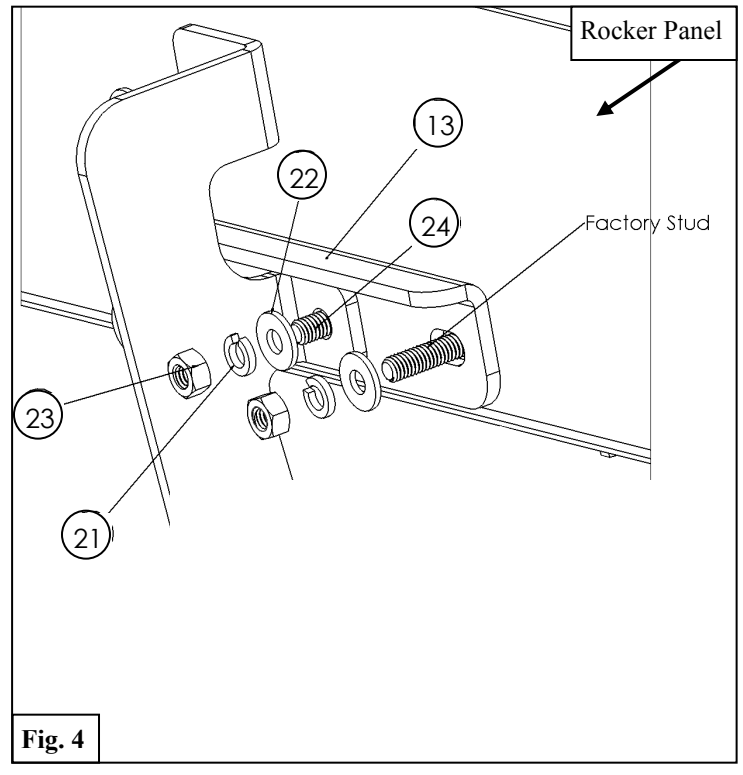
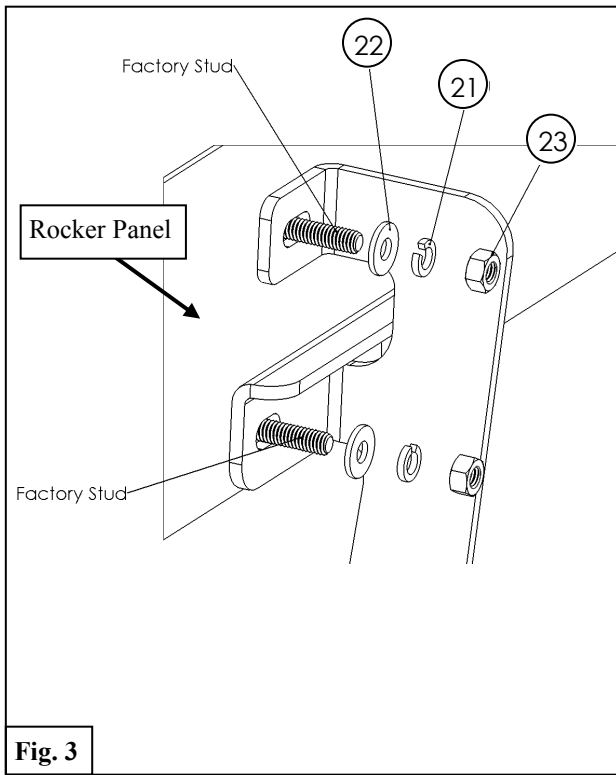

5. At the center passenger mounting location, loosely install Link Bracket (4) with preassembled Mounting Bracket Base (13) using the supplied M8 hardware. See **Figures 5 & 6**.

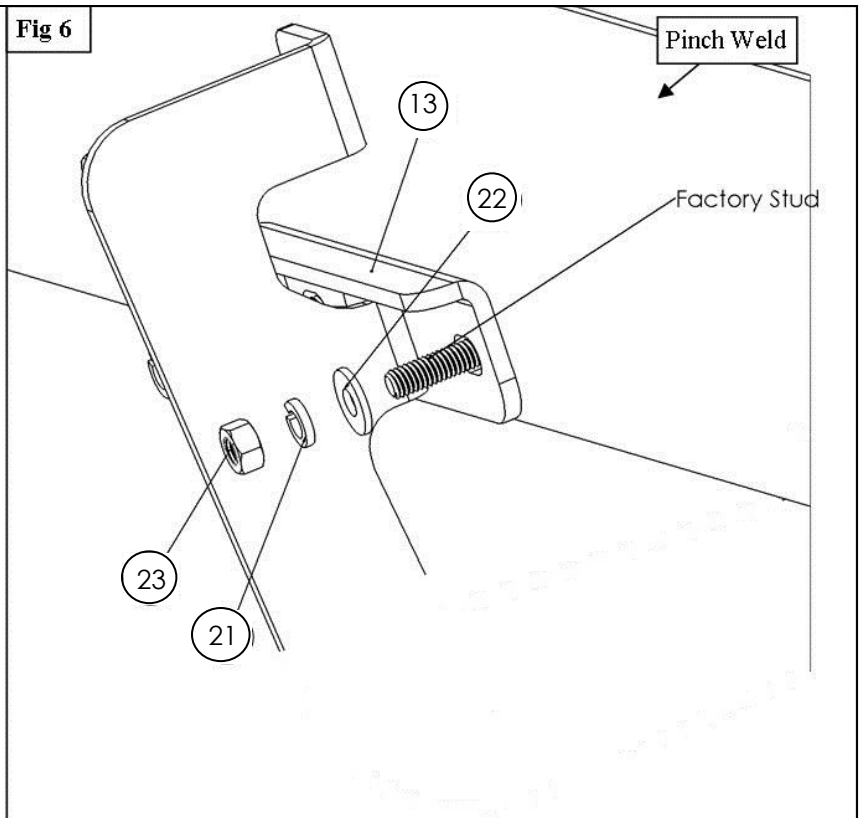
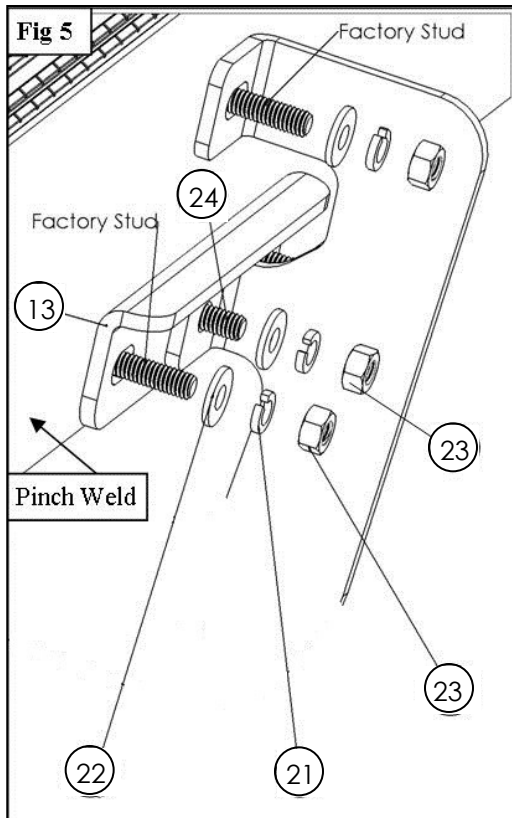

6. At the front passenger mounting location, loosely install Mounting Bracket B (9) with preassembled Mounting Bracket Base (13). **Note:** Installation is similar to Mounting Bracket A.
7. Repeat **Steps 4-7** on the driver side of the vehicle. **Note:** Driver Front will receive Mounting Bracket A (8) rather than B.
8. Moving to the rear-most location, install the Top Isolator Bracket (10), Top Isolator Brace (11), and Bottom Isolator Bracket along with the Isolator Kit (14). See **Figures 8 & 9**. You will need to first remove the bolt in the bed as shown in **Figure 7**. **Note:** A breaker-bar or impact gun will help in removal. The bolt is very tight.

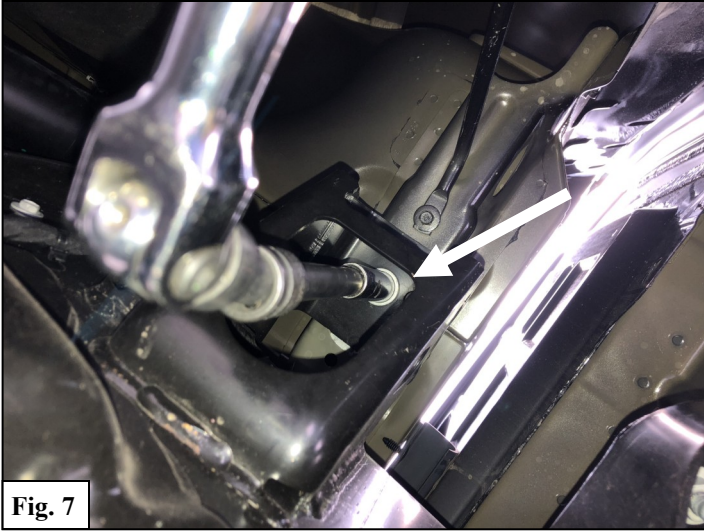

Fig. 7

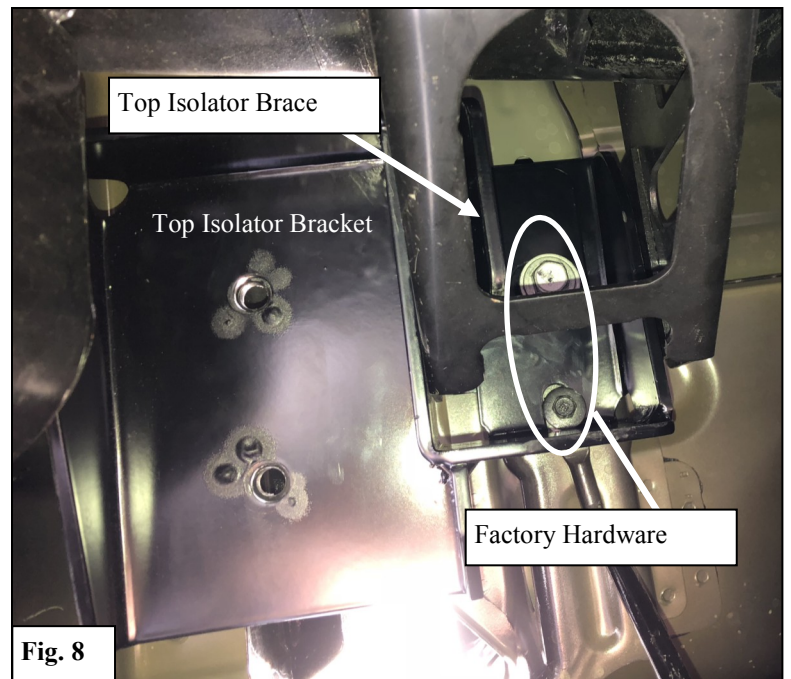

Fig. 8

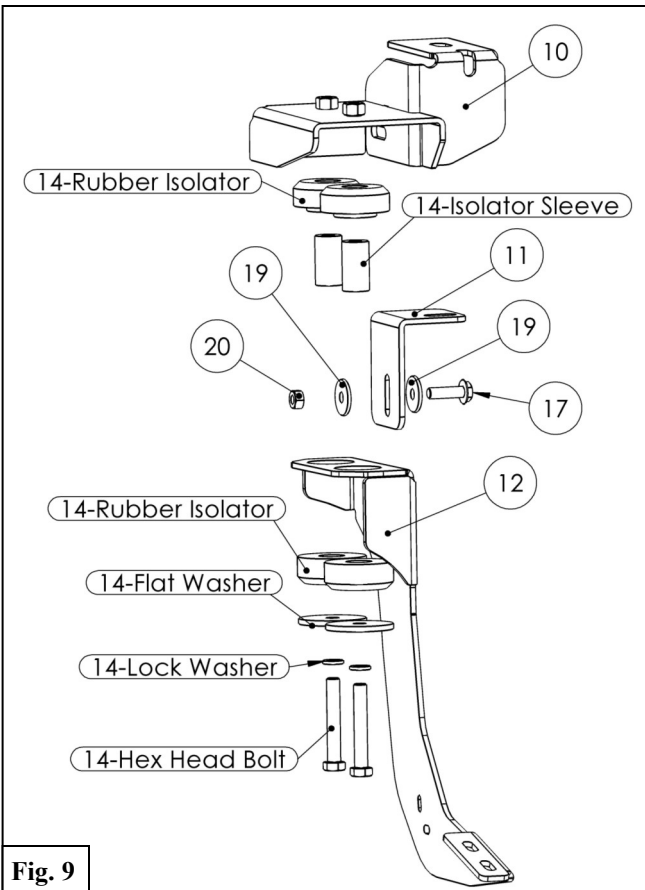

Fig. 9

9. Place the supplied step pad (3) into the holes to connect the two Step Bar sections (1 & 2). Place the supplied thread cutting nut on each of the plastic stems. Tighten until nut reaches metal and feels firm in place. See Figures 10 & 11.

Fig 10



Fig 11



10. Obtain both sections of the Step Bar Assembly (1 & 2). Slide the Reinforcement Links (6 & 7) into both sides of the step bar sections. See Figure 12.

11. Line up the holes on the Step Bar sections with the holes on the Reinforcement Links (6 & 7). See Figure 13.

Fig 12



Fig 13

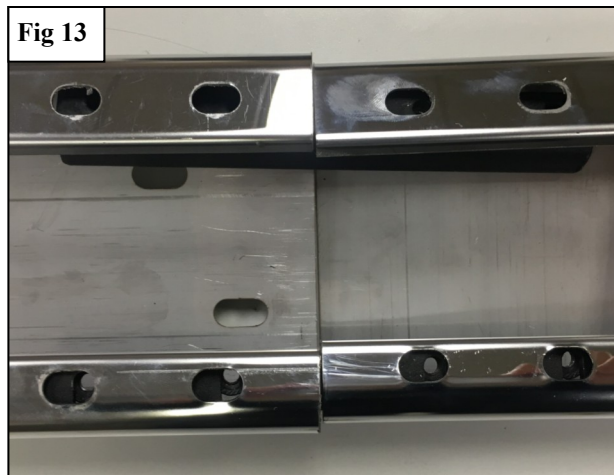

12. Obtain the Link Plate (5) and secure it to the Step Bar Assembly (1 & 2) using the supplied black M6 Hardware. See **Figure 14**. *Note:* Driver side shown.

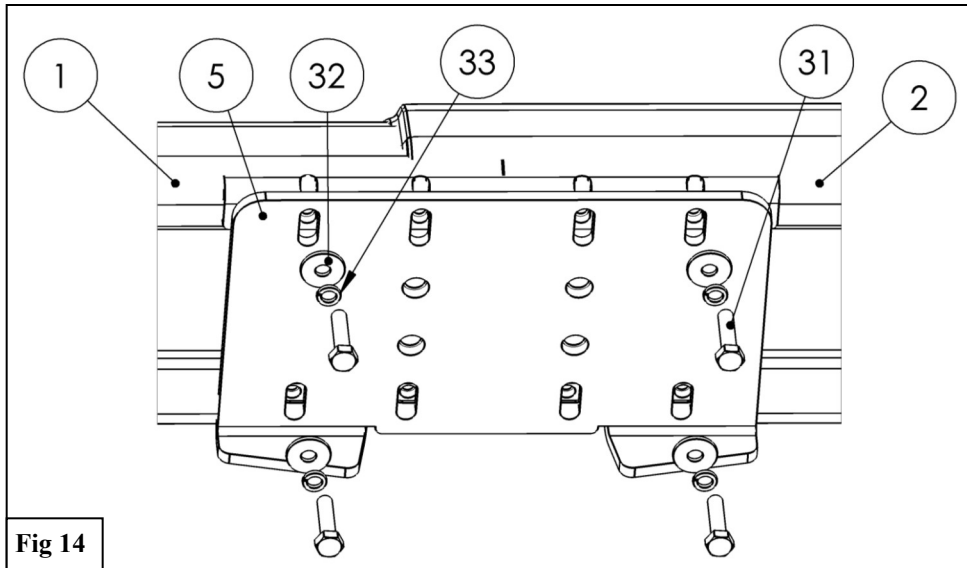

13. Installation of the step boards will utilize the supplied black M8 hardware with Plate Adapters (16) for all brackets excluding the Link Brackets (4). The Link Brackets (4) will use the supplied black M10 hardware. See **Figures 15 & 16**.
14. Align and adjust the step bars and brackets as needed, then fully tighten all hardware: M6 to 7 ft-lbs, M8 to 15-18 ft-lbs, M10 to 32-38 ft-lbs.

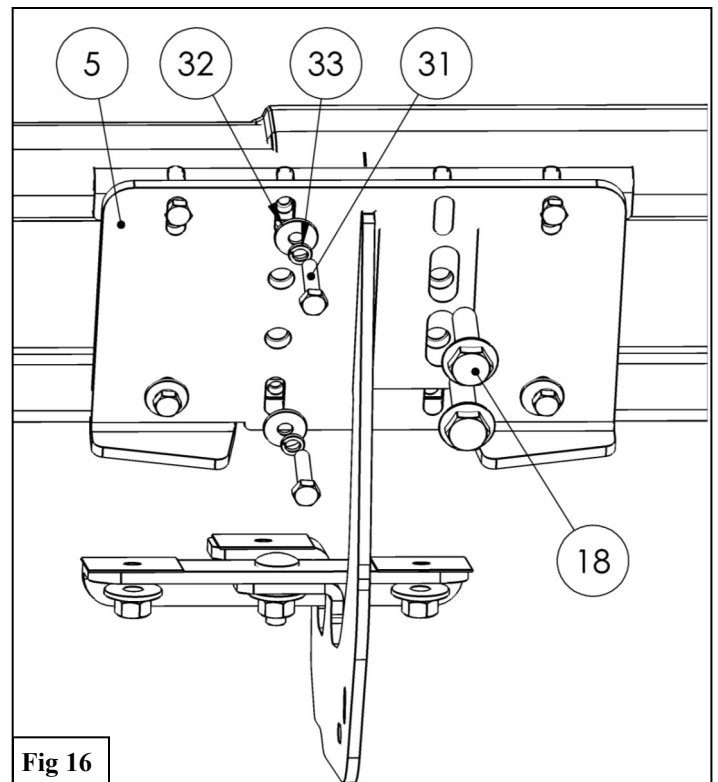
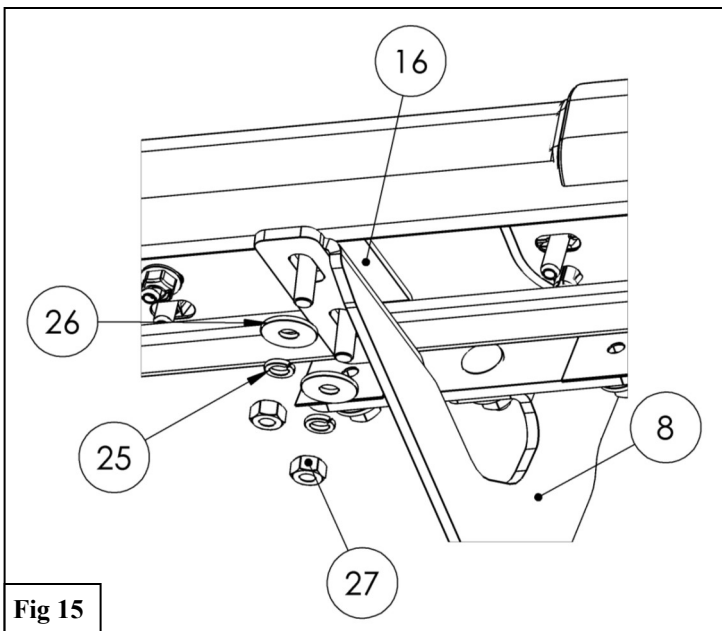

Plastic Cover Installation:

1. Locate (1) plastic bracket cover (Item 15) and loosely secure it to the brackets using the provided hardware: (2) M6 hex head cap screws, (4) M6 flat washers, and (2) M6 nylock nuts. Repeat for every bracket. See **Figure 17**.

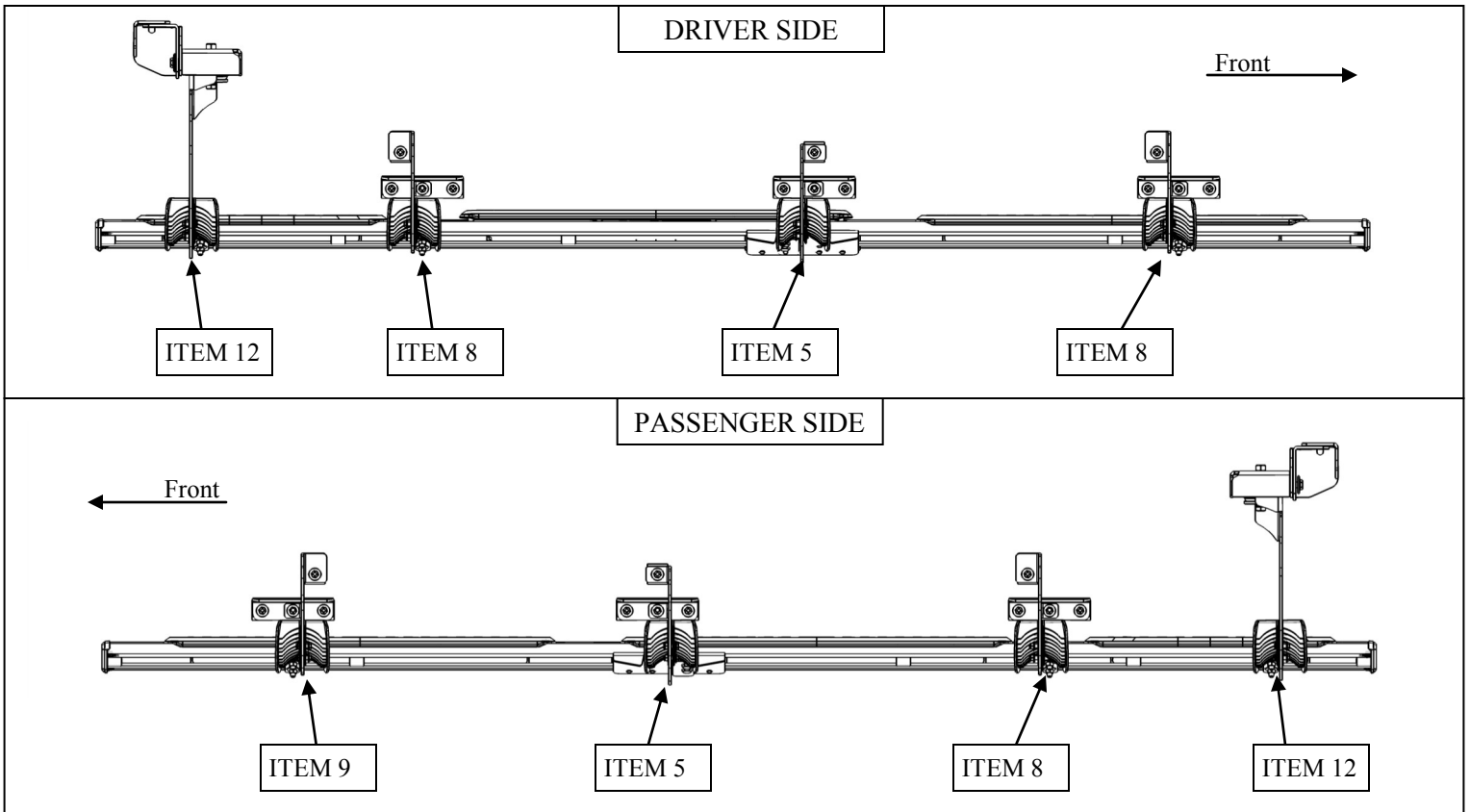
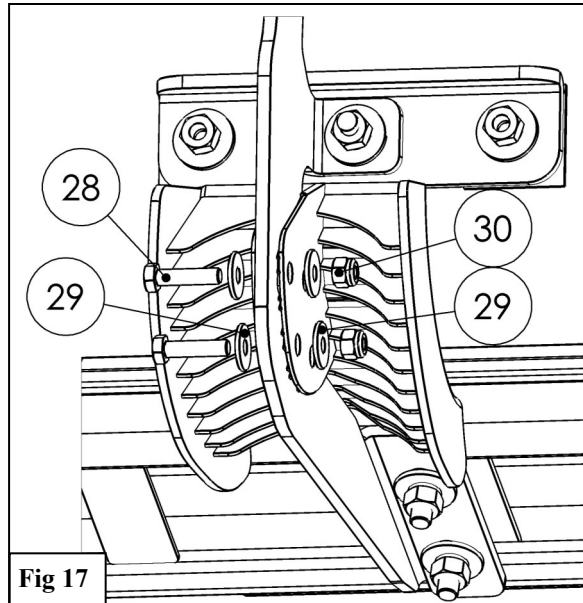

INSTALLATION COMPLETE



CARE INSTRUCTIONS

- REGULAR WAXING IS RECOMMENDED. DO NOT USE ANY TYPE OF POLISH OR WAX THAT MAY CONTAIN ABRASIVES
- STAINLESS STEEL PRODUCTS CAN BE CLEANED WITH MILD SOAP AND WATER. STAINLESS STEEL POLISH SHOULD BE USED TO POLISH SMALL SCRATCHES.
- GLOSS BLACK FINISHES SHOULD BE CLEANED WITH MILD SOAP AND WATER

WESTIN



WARNING



Failure to follow these instructions could lead to death, personal injury, and / or property damage.

Failure to follow these instructions could lead to death, personal injury, and / or property damage.

FASTENERS:

All Westin supplied fasteners must be utilized and installed in accordance with the installation instructions and apply torque to the specifications as defined. **DOUBLE CHECK ALL FASTENERS BEFORE INITIAL USE, AND PERIODICALLY IN THE FUTURE TO ENSURE PROPER FUNCTION AND SAFETY.**

DRILLING:

Most Westin products do not require drilling for installation. If drilling is defined as required, use caution when drilling a vehicle. **FAILURE TO REVIEW AN AREA TO BE DRILLED MAY RESULT IN PERSONAL INJURY AND/OR INJURY TO OTHERS AS WELL AS VEHICLE DAMAGE.**

EYE PROTECTION:

ALWAYS WEAR SAFETY GLASSES OR GOGGLES DURING THE INSTALLATION PROCESS TO AVOID PERSONAL INJURY.

MAXIMUM TOWING/CARRYING CAPACITY: (if applicable)

The Westin Receiver Hitches will have a visible tow rating label affixed directly on the product. User should never exceed the vehicle manufacturers maximum tow and weight rating regardless of the capacity of the hitch. **FAILURE TO FOLLOW THESE GUIDELINES WILL VOID THE WESTIN WARRANTY AND MAY RESULT IN PERSONAL INJURY AND/OR INJURY TO OTHERS AS WELL AS VEHICLE DAMAGE.**



Learn more about running boards and step bars we have.