

INSTALLATION INSTRUCTIONS

R5 WHEEL TO WHEEL NERF STEP BAR



APPLICATION:

2019 Chevy Silverado/GMC Sierra 1500 Crew Cab (5.5 ft. Bed);
 2019 Chevy Silverado/GMC Sierra 1500 Crew Cab (6.5 ft. Bed);
 2019 Chevy Silverado/GMC Sierra 1500 Double Cab (6.5 ft. Bed)
 (Excl. 2019 Silverado LD/sierra 1500 Limited)

PART NUMBER:

28-534680, 28-534685 , 28-534690 , 28-534695 .

CONTENT			
ITEM	QUANTITY	DESCRIPTION	TOOLS NEEDED
1	2	STEP BAR ASSEMBLY FRONT SECTION (1 DRIVER, 1 PASSENGER)	16MM SOCKET
2	2	STEP BAR ASSEMBLY REAR SECTION (1 DRIVER, 1 PASSENGER)	16MM WRENCH
3	2	STEP PAD	13MM SOCKET
4	2	LINK BRACKET (1 DRIVER, 1 PASSENGER)	13MM WRENCH
5	2	LINK PLATE	10MM SOCKET
6	2	TALL REINFORCEMENT LINK	10MM WRENCH
7	2	SHORT REINFORCEMENT LINK	15MM SOCKET
8	6	MOUNTING BRACKET (3 DRIVER, 3 PASSENGER)	1/2" EXTENSION
9	8	PLATE ADAPTER	RATCHET
10	1	TOP ISOLATOR BRACKET AND STRAP DRIVER	TORQUE WRENCH
11	1	TOP ISOLATOR BRACKET AND STRAP PASSENGER	IMPACT GUN
12	4	ISOLATOR KIT (RUBBER PUCKS, LARGE WASHER, M12 BOLT, M12 NUT, M12 SPLIT LOCK WASHER)	BREAKER BAR
13	2	BOTTOM ISOLATOR BRACKET (1 DRIVER, 1 PASSENGER)	
14	10	PLASTIC BRACKET COVER	
15	3	M12 HEX HEAD BOLT	
16	3	M12 SPLIT LOCK WASHER	
17	7	M12 FLAT WASHER	
18	4	M10 FLANGED HEX HEAD BOLT	
19	16	M8 HEX NUT	
20	32	M8 SPLIT LOCK WASHER (16 SEMS HARDWARE)	
21	32	M8 FLAT WASHER (16 SEMS HARDWARE)	
22	16	M8 HEX HEAD CAP SCREW (16 SEMS HARDWARE)	
23	20	M6 HEX HEAD CAP SCREW (YELLOW ZINC)	
24	40	M6 FLAT WASHER (YELLOW ZINC)	
25	20	M6 NYLOCK NUT (YELLOW ZINC)	
26	12	M6 HEX HEAD CAP SCREW (BLACK ZINC)	
27	12	M6 SPLIT LOCK WASHER (BLACK ZINC)	
28	12	M6 FLAT WASHER (BLACK ZINC)	
29	3	NUT PLATE	



ITEM 1			ITEM 2		
	Driver Side Front Marking	Passenger Side Front Marking		Driver Side Rear Marking	Passenger Side Rear Marking
				28-534690 & 28-534695	

ITEM 3	ITEM 4	ITEM 5

ITEM 6	ITEM 7	ITEM 8	ITEM 9

ITEM 10	ITEM 11	ITEM 12	ITEM 13

ITEM 14

**DRIVER SIDE ITEMS SHOWN
PASSENGER SIDE OPPOSITE
WHEN APPLICABLE**

PROCEDURE

1. Remove contents from box, verify if all parts listed are present and free from damage.

Carefully read and understand all instructions before attempting installation.

Failure to identify damage before installation could lead to a rejection of any claim.

2. Starting on the driver side, remove the rubber plugs located on the rocker panel at each mounting location. See **Figure 1**.

3. **For models with threaded holes:** At each bracket mounting location on the rocker panel there should be a welded factory nut.



Figure 1

4. Locate (1) Mounting Bracket (Item 3) and loosely secure it to the rocker panel using the provided hardware: (2) M8 hex head bolt, (2) M8 flat washer, and (2) M8 lock washer. See **Figure 3**. (Use SEMS hardware)

5. Repeat **Step 4** for all remaining bracket mounting locations. See **Figure 16**.

6. Install link brackets **Item 4** on third mounting location. See **Figure 2**. (Passenger side is mirror opposite of image shown on Page 2)

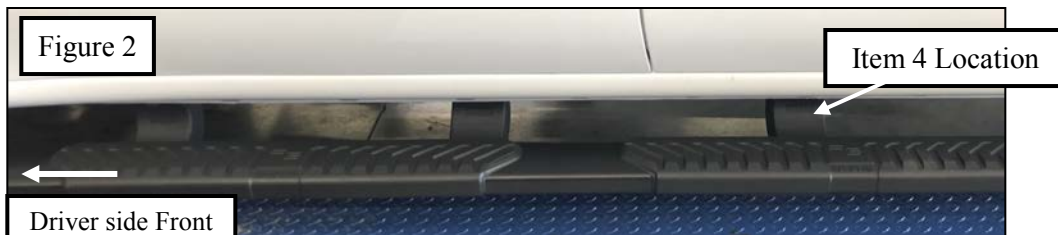
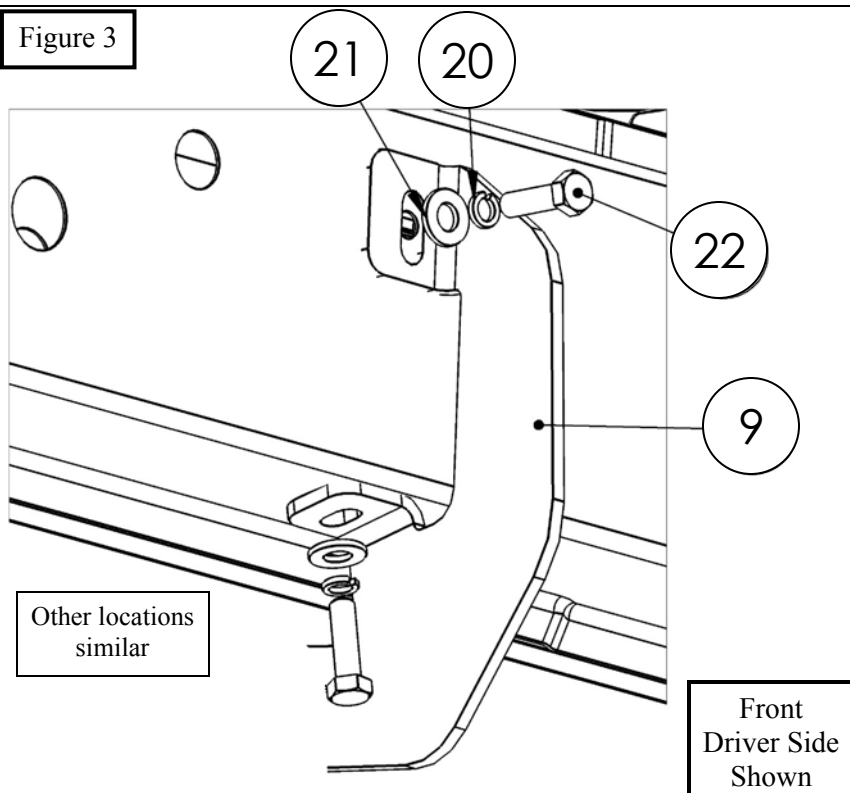

Figure 2

Item 4 Location

Driver side Front

Figure 3



6. Remove the OEM Bed bolts to be used on the top Isolator Bracket (10). Then install the Top Isolator Bracket (10) using the OEM bolts, supplied Nut Plate (29), and supplied M12 Bolt, M12 Lock Washer, and M12 Flat Washer. See **Figures 4 & 5**. Use **Item 11** for passenger side. See **Figure 7**

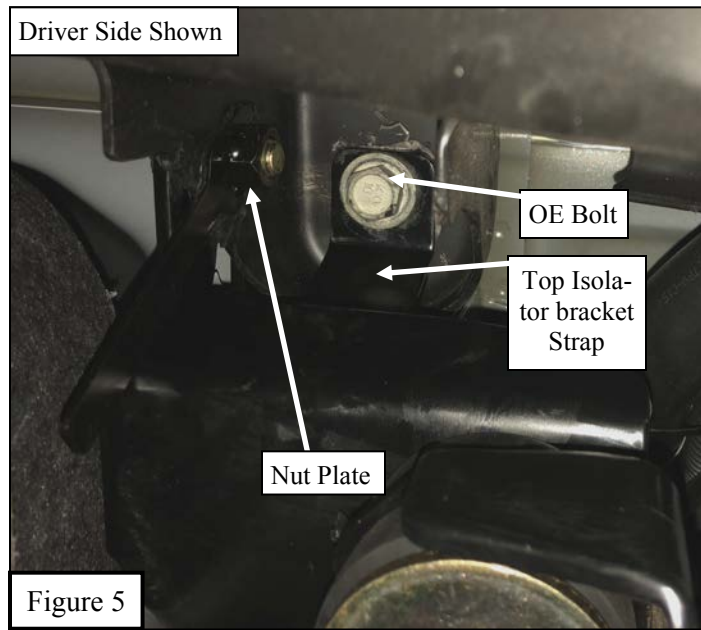
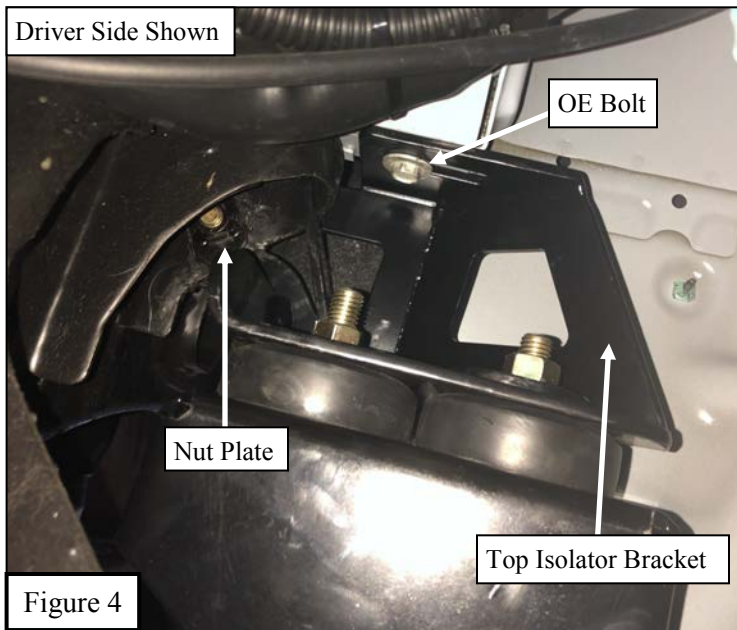

7. For Double Cab and Crew Cab models with a 6.5' Bed, on passenger side: Remove the rear wheel well liner and then drill a 1/2" hole for the Top Isolator Bracket. See **Figures 6 & 7**.

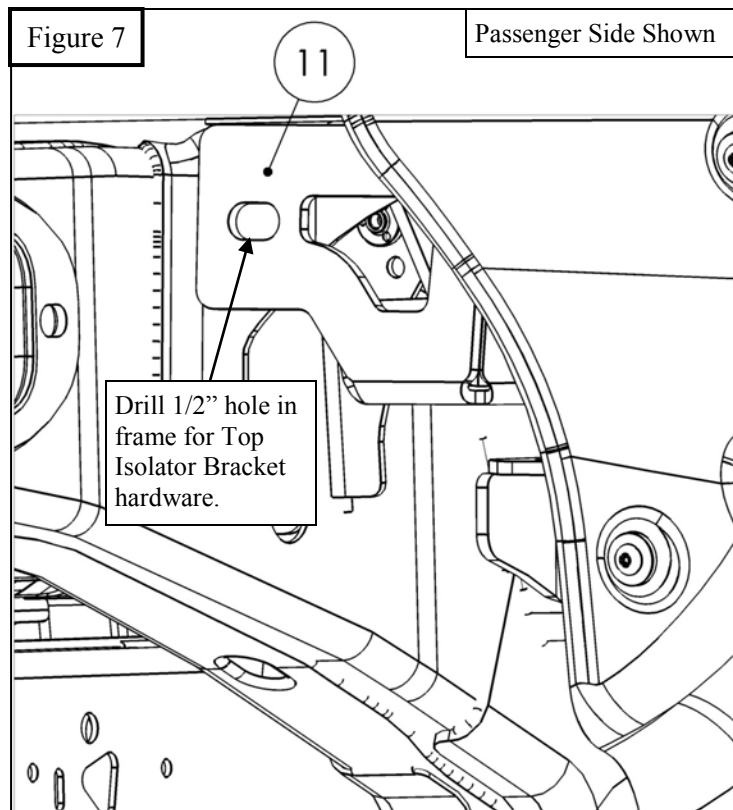
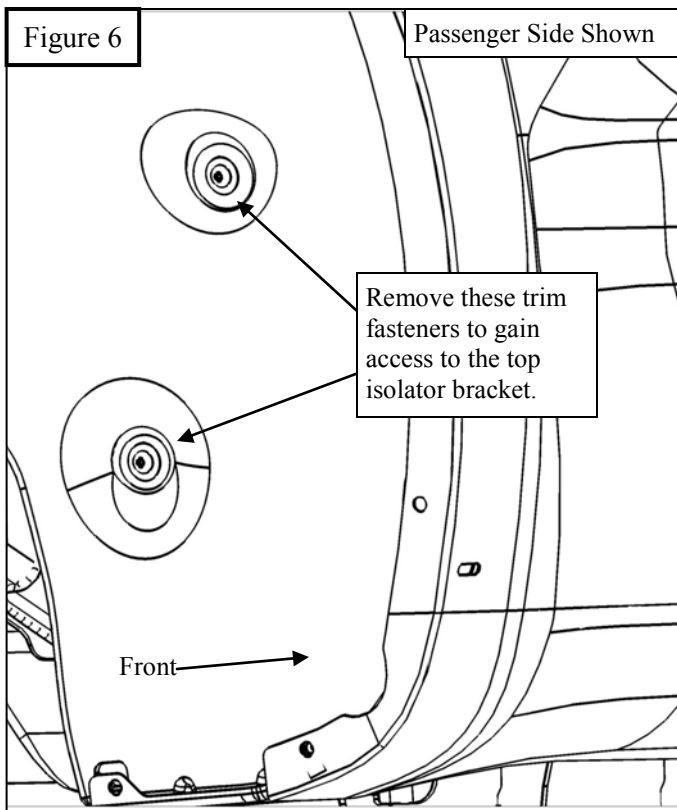



8. Attach the Bottom Isolator Bracket (13) to the Top Isolator Bracket (10,11) using the Isolator Kit (12) and hardware. See **Figure 8, 9.**

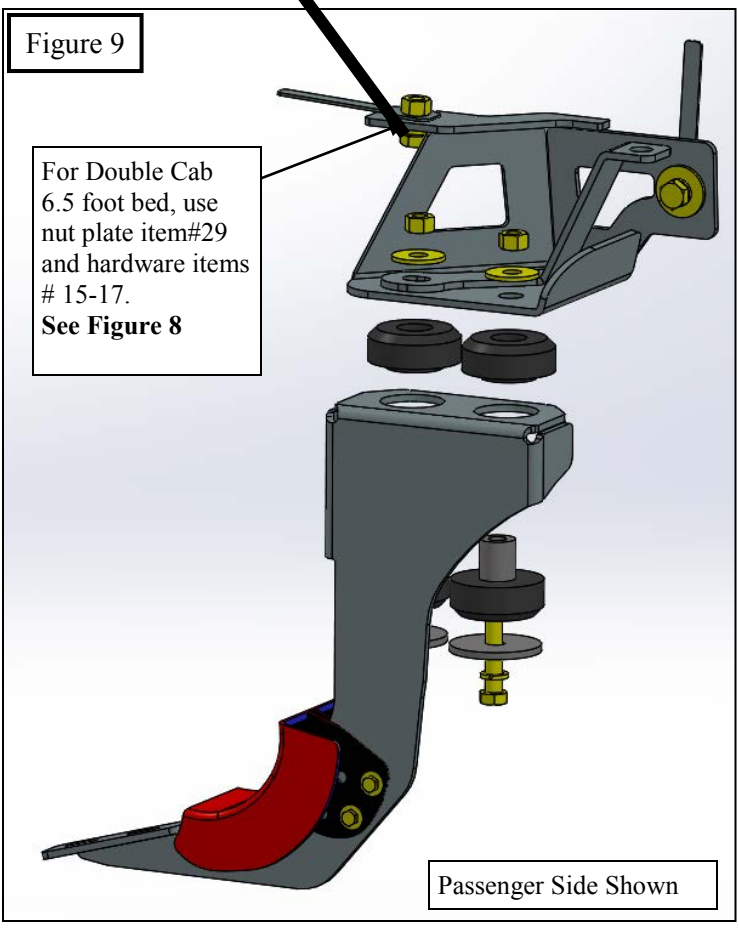
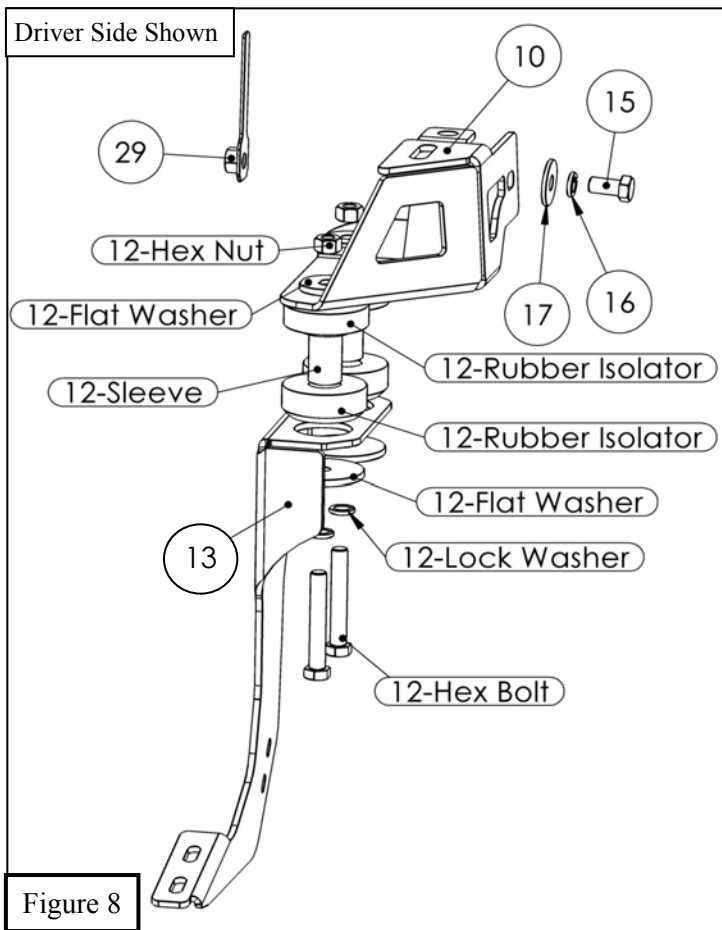

9. Place the supplied step pad (3) into the holes to connect the two Step Bar sections (1 & 2). Place the supplied thread cutting nut on each of the plastic stems. Tighten until nut reaches metal and feels firm in place. See Figures 10 & 11.

Fig 10



Fig 11



10. Obtain both sections of the Step Bar Assembly (1 & 2). Slide the Reinforcement Links (6 & 7) into both sides of the step bar sections. See Figure 12.

11. Line up the holes on the Step Bar sections with the holes on the Reinforcement Links (6 & 7). See Figure 13.

Fig 12



Fig 13



15. Secure the Plastic Bracket Covers (4) to the Mounting Brackets using the supplied M6 Hardware. See **Figure 17**.
16. Align and adjust the step bars as needed and fully tighten all hardware. Torque all M6 fasteners to 5-7 ft-lbs and all M8 fasteners to 15-18 ft-lbs.

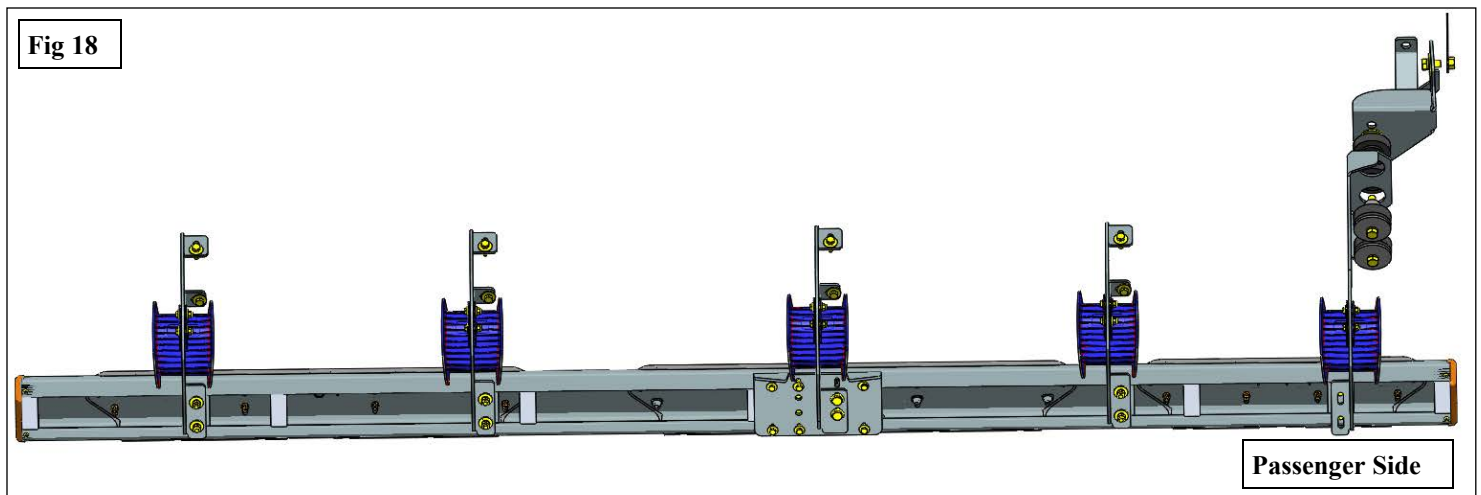
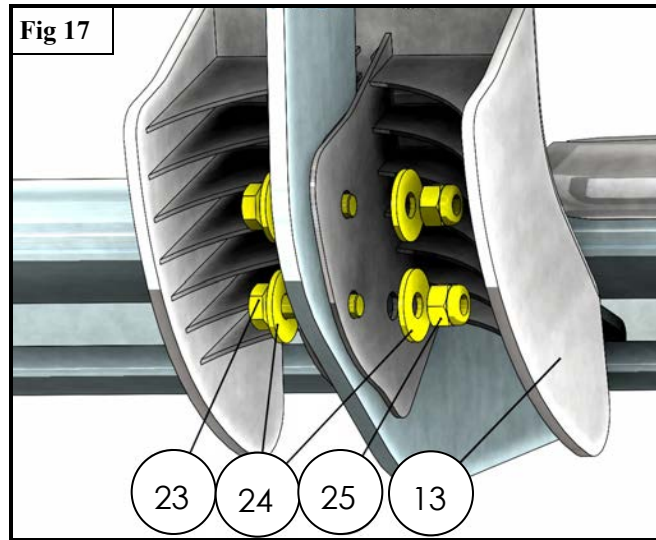

INSTALLATION COMPLETE



WESTIN

INSTALLATION COMPLETE





WARNING



Failure to follow these instructions could lead to death, personal injury, and / or property damage.

Failure to follow these instructions could lead to death, personal injury, and / or property damage.

FASTENERS:

All Westin supplied fasteners must be utilized and installed in accordance with the installation instructions and apply torque to the specifications as defined. **DOUBLE CHECK ALL FASTENERS BEFORE INITIAL USE, AND PERIODICALLY IN THE FUTURE TO ENSURE PROPER FUNCTION AND SAFETY.**

DRILLING:

Most Westin products do not require drilling for installation. If drilling is defined as required, use caution when drilling a vehicle. **FAILURE TO REVIEW AN AREA TO BE DRILLED MAY RESULT IN PERSONAL INJURY AND/OR INJURY TO OTHERS AS WELL AS VEHICLE DAMAGE.**

EYE PROTECTION:

ALWAYS WEAR SAFETY GLASSES OR GOGGLES DURING THE INSTALLATION PROCESS TO AVOID PERSONAL INJURY.

MAXIMUM TOWING/CARRYING CAPACITY: (if applicable)

The Westin Receiver Hitches will have a visible tow rating label affixed directly on the product. User should never exceed the vehicle manufacturers maximum tow and weight rating regardless of the capacity of the hitch. **FAILURE TO FOLLOW THESE GUIDELINES WILL VOID THE WESTIN WARRANTY AND MAY RESULT IN PERSONAL INJURY AND/OR INJURY TO OTHERS AS WELL AS VEHICLE DAMAGE.**



Learn more about running boards and step bars we have.