



INSTALLATION INSTRUCTIONS

R5 MODULAR WHEEL TO WHEEL NERF STEP BARS

APPLICATION:

2007-2019 Chevy Silverado / GMC Sierra 2500-3500 Crew Cab
(8ft. Bed) Excl. Dually

PART NUMBER:

28-534580, 28-534585

ITEM	QUANTITY	DESCRIPTION	TOOLS NEEDED
1	2	STEP BAR FRONT SECTION (1 DRIVER, 1 PASSENGER)	18MM SOCKET
2	2	STEP BAR REAR SECTION (1 DRIVER, 1 PASSENGER)	18MM WRENCH
3	2	STEP PAD	16MM WRENCH
4	2	REINFORCEMENT LINK TALL	16MM SOCKET
5	2	REINFORCEMENT LINK SHORT	13MM WRENCH
6	2	LINK PLATE	10MM SOCKET
7	2	LINK BRACKET (1 DRIVER, 1 PASSENGER)	10MM WRENCH
8	16	SELF THREADING NUTS	RATCHET
9	6	MOUNTING BRACKET (A-4x, B-1x, C-1x)	TORQUE WRENCH
10	2	TOP ISOLATOR BRACKET (1 DRIVER, 1 PASSENGER)	
11	2	BOTTOM ISOLATOR BRACKET (1 DRIVER, 1 PASSENGER)	
12	4	ISOLATOR KIT	
13	10	PLASTIC BRACKET COVER	
14	8	PLATE ADAPTER	
15	2	M10 BOLT PLATE	
16	4	M10 HEX NUT	
17	4	M10 SPLIT LOCK WASHER	
18	4	M10 FLAT WASHER	
19	4	M10 HEX HEAD FLANGE BOLT (Black Zinc)	
20	2	M10 FISH WIRE	
21	16	M8 U-NUT	
22	4	M8 RIV-NUT	
23	18	M8 HEX HEAD CAP SCREW	
24	34	M8 SPLIT LOCK WASHER (16 Black Zinc)	
25	34	M8 FLAT WASHER (16 Black Zinc)	
26	16	M8 HEX NUT (Black Zinc)	
27	32	M6 HEX HEAD CAP SCREW (12 Black Zinc)	
28	52	M6 FLAT WASHER (12 Black Zinc)	
29	12	M6 SPLIT LOCK WASHER (Black Zinc)	
30	20	M6 NYLOCK NUT	
31	1	UNIVERSAL RIV-CERT TOOL	
32	4	M12 BOLT LONG	
33	4	M12 SPLIT LOCK WASHER	

ANTI-SEIZE LUBRICANT MUST BE USED ON ALL STAINLESS STEEL FASTENERS TO PREVENT THREAD DAMAGE AND GALLING



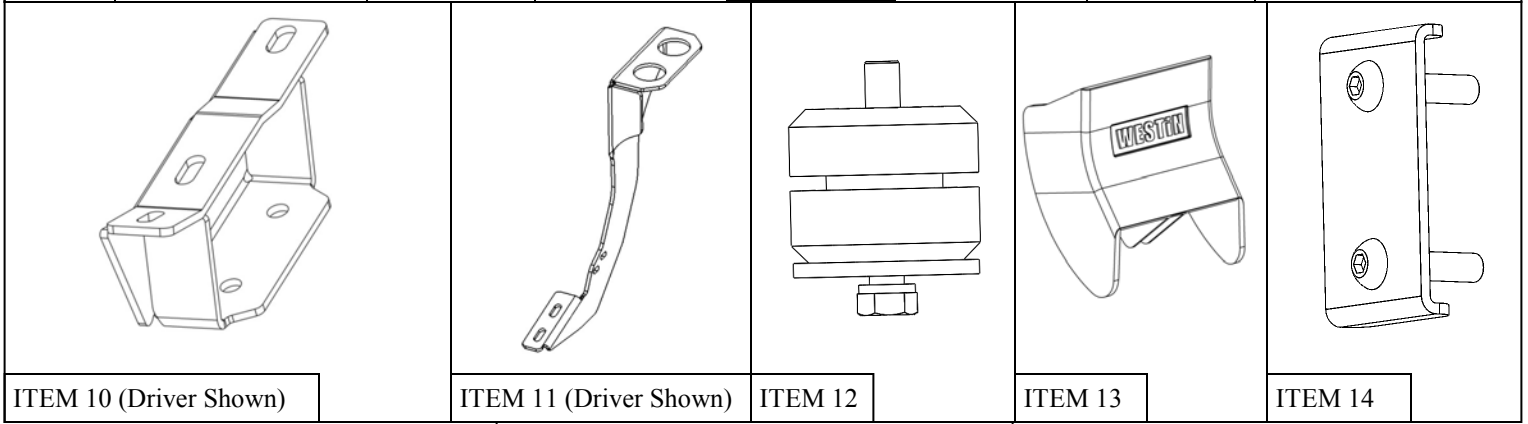
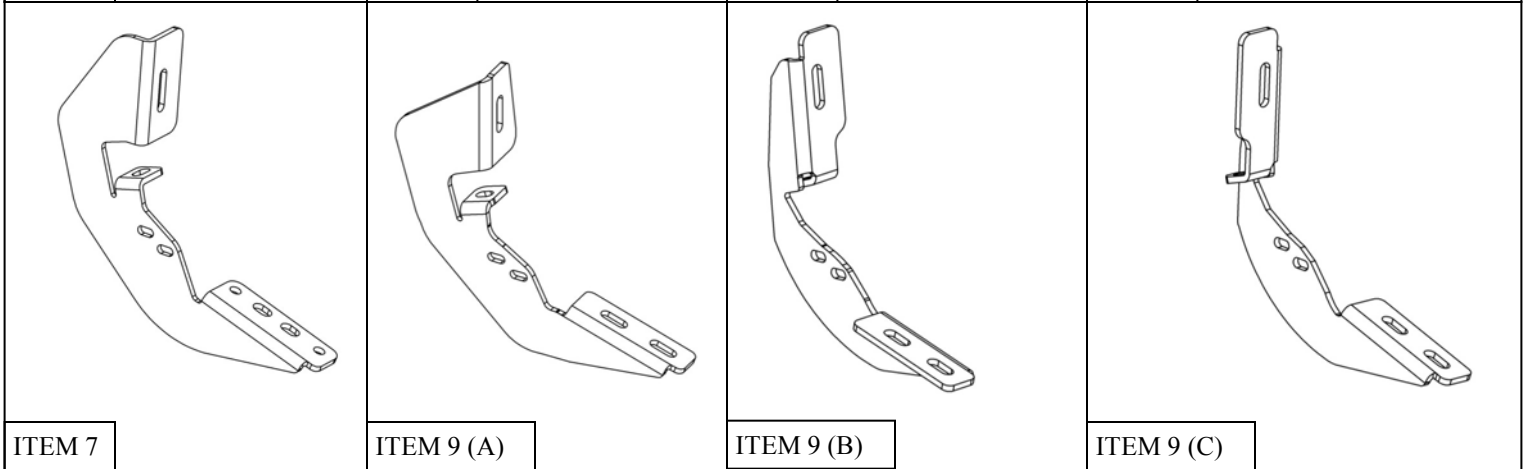
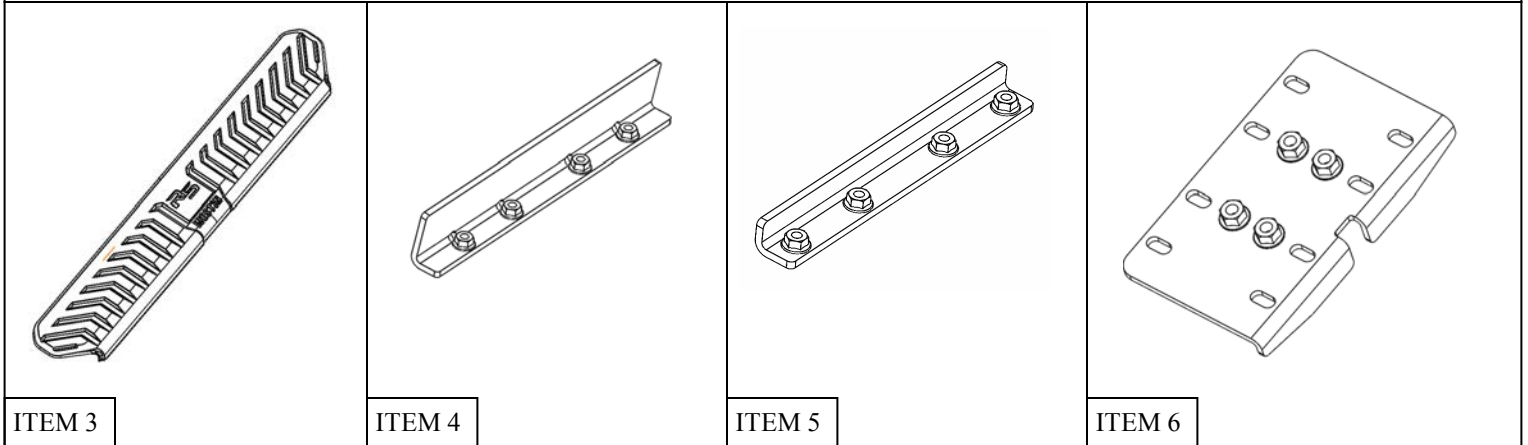
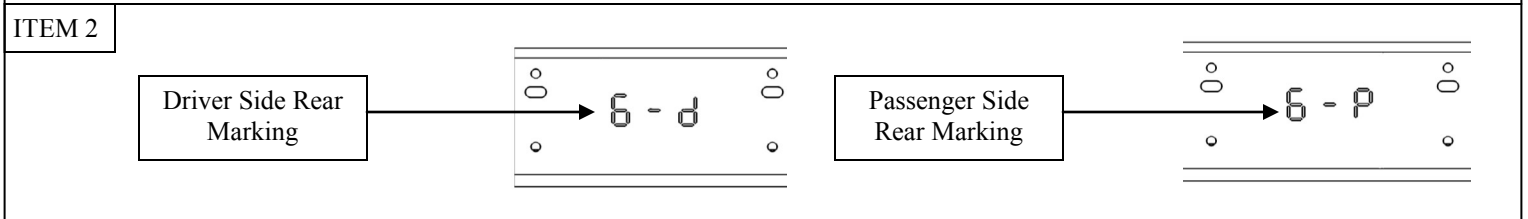
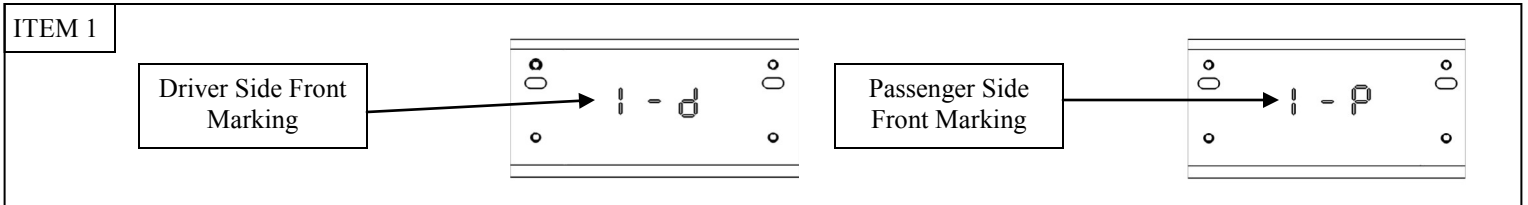

PASSENGER SIDE ITEMS SHOWN

PROCEDURE

1. Remove contents from box, verify if all parts listed are present and free from damage.

Carefully read and understand all instructions before attempting installation.

Failure to identify damage before installation could lead to a rejection of any claim.

2. Starting on the driver side, remove the rubber plugs located on the rocker panel at each mounting location. See **Figure 1**.
3. **For models with welded nuts:** At each bracket mounting location on the pinch weld there should either be a welded factory nut or a hole. If there is a factory welded nut present, then the M8 U-Nut Clip (Item 21) will not be used at that location. See **Figure 2** for the factory welded nut.

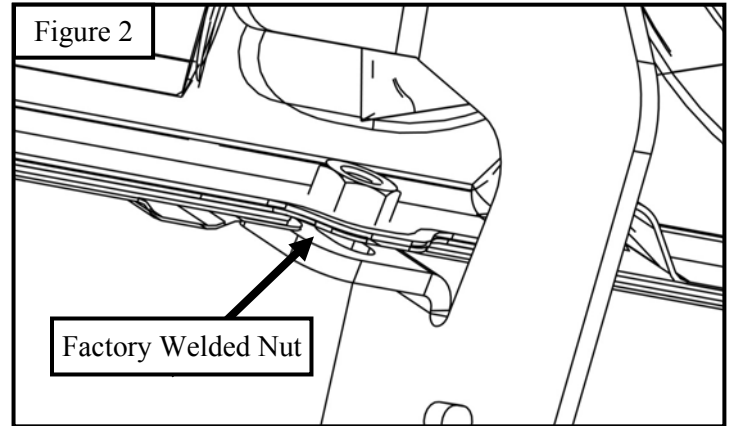
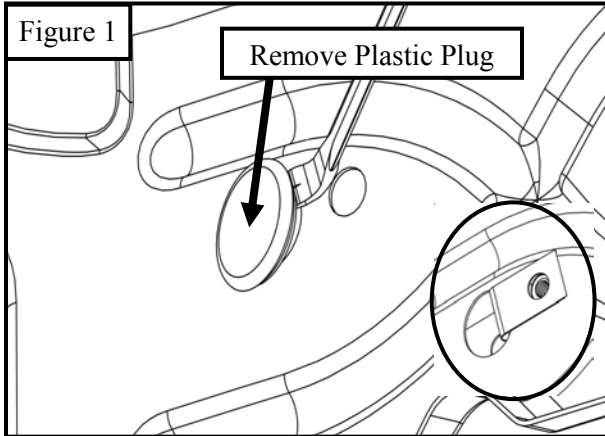

4. Insert (1) M8 u-nut clip (Item 21) into the hole where the rubber plug was removed. Clip (1) M8 u-nut clip onto pinch weld if no factory welded nut is present. Locate (1) Mounting Bracket A (Item 9) and loosely secure it to the rocker panel using the provided hardware: (2) M8 hex head bolt long, (2) M8 flat washer, and (2) M8 lock washer. See **Figure 3**.
5. Repeat **Step 4**, moving one location back on the vehicle. *Go to page 9 for supplementary bracket orientation diagram.*



6. Install the Link Bracket (Item 7) using the supplied hardware: (2) M8 hex head bolt long, (2) M8 flat washer, and (2) M8 lock washer. See **Figure 4**.

Fig 4

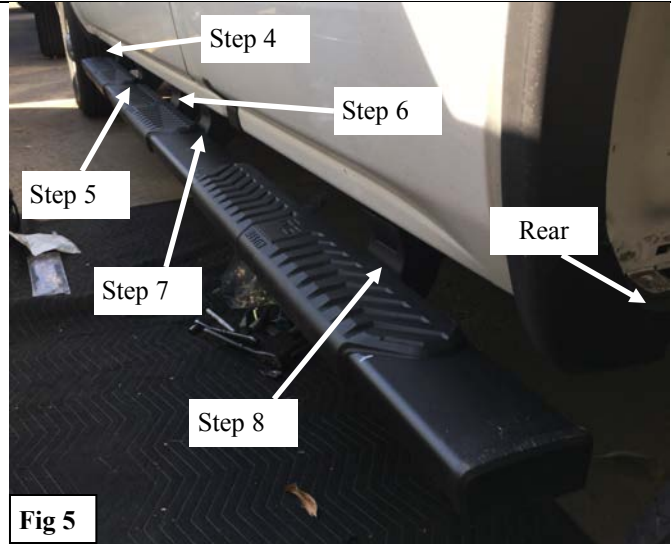

7. Repeat **Step 4** using Mounting Bracket B (Driver) or C (Passenger), moving one location back on the vehicle.

FOR DIESEL TRUCKS

For 2007-2016 Diesel equipped models: The DEF tank must be removed prior to installing the brackets on the passenger side. For DEF tank removal instructions please refer to **page 9**.

For 2017-18 Diesel equipped models: *DEF tank removal is not necessary for 2017-18 diesel equipped models.* Only need to remove DEF tank plastic cover in order to install mount brackets. Refer to **Step 8**.

8. Using a 10MM wrench, remove the four bolts that hold the DEF tank plastic cover to the vehicle. See **Figure 6**.
9. Locate (1) mount bracket A (Item 9) and loosely secure onto vehicle using the provided M8 hardware. See **Figure 7**. **Note:** Passenger side front/center mount location will install the same but will use mount bracket B/C (Item 9) for diesel applications. (**Figure 8**) **Note:** For installation on diesel equipped vehicles follow diesel exhaust fluid tank removal instructions on **page 10**.
10. Locate (1) plastic bracket cover (Item 13) and loosely secure onto mount bracket using the provided M6 hardware (Items 27-30). See **Figure 9**.

Figure 6

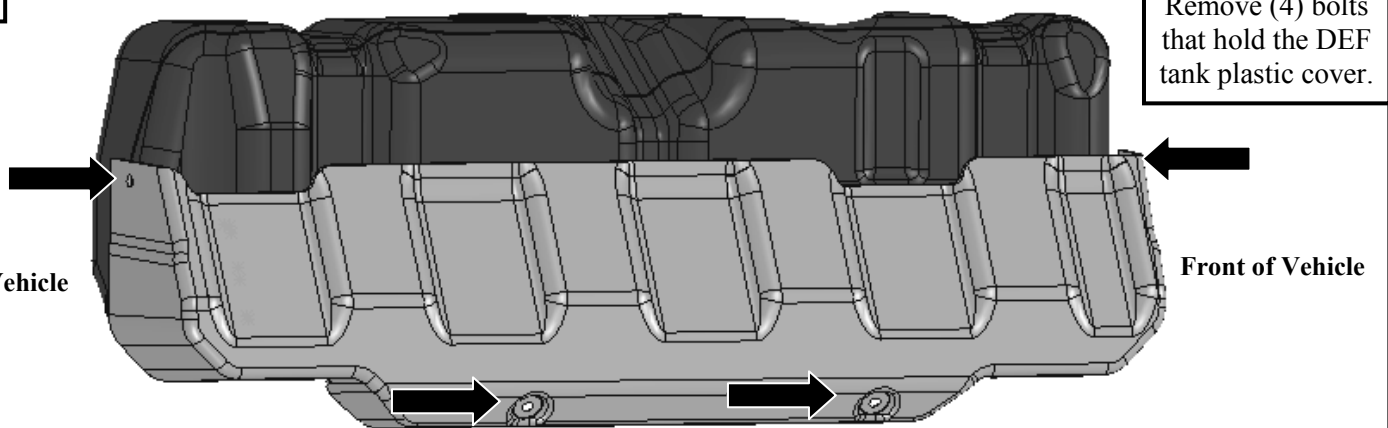

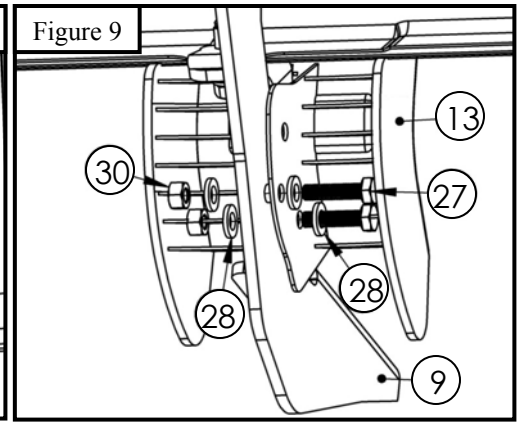
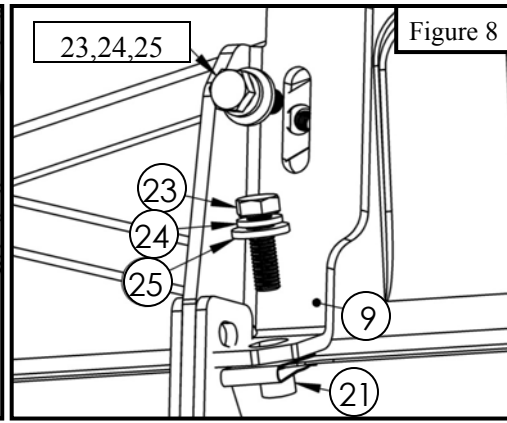
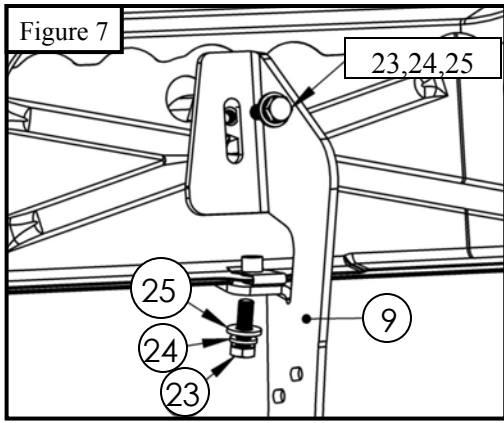

GAS AND DIESEL TRUCKS

11. Locate the Bed Rail immediately after the first, this will be the mount location for the Top Isolator Bracket (Item 10). Remove the Factory M12 Bolt from the Bed Mount. If the curved portion at the front of the rail has a threaded hole (Item 10) will be installed with the supplied M8 hardware and the previously removed Factory M12 Bolt. See **Figures 10 and 13**.
12. If the hole is not threaded in the curved portion of the bed rail, then a 27/64" hole must be drilled out. Once the hole is drilled out, insert the supplied M8 riv-nut (Item 22). (**Note:** Riv-nut should fit snug in the hole, should **not** spin easily. 2 extra riv-nuts are provided in case damage occurs to the riv-nut or failure to install). See **Figures 11 and 12**.

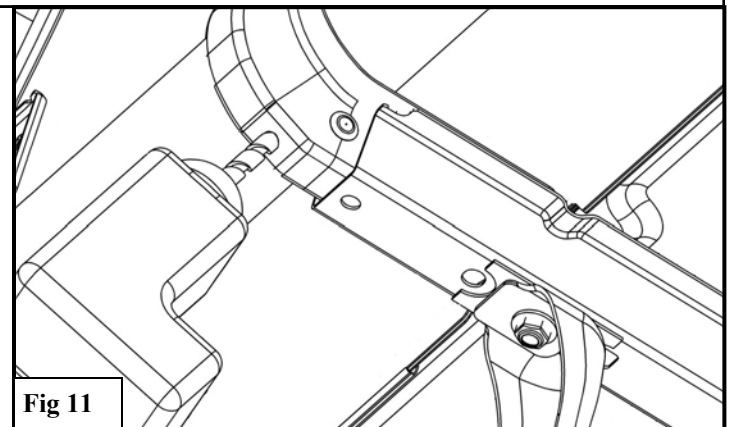
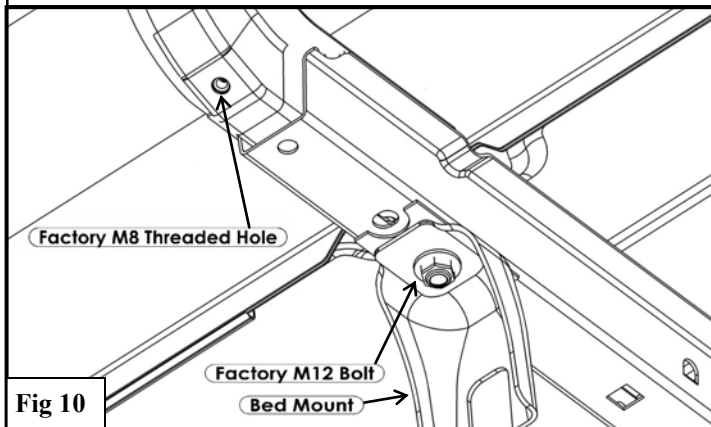

13. Once riv-nut is in place use the supplied Riv-Nut Hand Tool (Item 31) by applying pressure on the surface of the previously placed M8 riv-nut. Use the supplied black M8 bolt (Item 23) and begin to torque the bolt through the hand tool and into the riv-nut while constantly applying pressure to assure the M8 riv-nut does not spin. Once the riv-nut is fully installed, grab (Item 10) and install with supplied M8 hardware and Factory M12 Bolt. See **Figure 8 and 9**.
14. If the bed rail does not curve and instead has an open end with an existing hole, insert supplied M10 bolt plate (Item 15) through the existing hole. Then Install Top Isolator Bracket (Item 10) with supplied M10 hardware and previously removed Factory M12 Bolt. See **Figures 10 and 11**.

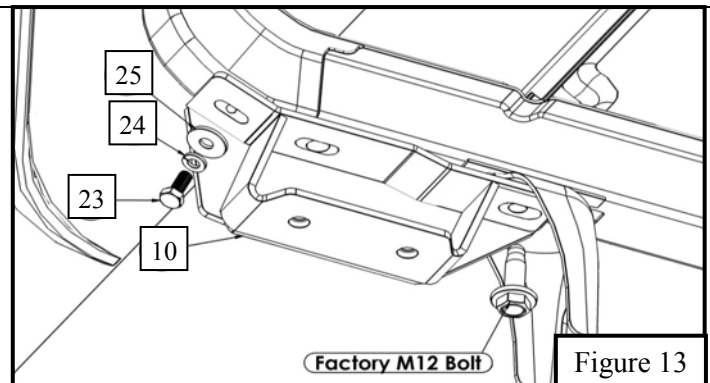
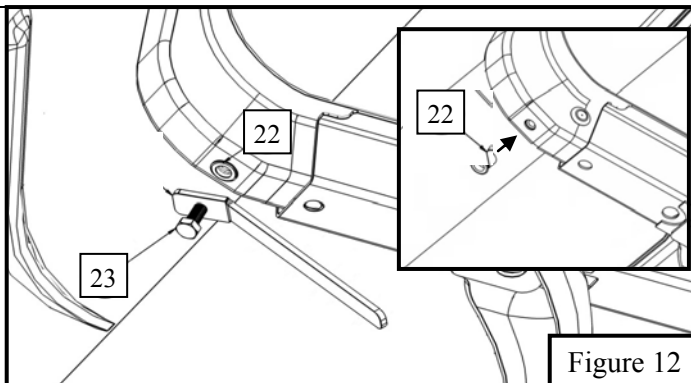

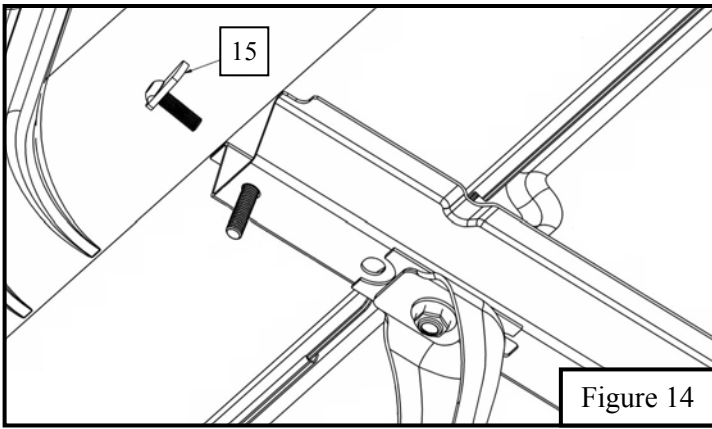

Figure 14

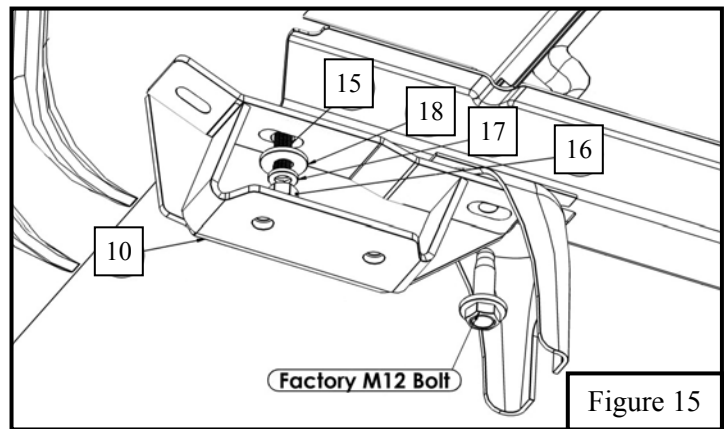

Figure 15

15. Install Bottom Isolator Bracket (Item 11) to previously mounted Top Isolator Bracket (Item 10) with supplied Isolator Kit (Item 12) and M12 Hardware. Assemble loosely. See **Figure 16**

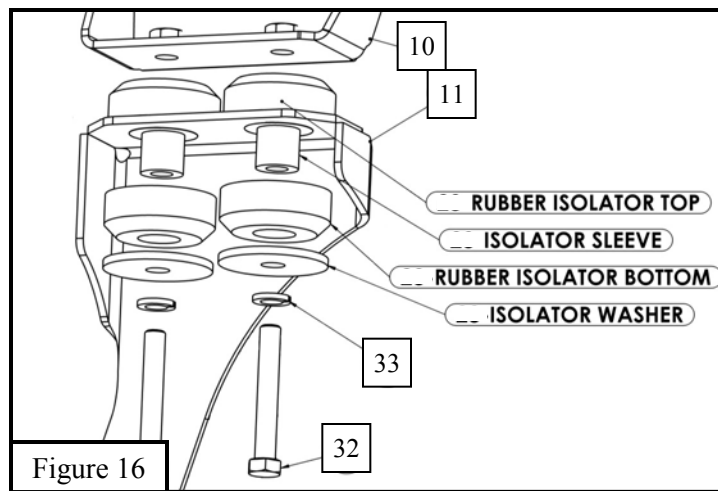
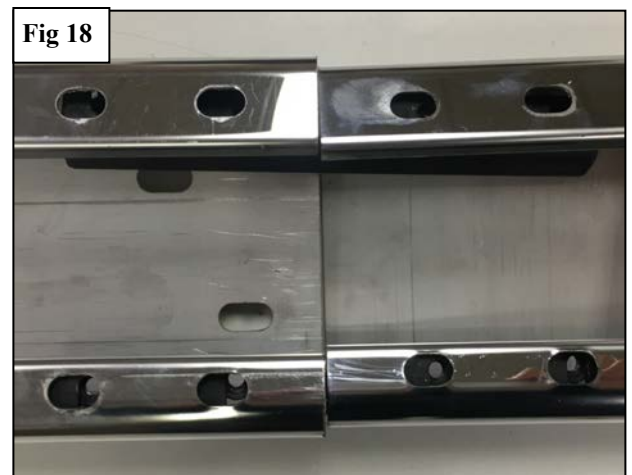

Figure 16

16. Obtain both sections of the Step Bar Assembly (1 or 2). Slide the Reinforcement Links (4 & 5) into both sides of the step bar sections. See **Figure 17**.

17. Line up the holes on the Step Bar sections with the holes on the Reinforcement Links (4 & 5). See **Figure 18**.



18. Place the supplied step pad into the holes to connect the two Step Bar sections (1 & 2). Place the supplied thread cutting nut on each of the plastic stems. See **Figures 19 and 20**.

Fig 19



Fig 20



19. Obtain the Link Plate (6) and secure it to the Step Bar Assembly (1 & 2) using the supplied M6 Hardware. See **Figure 21**.

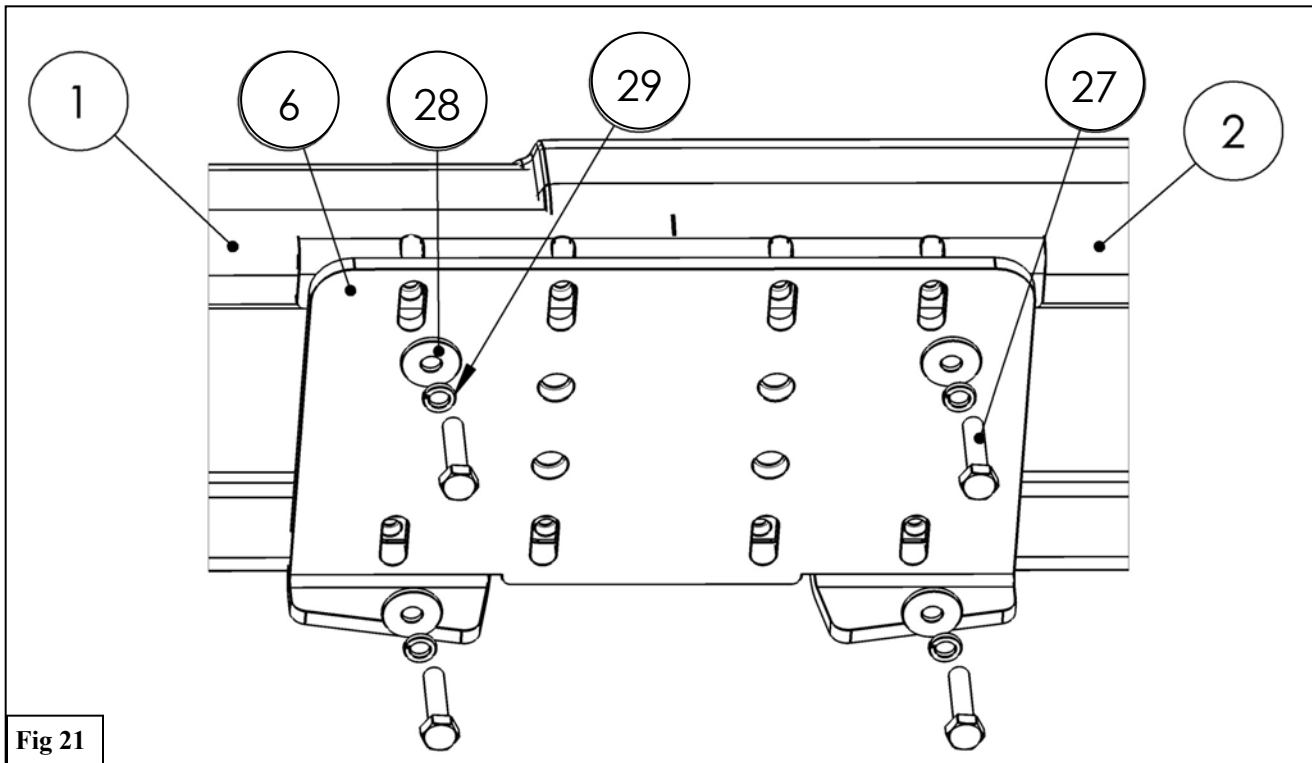
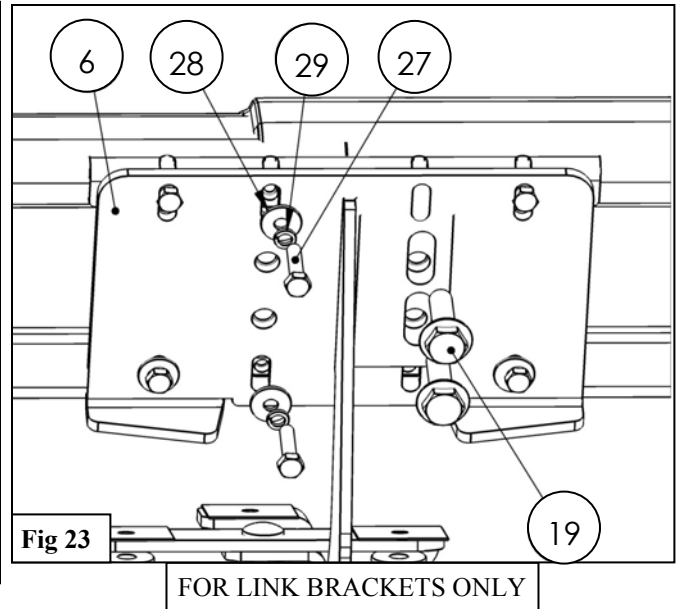
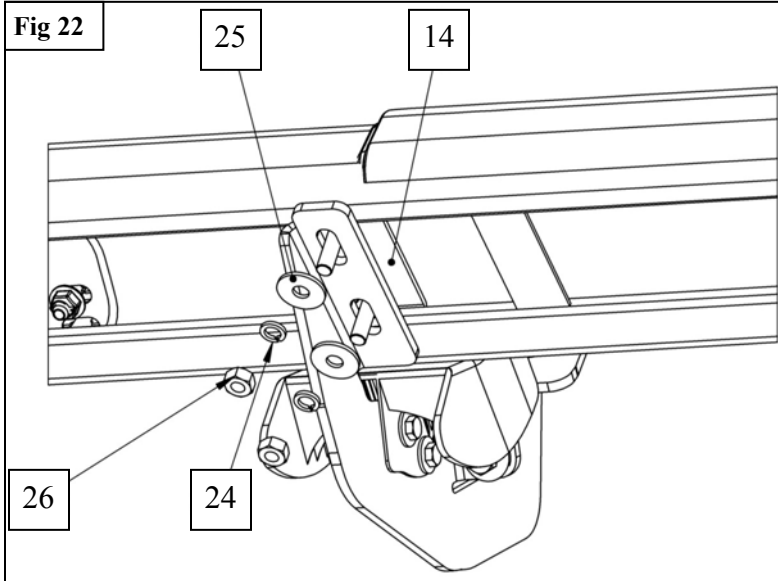

Fig 21

15. Installation of the step boards will utilize the supplied M8 hardware with Plate Adapters (14) for all brackets excluding the Link Brackets (7). The Link Brackets (7) will use the supplied M10 hardware. **See Figures 22 and 23.**

16. To minimize gap between step bars, and for a better fit of step pad around step bar. Make sure to align and adjust the step bars and brackets as needed, then fully tighten all hardware: M6 to 5 to 7 ft-lbs, M8 to 15-18 ft-lbs, M10 to 32-38 ft-lbs, and M12 to 52-60 ft-lbs.



DRIVER-GAS

Front →

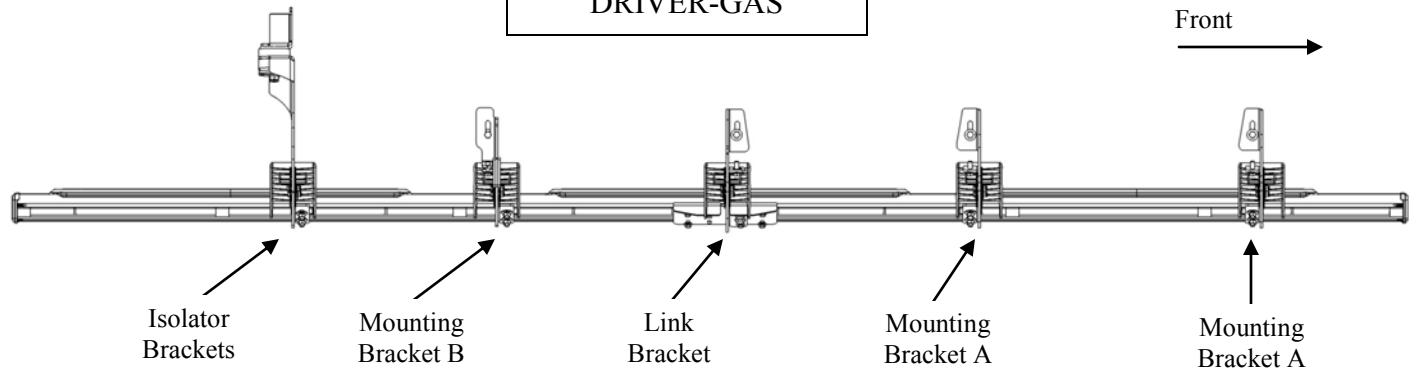

PASSENGER-GAS

← Front

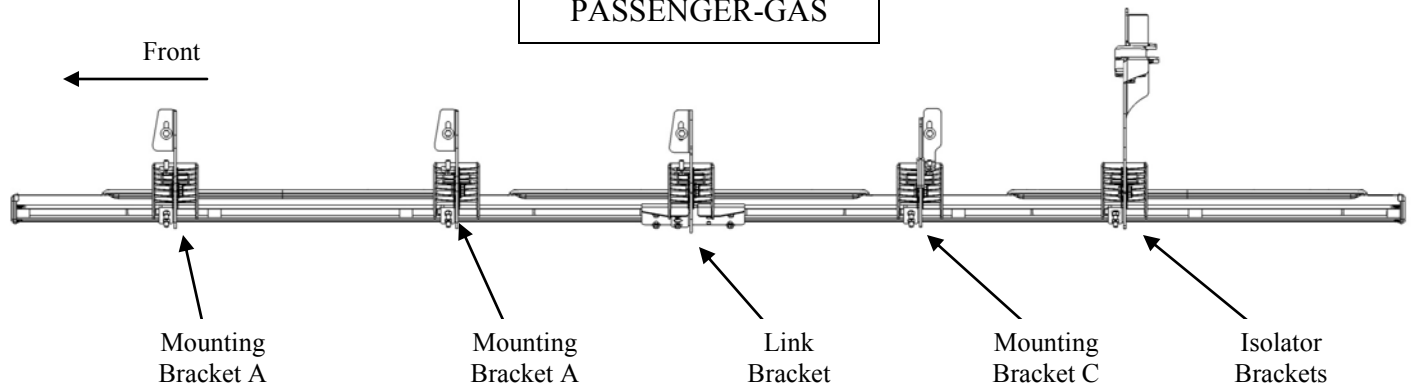

DRIVER-DIESEL

Front →

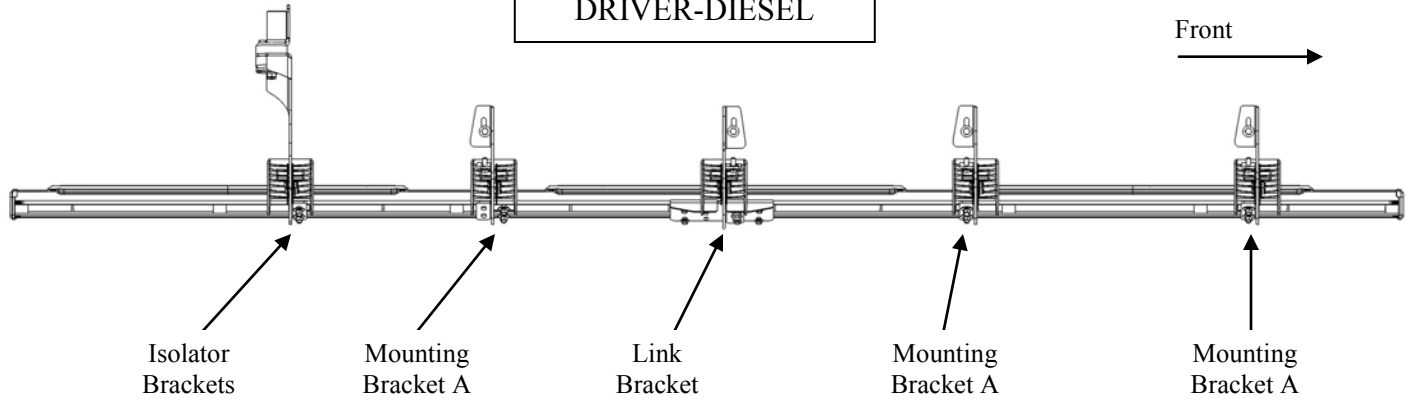

PASSENGER-DIESEL

← Front

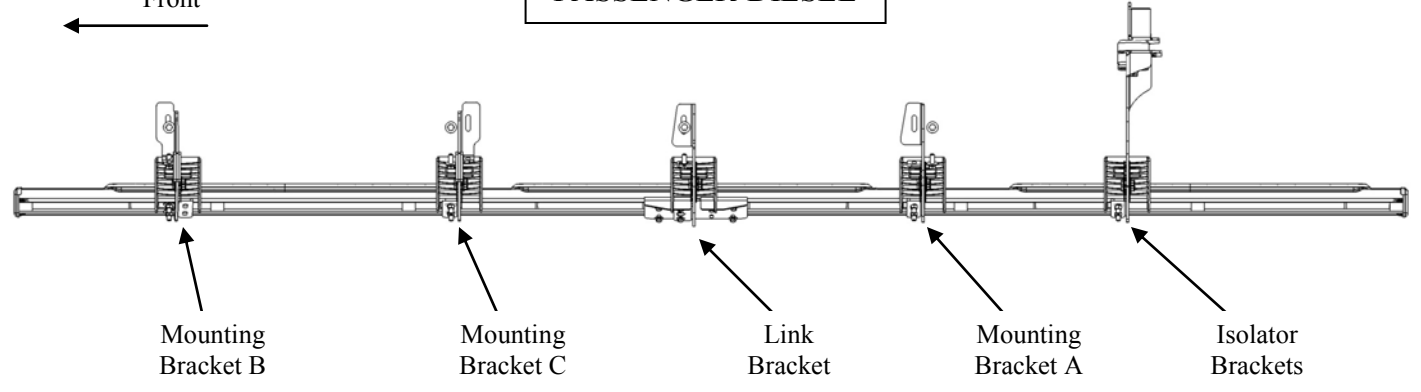

DIESEL EXHAUST FLUID TANK REMOVAL INSTRUCTIONS w/Diesel Power Train Only

Note: For 2017 models removal of the DEF tank is not necessary.

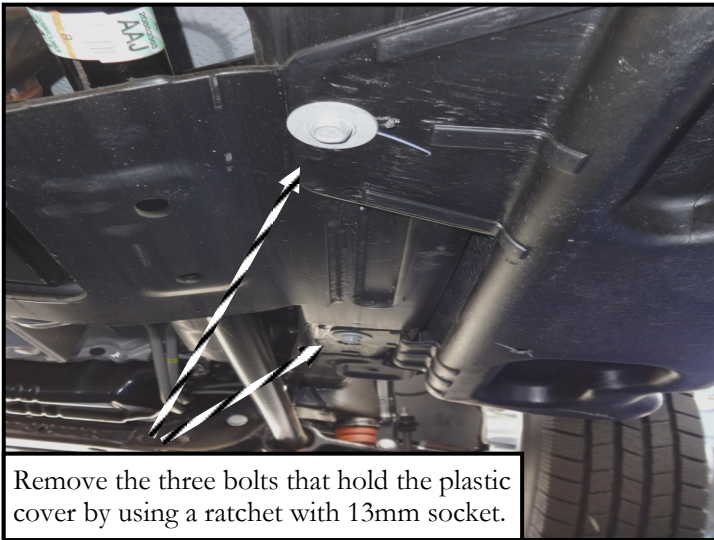

Remove the three bolts that hold the plastic cover by using a ratchet with 13mm socket.

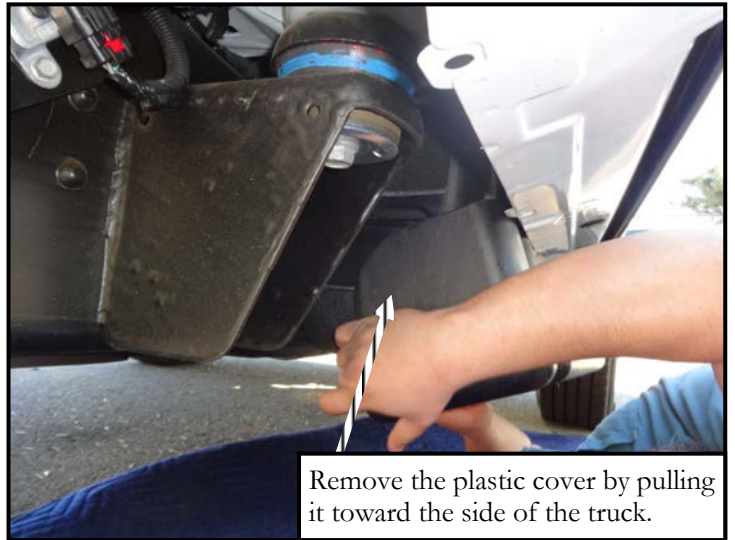

Remove the plastic cover by pulling it toward the side of the truck.

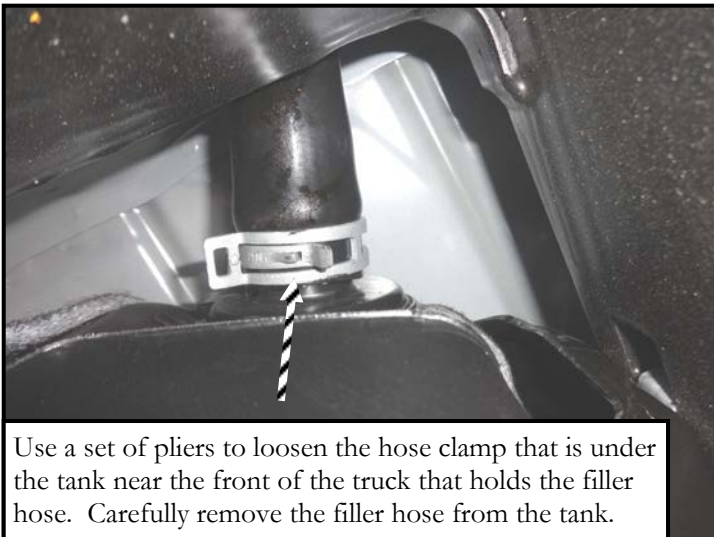

Use a set of pliers to loosen the hose clamp that is under the tank near the front of the truck that holds the filler hose. Carefully remove the filler hose from the tank.

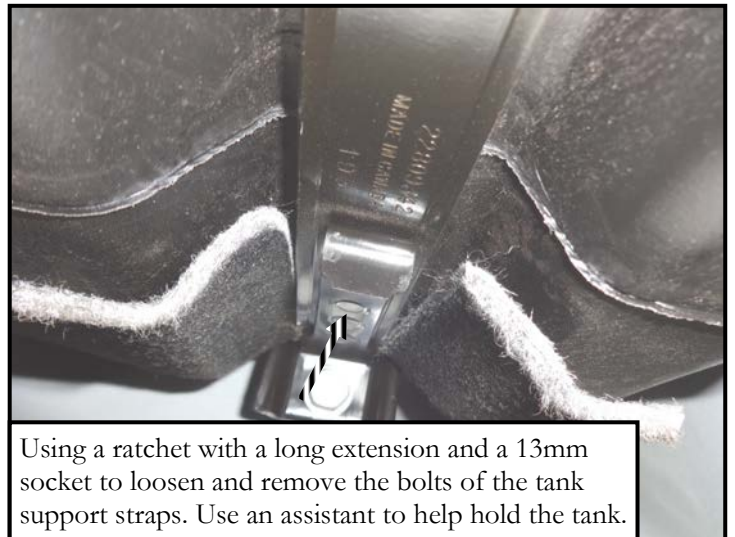

Using a ratchet with a long extension and a 13mm socket to loosen and remove the bolts of the tank support straps. Use an assistant to help hold the tank.

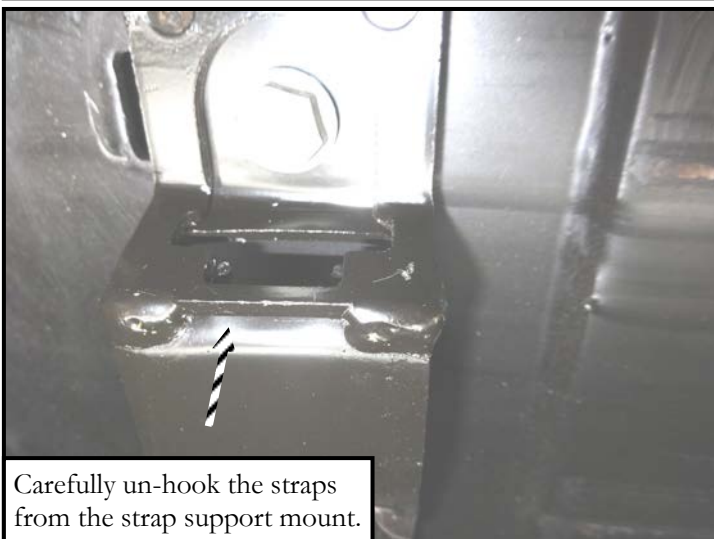

Carefully un-hook the straps from the strap support mount.

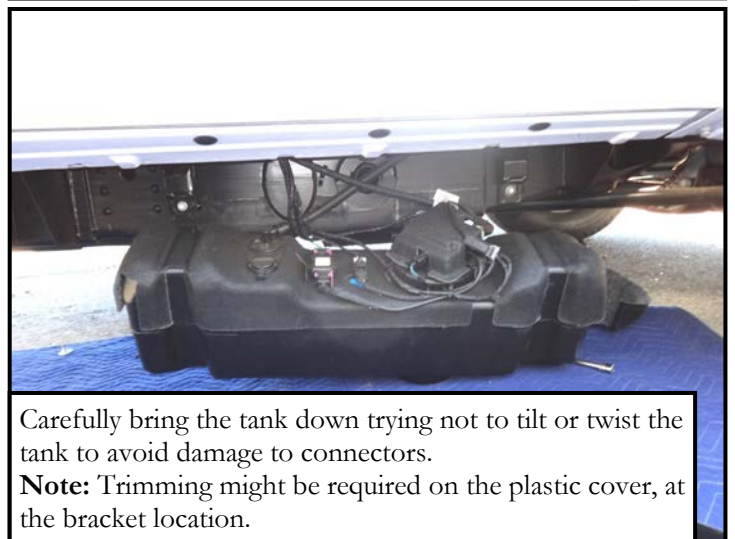

Carefully bring the tank down trying not to tilt or twist the tank to avoid damage to connectors.
Note: Trimming might be required on the plastic cover, at the bracket location.

INSTALLATION COMPLETE



Double Cab
6.5' Bed Shown



CARE INSTRUCTIONS

- REGULAR WAXING IS RECOMMENDED. DO NOT USE ANY TYPE OF POLISH OR WAX THAT MAY CONTAIN ABRASIVES
- STAINLESS STEEL PRODUCTS CAN BE CLEANED WITH MILD SOAP AND WATER. STAINLESS STEEL POLISH SHOULD BE USED TO POLISH SMALL SCRATCHES.
- GLOSS BLACK FINISHES SHOULD BE CLEANED WITH MILD SOAP AND WATER

WESTiN



WARNING



Failure to follow these instructions could lead to death, personal injury, and / or property damage.

Failure to follow these instructions could lead to death, personal injury, and / or property damage.

FASTENERS:

All Westin supplied fasteners must be utilized and installed in accordance with the installation instructions and apply torque to the specifications as defined. **DOUBLE CHECK ALL FASTENERS BEFORE INITIAL USE, AND PERIODICALLY IN THE FUTURE TO ENSURE PROPER FUNCTION AND SAFETY.**

DRILLING:

Most Westin products do not require drilling for installation. If drilling is defined as required, use caution when drilling a vehicle. **FAILURE TO REVIEW AN AREA TO BE DRILLED MAY RESULT IN PERSONAL INJURY AND/OR INJURY TO OTHERS AS WELL AS VEHICLE DAMAGE.**

EYE PROTECTION:

ALWAYS WEAR SAFETY GLASSES OR GOGGLES DURING THE INSTALLATION PROCESS TO AVOID PERSONAL INJURY.

MAXIMUM TOWING/CARRYING CAPACITY:

The Westin Receiver Hitches will have a visible tow rating label affixed directly on the product. User should never exceed the vehicle manufacturers maximum tow and weight rating regardless of the capacity of the hitch. **FAILURE TO FOLLOW THESE GUIDELINES WILL VOID THE WESTIN WARRANTY AND MAY RESULT IN PERSONAL INJURY AND/OR INJURY TO OTHERS AS WELL AS VEHICLE DAMAGE.**



Learn more about running boards and step bars we have.