



INSTALLATION INSTRUCTIONS

R5 MODULAR WHEEL TO WHEEL NERF STEP BARS

APPLICATION:

2007-2018 Chevy Silverado / GMC Sierra 1500 Crew Cab (5.5 ft. bed)

PART NUMBER:

28-534560, 28-534565

CONTENT

ITEM	QUANTITY	DESCRIPTION	TOOLS NEEDED
1	2	STEP BAR FRONT SECTION (1 DRIVER, 1 PASSENGER)	18MM SOCKET
2	2	STEP BAR REAR SECTION (1 DRIVER, 1 PASSENGER)	18MM WRENCH
3	2	STEP PAD	16MM WRENCH
4	2	REINFORCEMENT LINK TALL	16MM SOCKET
5	2	REINFORCEMENT LINK SHORT	13MM WRENCH
6	2	LINK PLATE	10MM SOCKET
7	2	LINK BRACKET (1 DRIVER, 1 PASSENGER)	10MM WRENCH
8	16	SELF THREADING NUTS	RATCHET
9	6	MOUNTING BRACKET	TORQUE WRENCH
10	2	TOP ISOLATOR BRACKET (1 DRIVER, 1 PASSENGER)	
11	2	BOTTOM ISOLATOR BRACKET (1 DRIVER, 1 PASSENGER)	
12	2	ISOLATOR KIT	
13	10	PLASTIC BRACKET COVER	
14	8	PLATE ADAPTER	
15	4	M10 BOLT PLATE	
16	4	M10 HEX NUT	
17	4	M10 SPLIT LOCK WASHER	
18	4	M10 FLAT WASHER	
19	4	M10 HEX HEAD FLANGE BOLT (Black Zinc)	
20	2	M10 FISH WIRE	
21	16	M8 U-NUT	
22	4	M8 RIV-NUT	
23	18	M8 HEX HEAD CAP SCREW	
24	34	M8 SPLIT LOCK WASHER (16 Black Zinc)	
25	34	M8 FLAT WASHER (16 Black Zinc)	
26	16	M8 HEX NUT (Black Zinc)	
27	32	M6 HEX HEAD CAP SCREW (12 Black Zinc)	
28	52	M6 FLAT WASHER (12 Black Zinc)	
29	12	M6 SPLIT LOCK WASHER (Black Zinc)	
30	20	M6 NYLOCK NUT	
31	1	UNIVERSAL RIV-CERT TOOL	

ANTI-SEIZE LUBRICANT MUST BE USED ON ALL STAINLESS STEEL FASTENERS TO PREVENT THREAD DAMAGE AND GALLING



ITEM 1

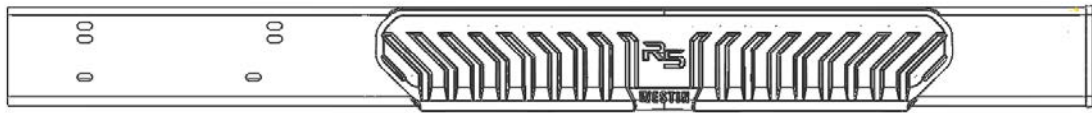

Note markings on board

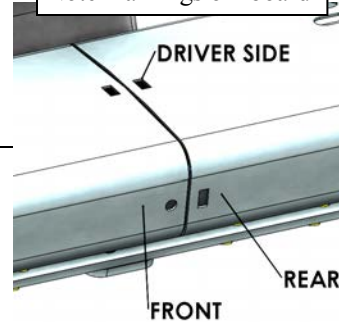

ITEM 2

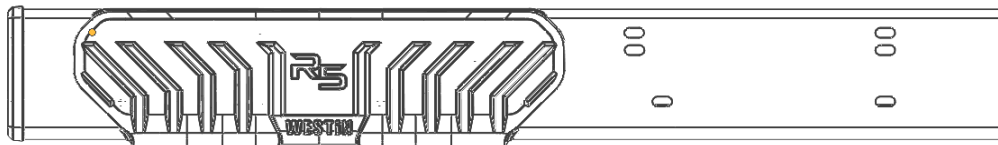

ITEM 3

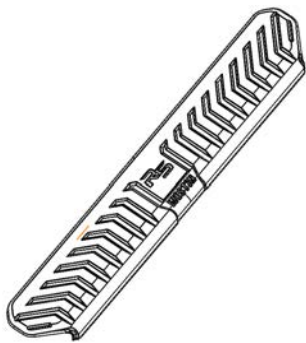

ITEM 4

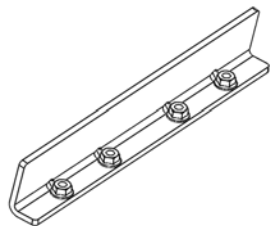

ITEM 5

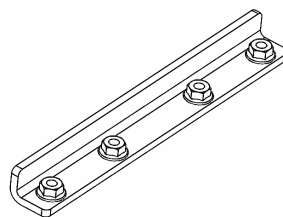

ITEM 6

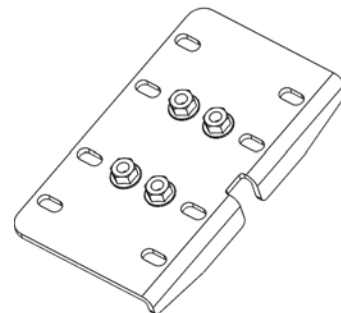

ITEM 7

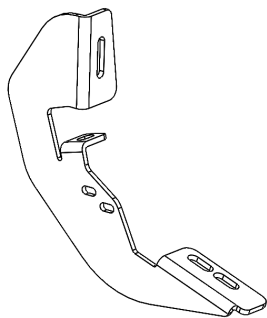

ITEM 9

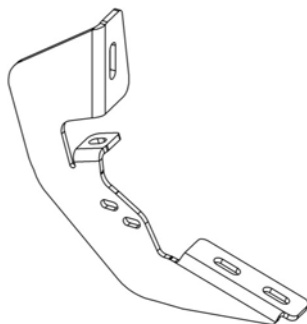

ITEM 10

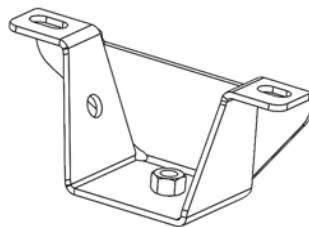

ITEM 11

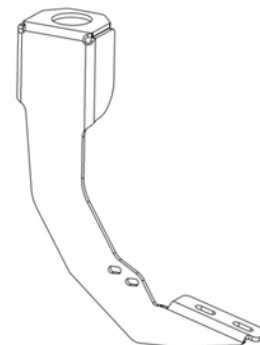

ITEM 12

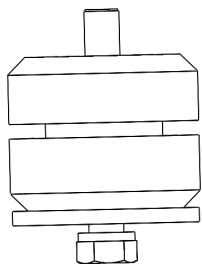

ITEM 13

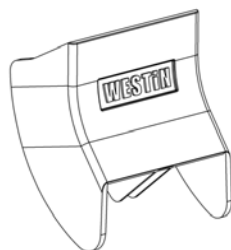

ITEM 14

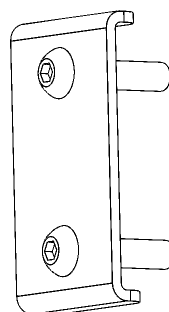

PASSENGER SIDE ITEMS SHOWN

PROCEDURE

1. Remove contents from box, verify if all parts listed are present and free from damage.

Carefully read and understand all instructions before attempting installation.

Failure to identify damage before installation could lead to a rejection of any claim.

2. Starting on the driver side, remove the rubber plugs located on the rocker panel at each mounting location. See **Figure 1**.
3. **For models with welded nuts:** At each bracket mounting location on the pinch weld there should either be a welded factory nut or a hole. If there is a factory welded nut present, then the M8 U-Nut Clip (Item 21) will not be used at that location. See **Figure 2** for the factory welded nut.

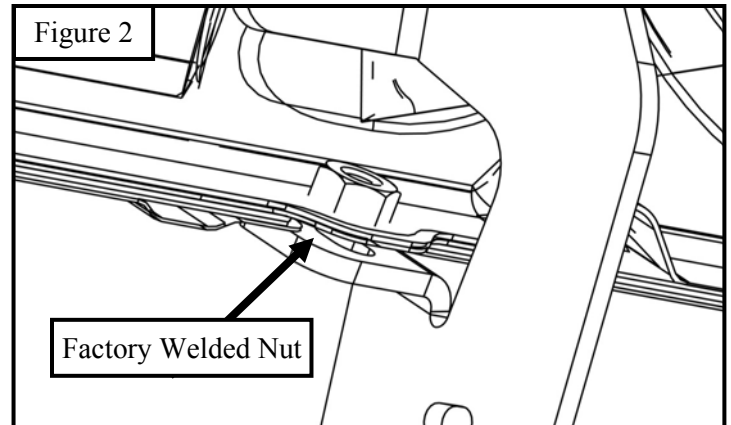
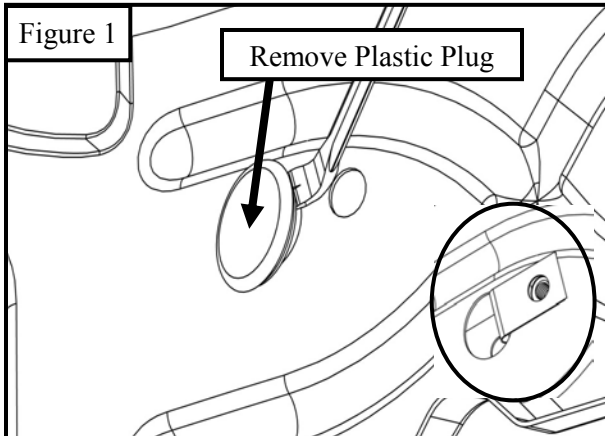

4. Insert (1) M8 u-nut clip (Item 21) into the hole where the rubber plug was removed. Clip (1) M8 u-nut clip onto pinch weld if no factory welded nut is present. Locate (1) Mounting Bracket A (Item 9) and loosely secure it to the rocker panel using the provided hardware: (2) M8 hex head bolt, (2) M8 flat washer, and (2) M8 lock washer. See **Figure 3**.
5. Repeat **Step 4**, moving one location back on the vehicle.



Fig 3

6. Install the Link Bracket (Item 7) using the supplied hardware: (2) M8 hex head bolt long, (2) M8 flat washer, and (2) M8 lock washer. See **Figure 4**.

Fig 4



Fig 5

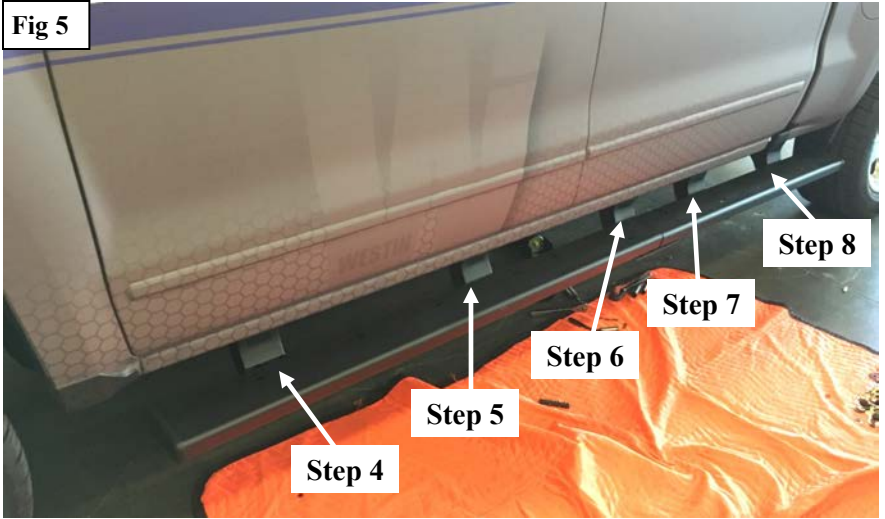

7. Repeat **Step 4**, moving one location back on the vehicle.

8. Locate Bed Rail underneath the truck at the front of the bed. If the open end of the rail has an existing bracket remove the attached factory M8 bolt. There will be an open hole towards the inside of the truck where the M10 bolt plate will go by use of fish wire (Item 20). Loosely install Top Isolator Bracket (Item 10) with supplied M8 and M10 hardware. See **Fig 5-7**.
9. If there are only 2 existing holes insert supplied M10 bolt plates (Item 15) through the existing holes. Then Install Top Isolator Bracket (Item 10) with supplied M10 hardware. See **Figures 7, 8, and 9**.

Fig 6

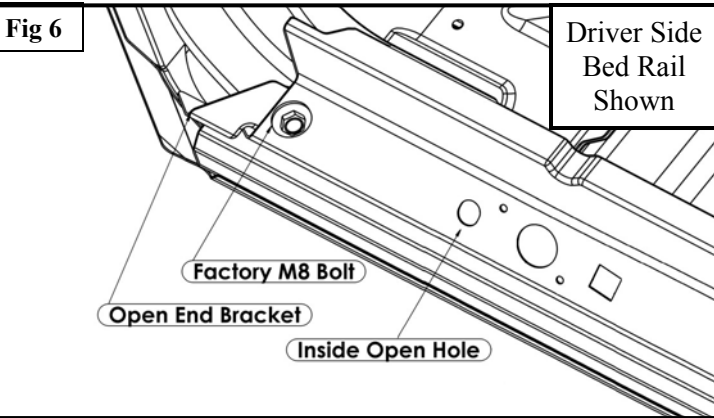

Fig 7

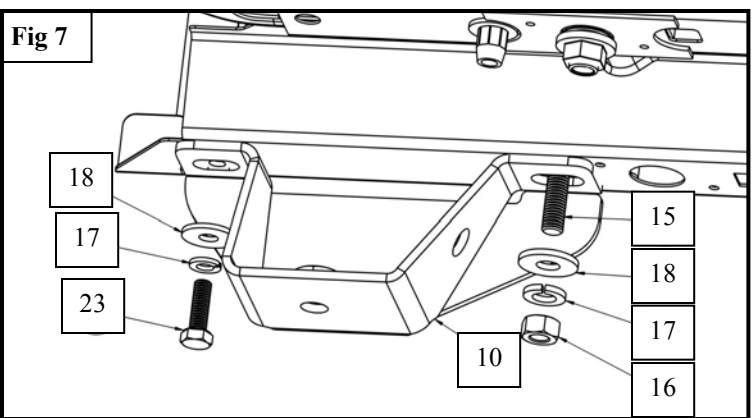

Fig 8

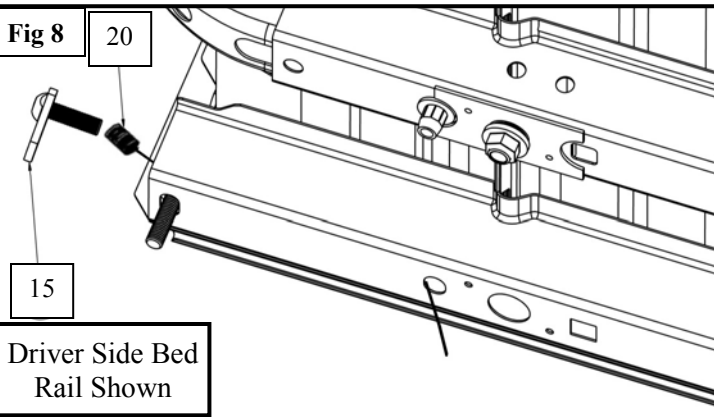
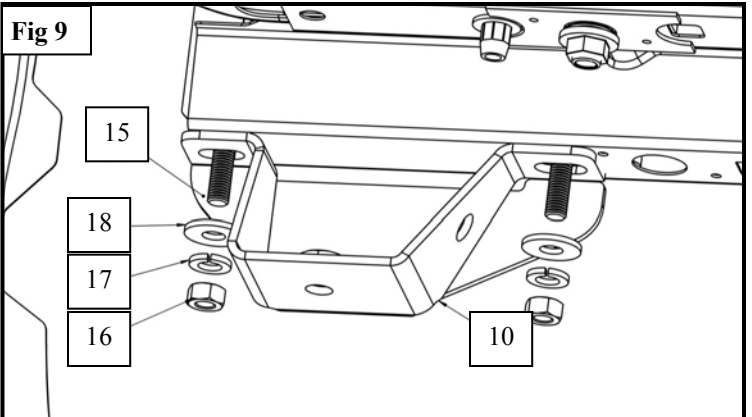
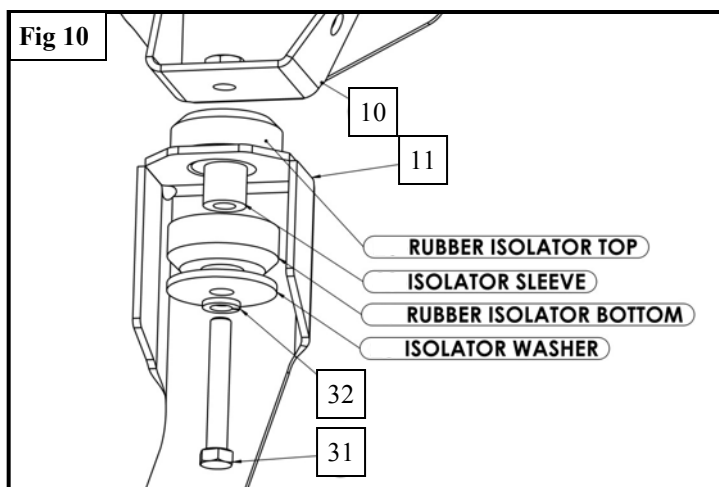

Fig 9



10. Install Bottom Isolator Bracket (Item 11) to previously mounted Top Isolator Bracket (Item 10) with supplied Isolator Kit (Item 12) and M12 Hardware. Assemble loosely. See **Figure 10**.



11. Obtain both sections of the Step Bar Assembly (1 or 2). Slide the Reinforcement Links (4 & 5) into both sides of the step bar sections. See **Figure 11**.

12. Line up the holes on the Step Bar sections with the holes on the Reinforcement Links (4 & 5). See **Figure 12**.



13. Place the supplied step pad into the holes to connect the two Step Bar sections (1 & 2). Place the supplied thread cutting nut on each of the plastic stems. Tighten until nut reaches metal and feels firm in place. **See Figures 13 and 14.**

Fig 13

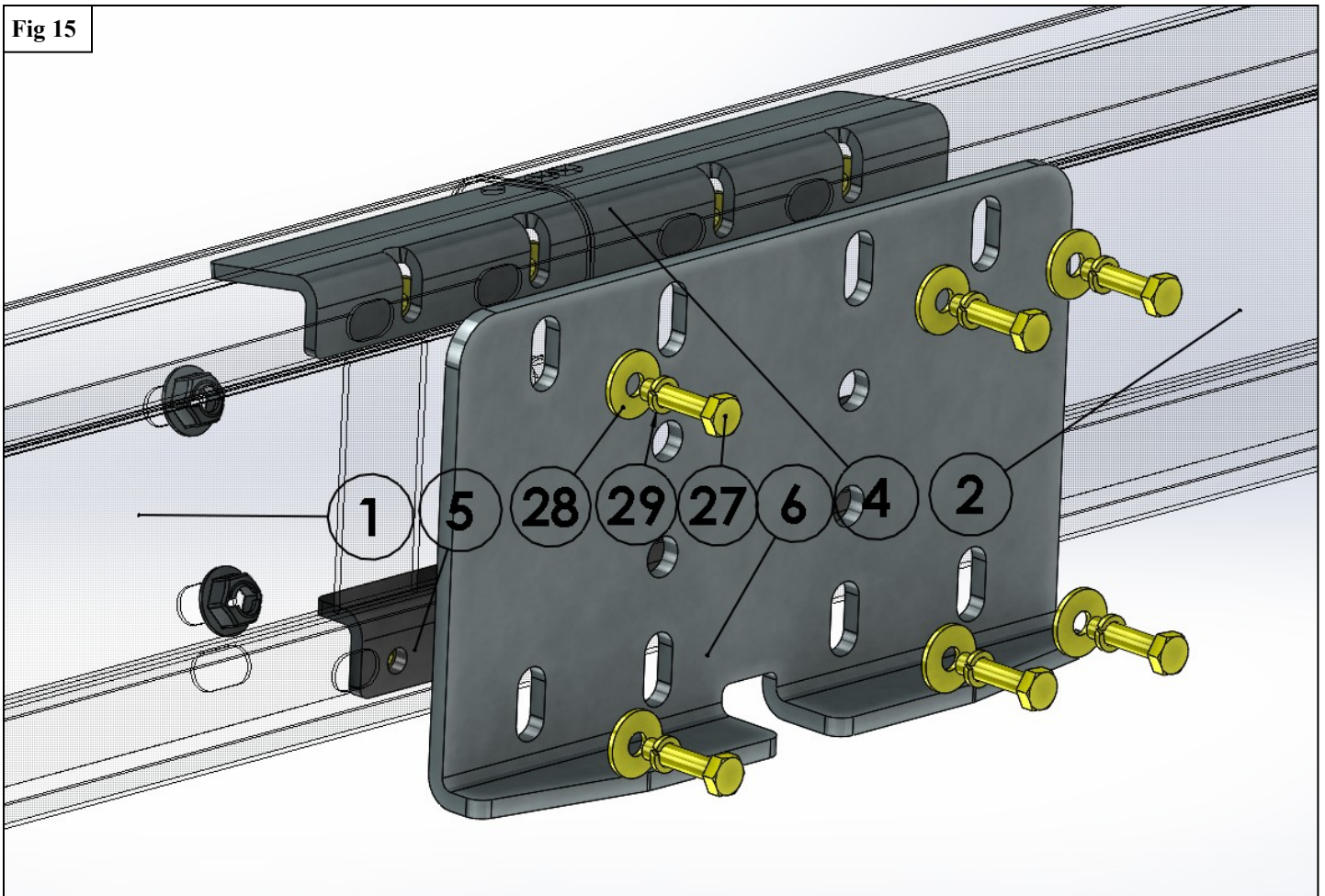

Fig 14



14. Obtain the Link Plate (6) and secure it to the Step Bar Assembly (1 & 2) using the supplied black M6 Hardware. **See Figure 15.**

Fig 15



15. Installation of the step boards will utilize the supplied black M8 hardware with Plate Adapters (14) for all brackets excluding the Link Brackets (7). The Link Brackets (7) will use the supplied black M10 hardware. **See Figures 16 and 17.**

16. To minimize gap between step bars, and for a better fit of step pad around step bar. Make sure to align and adjust the step bars and brackets as needed, then fully tighten all hardware: M6 to 5 to 7 ft-lbs, M8 to 15-18 ft-lbs, M10 to 32-38 ft-lbs, and M12 to 52-60 ft-lbs.

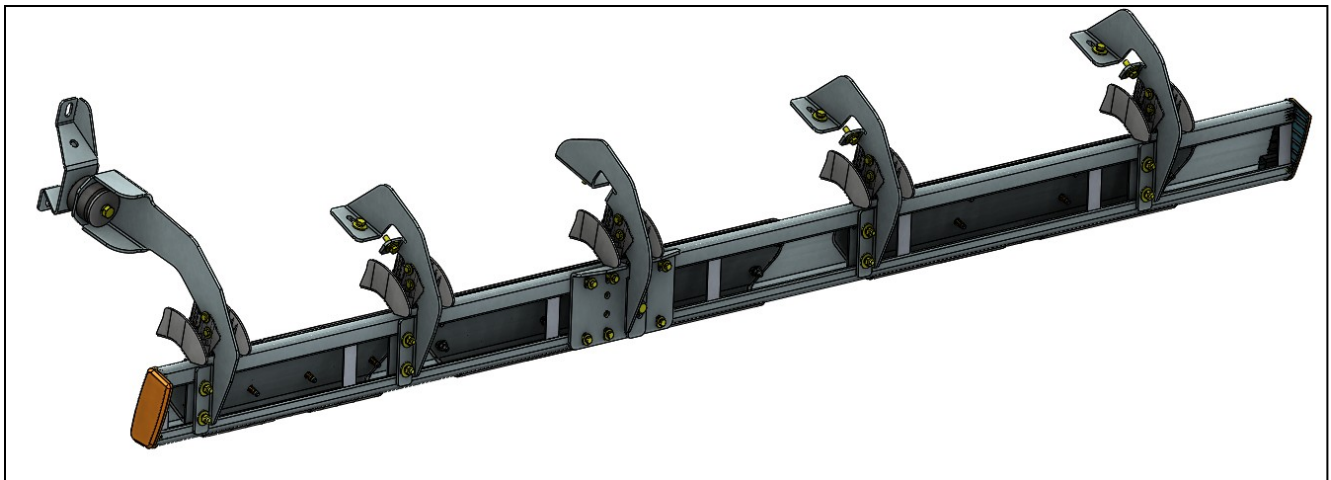
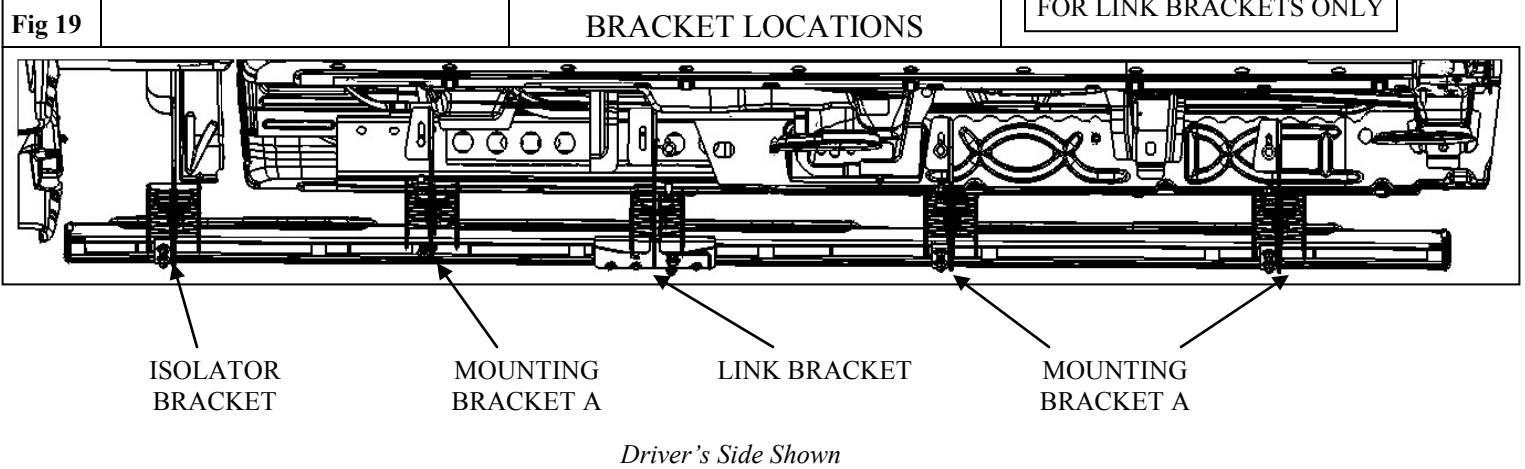
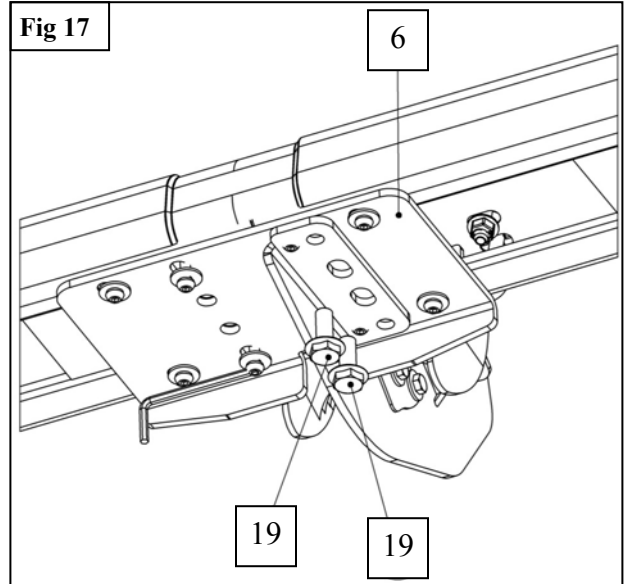
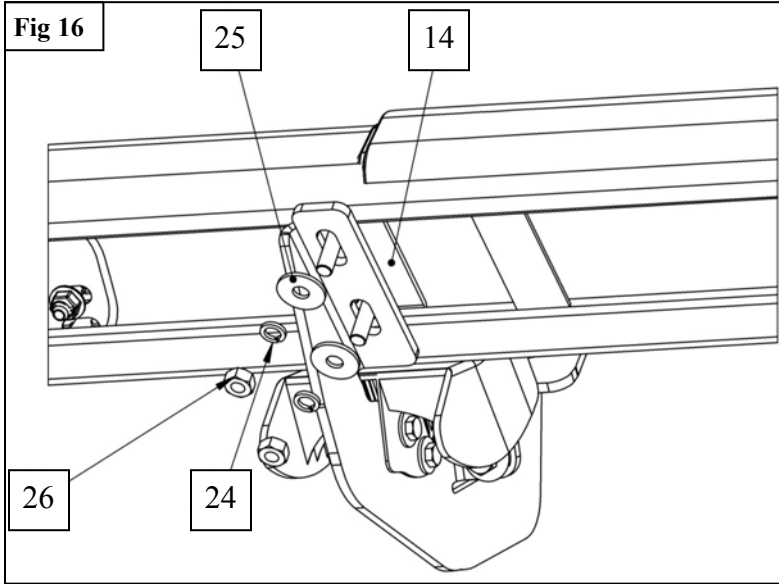

INSTALLATION COMPLETE



Double Cab
6.5' Bed Shown

CARE INSTRUCTIONS

- REGULAR WAXING IS RECOMMENDED. DO NOT USE ANY TYPE OF POLISH OR WAX THAT MAY CONTAIN ABRASIVES
- STAINLESS STEEL PRODUCTS CAN BE CLEANED WITH MILD SOAP AND WATER. STAINLESS STEEL POLISH SHOULD BE USED TO POLISH SMALL SCRATCHES.
- GLOSS BLACK FINISHES SHOULD BE CLEANED WITH MILD SOAP AND WATER



WARNING



Failure to follow these instructions could lead to death, personal injury, and / or property damage.

Failure to follow these instructions could lead to death, personal injury, and / or property damage.

FASTENERS:

All Westin supplied fasteners must be utilized and installed in accordance with the installation instructions and apply torque to the specifications as defined. **DOUBLE CHECK ALL FASTENERS BEFORE INITIAL USE, AND PERIODICALLY IN THE FUTURE TO ENSURE PROPER FUNCTION AND SAFETY.**

DRILLING:

Most Westin products do not require drilling for installation. If drilling is defined as required, use caution when drilling a vehicle. **FAILURE TO REVIEW AN AREA TO BE DRILLED MAY RESULT IN PERSONAL INJURY AND/OR INJURY TO OTHERS AS WELL AS VEHICLE DAMAGE.**

EYE PROTECTION:

ALWAYS WEAR SAFETY GLASSES OR GOGGLES DURING THE INSTALLATION PROCESS TO AVOID PERSONAL INJURY.

MAXIMUM TOWING/CARRYING CAPACITY:

The Westin Receiver Hitches will have a visible tow rating label affixed directly on the product. User should never exceed the vehicle manufacturers maximum tow and weight rating regardless of the capacity of the hitch. **FAILURE TO FOLLOW THESE GUIDELINES WILL VOID THE WESTIN WARRANTY AND MAY RESULT IN PERSONAL INJURY AND/OR INJURY TO OTHERS AS WELL AS VEHICLE DAMAGE.**



Learn more about running boards and step bars we have.