

INSTALLATION INSTRUCTIONS

R5 NERF STEP BAR



APPLICATION:

2019 Chevy Silverado/GMC Sierra 1500 Crew Cab & Double Cab (Excl. 2019 Silverado LD/Sierra 1500 Limited)

PART NUMBER:

28-51270, 28-51275, 28-51260, 28-51265

CONTENT			
ITEM	QUANTITY	DESCRIPTION	TOOLS NEEDED
1,2	2	STEP BAR ASSEMBLY (1 DRIVER, 1 PASSENGER)	10MM SOCKET
3	6	MOUNTING BRACKET	10MM WRENCH
4	6	PLASTIC COVER BRACKET	13MM SOCKET
5	6	PLATE ADAPTER (ONLY FOR 28-51270)	RATCHET
6	1	HEX KEY TOOL	TORQUE WRENCH
7	12	M8 SQUARE HEAD BOLT (BLACK ZINC) (ONLY FOR 28-51275)	
8	12	M8 HEX NUT (BLACK ZINC FOR 28-51270 ;YELLOW ZINC FOR 28-51275)	
9	12	M8 FLAT WASHER (BLACK ZINC FOR 28-51270 ;YELLOW ZINC FOR 28-51275)	
10	12	M8 SPLIT LOCK WASHER (BLACK ZINC FOR 28-51270 ;YELLOW ZINC FOR 28-51275)	
11	12	M8 HEX HEAD SCREW	
12	12	M6 HEX HEAD CAP SCREW	
13	24	M6 FLAT WASHER	
14	12	M6 NYLON NUT	
15	12	M8 FLAT WASHER (YELLOW ZINC)	
16	12	M8 SPLIT LOCK WASHER (YELLOW ZINC)	

ANTI-SEIZE LUBRICANT MUST BE USED ON ALL STAINLESS STEEL FASTENERS TO PREVENT THREAD DAMAGE AND GALLING

ITEM 1

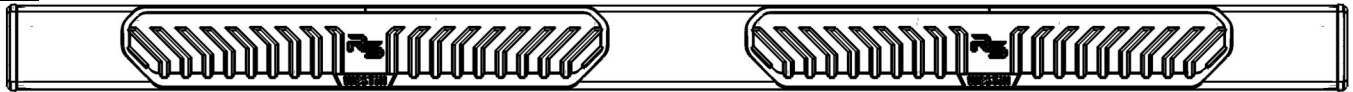

Crew Cab shown; Double Cab will be shorter

ITEM 3

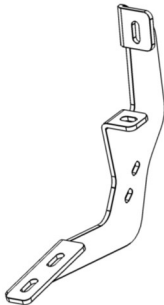

ITEM 4

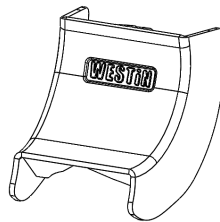

ITEM 5

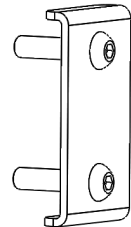

only for 28-51270



PROCEDURE

1. Remove contents from box, verify if all parts listed are present and free from damage.

Carefully read and understand all instructions before attempting installation.

Failure to identify damage before installation could lead to a rejection of any claim.

2. Starting on the driver side, remove the rubber plugs located on the rocker panel at each mounting location. See **Figure 1**.
3. **For models with threaded holes:** At each bracket mounting location on the rocker panel there should be a welded factory nut.



Figure 1

4. Locate (1) Mounting Bracket (Item 3) and loosely secure it to the rocker panel using the provided hardware: (2) M8 hex head bolt, (2) M8 flat washer, and (2) M8 lock washer. See **Figure 2**.
5. Repeat **Step 4** for all remaining bracket mounting locations.

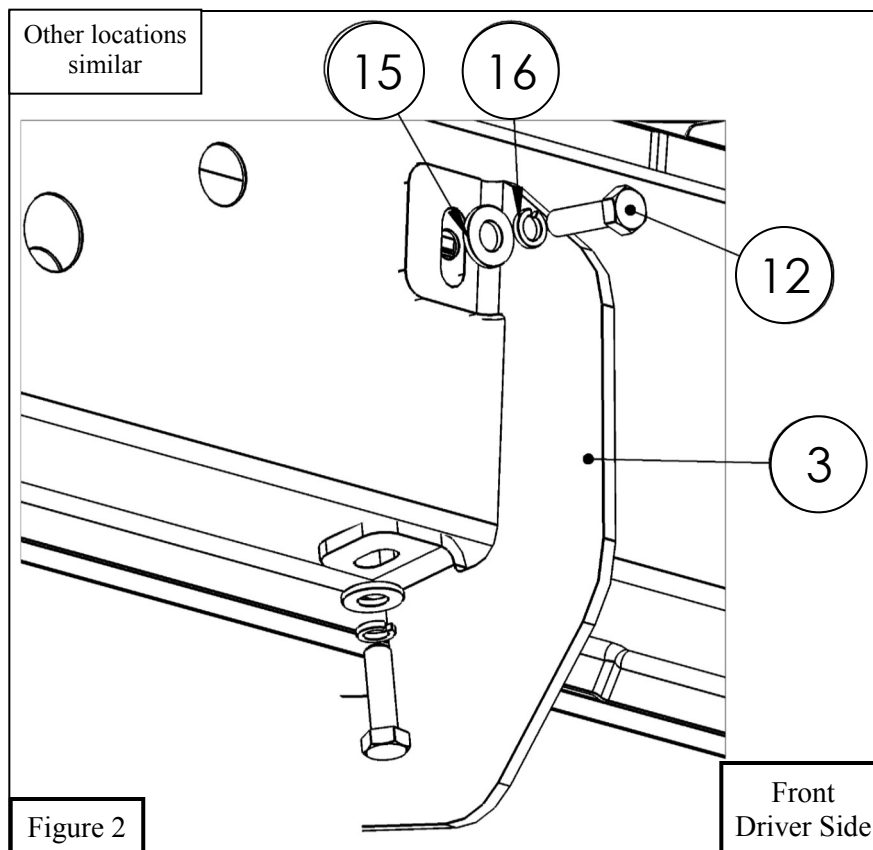
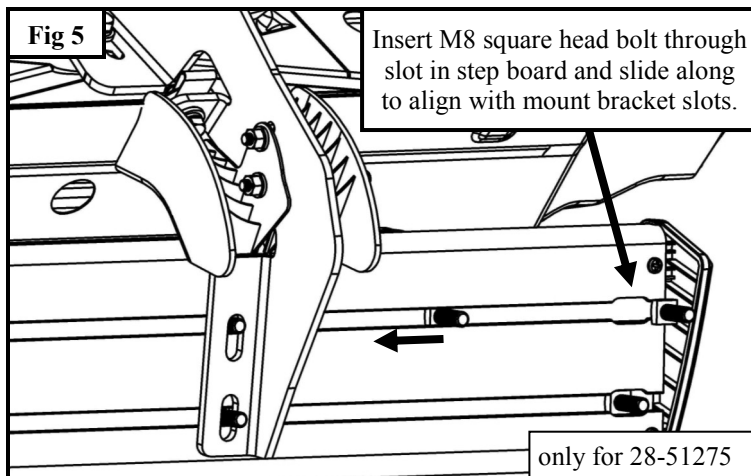
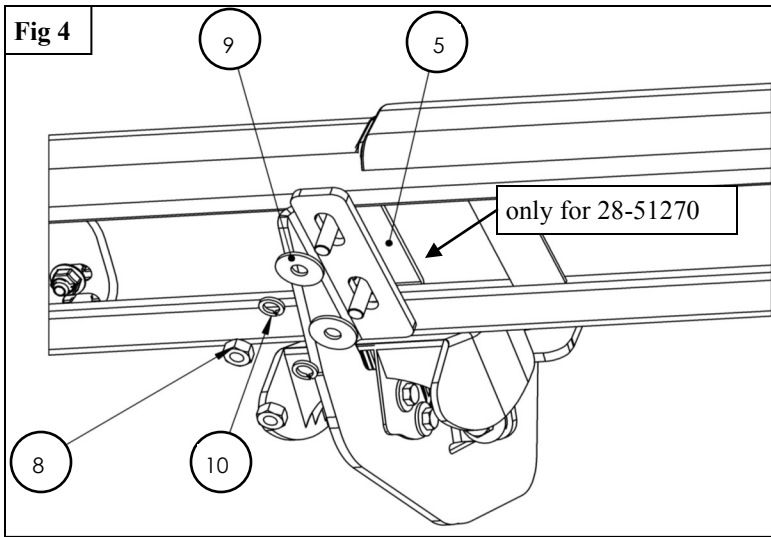
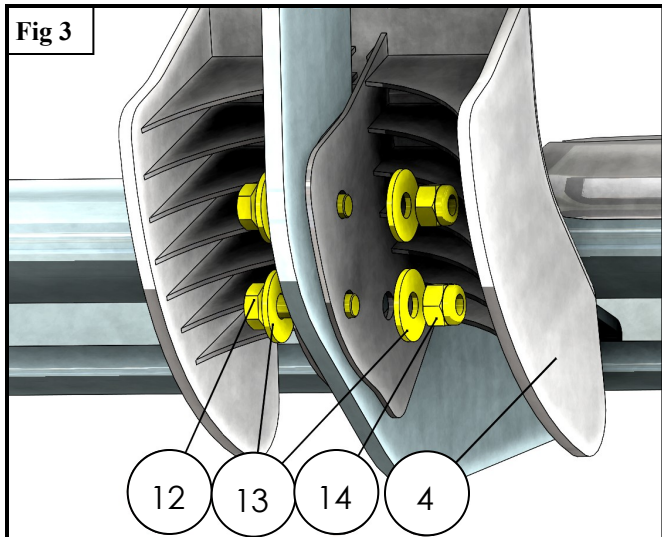
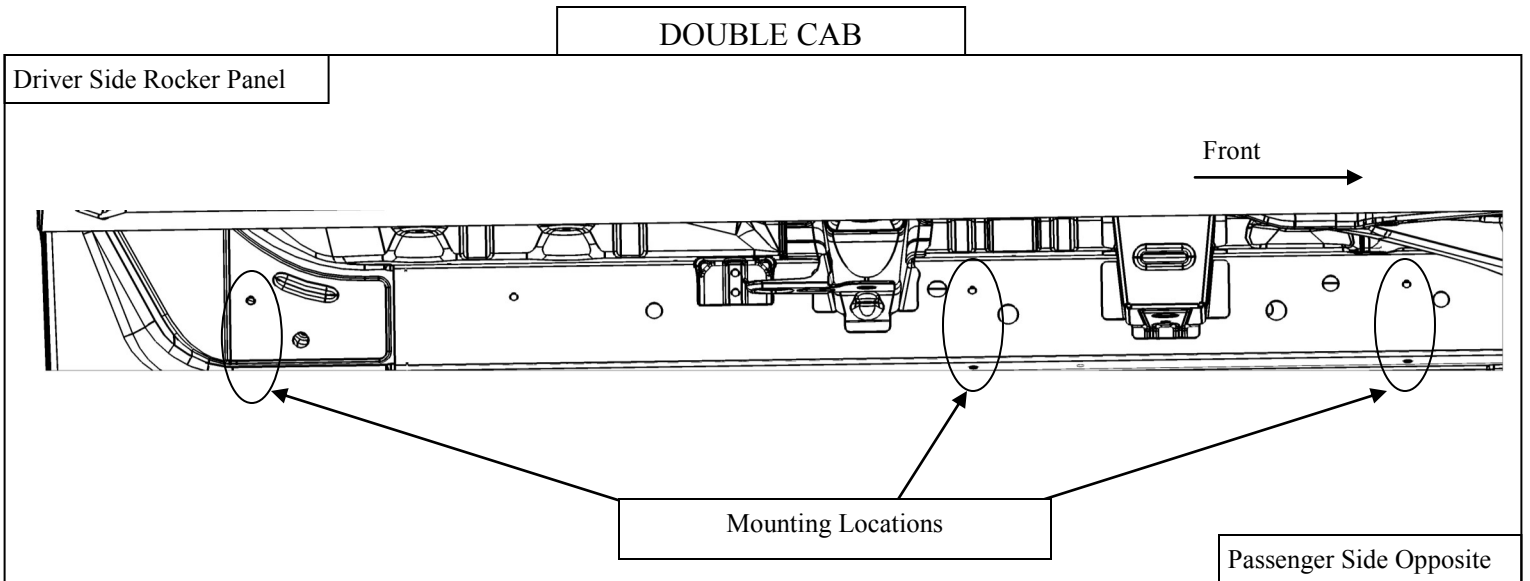
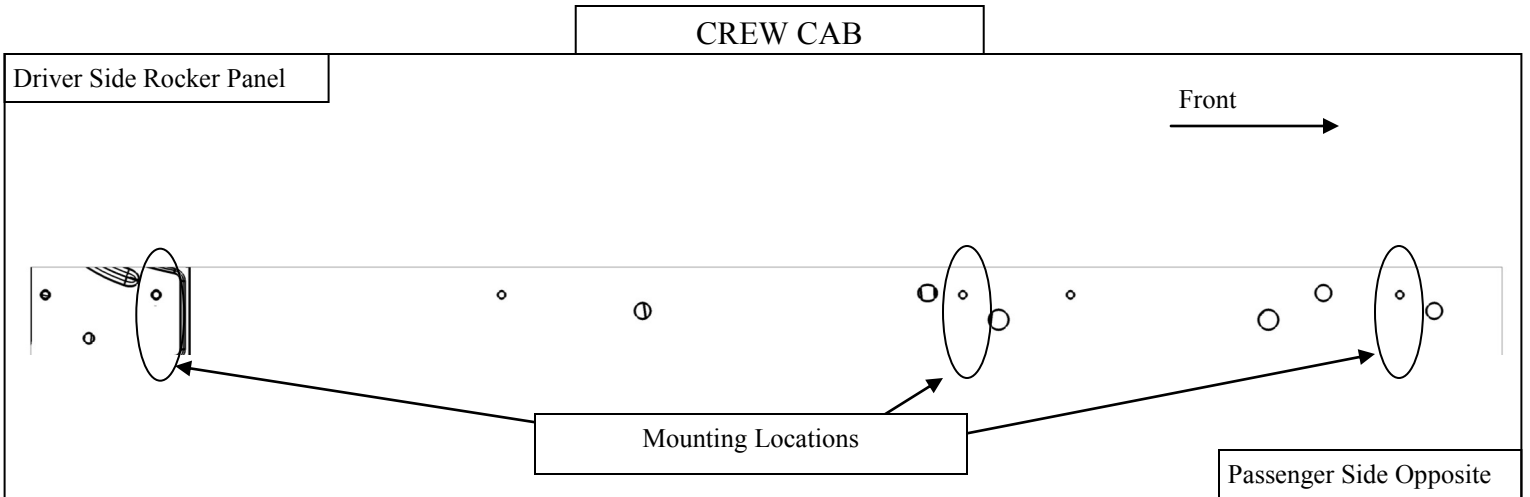

Figure 2

Front
Driver Side

8. Secure the Plastic Bracket Covers (4) to the Mounting Brackets using the supplied M6 Hardware. See **Figure 3**.
9. Fasten step bars respectively to either side using the M8 hardware provided with the step bars. See **Figures 4 & 5**.
10. Align and adjust the step bars as needed and fully tighten all hardware. Torque all M6 fasteners to 5-7 ft-lbs and all M8 fasteners to 15-18 ft-lbs.





INSTALLATION COMPLETE



Crew Cab Model Shown

WESTIN



WARNING



Failure to follow these instructions could lead to death, personal injury, and / or property damage.

Failure to follow these instructions could lead to death, personal injury, and / or property damage.

FASTENERS:

All Westin supplied fasteners must be utilized and installed in accordance with the installation instructions and apply torque to the specifications as defined. **DOUBLE CHECK ALL FASTENERS BEFORE INITIAL USE, AND PERIODICALLY IN THE FUTURE TO ENSURE PROPER FUNCTION AND SAFETY.**

DRILLING:

Most Westin products do not require drilling for installation. If drilling is defined as required, use caution when drilling a vehicle. **FAILURE TO REVIEW AN AREA TO BE DRILLED MAY RESULT IN PERSONAL INJURY AND/OR INJURY TO OTHERS AS WELL AS VEHICLE DAMAGE.**

EYE PROTECTION:

ALWAYS WEAR SAFETY GLASSES OR GOGGLES DURING THE INSTALLATION PROCESS TO AVOID PERSONAL INJURY.

MAXIMUM TOWING/CARRYING CAPACITY: (if applicable)

The Westin Receiver Hitches will have a visible tow rating label affixed directly on the product. User should never exceed the vehicle manufacturers maximum tow and weight rating regardless of the capacity of the hitch. **FAILURE TO FOLLOW THESE GUIDELINES WILL VOID THE WESTIN WARRANTY AND MAY RESULT IN PERSONAL INJURY AND/OR INJURY TO OTHERS AS WELL AS VEHICLE DAMAGE.**



Learn more about running boards and step bars we have.