

INSTALLATION INSTRUCTIONS

R5 Nerf Step Bar



APPLICATION:
2020-2021 Ford Explorer
PART NUMBER:
28-51250, 28-51255

CONTENT			
ITEM	QUANTITY	DESCRIPTION	TOOLS NEEDED
1	1	DRIVER STEP BAR	13MM SOCKET
2	1	PASSENGER STEP BAR	RATCHET
3	6	MOUNT BRACKET	TORQUE WRENCH
4	6	M10 HEX HEAD BOLT (YELLOW ZINC)	15MM SOCKET
5	6	M10 SPLIT LOCK WASHER (YELLOW ZINC)	
6	6	M10 FLAT WASHER (YELLOW ZINC)	
7	6	M10 SERRATED FLANGE NUT (YELLOW ZINC)	
8	6	M8 HEX HEAD BOLT (YELLOW ZINC)	
9	6	M8 SPLIT LOCK WASHER (YELLOW ZINC)	
10	6	M8 FLAT WASHER (YELLOW ZINC)	
11	12	M6 HEX HEAD BOLT (YELLOW ZINC)	
12	24	M6 FLAT WASHER (YELLOW ZINC)	
13	12	M6 NYLOCK NUT (YELLOW ZINC)	
14	12	M8 SQUARE HEAD BOLT (BLACK ZINC) (ONLY FOR 28-51255)	
15	12	M8 SPLIT LOCK WASHER (BLACK ZINC)	
16	12	M8 FLAT WASHER (BLACK ZINC)	
17	12	M8 HEX NUT (BLACK ZINC)	
18	6	M8 U-CLIP	
19	6	BRACKET COVER	
20	6	PLATE ADAPTER (ONLY FOR 28-51255)	

ANTI-SEIZE LUBRICANT MUST BE USED ON ALL STAINLESS STEEL FASTENERS TO PREVENT THREAD DAMAGE AND GALLING

ITEM 1 (DRIVER SIDE STEP BAR)

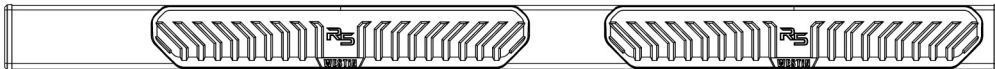

ITEM 2 (PASSENGER SIDE STEP BAR)

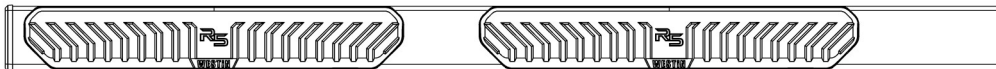

ITEM 3 (MOUNT BRACKET)

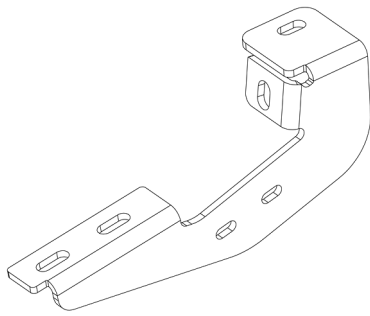

ITEM 19 (BRACKET COVER)

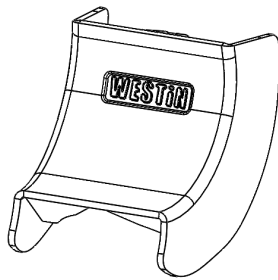

ITEM 20 (PLATE ADAPTER)

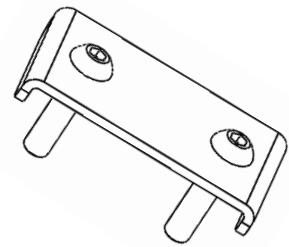

only for 28-51270

PROCEDURE

1. Remove contents from box, verify if all parts listed are present and free from damage. Carefully read and understand all instructions before attempting installation. **Failure to identify damage before installation could lead to a rejection of any claim.**

Driver Side Bracket Installation

2. Locate the rocker panel underneath the driver side of the vehicle. At each bracket location, install one M8 U-clip on the top side and one M10 serrated flange nut on the front side of the rocker panel (farthest hole **back**). *Note: The nut will fit between the rocker panel and the plastic cladding.* See Figure 1

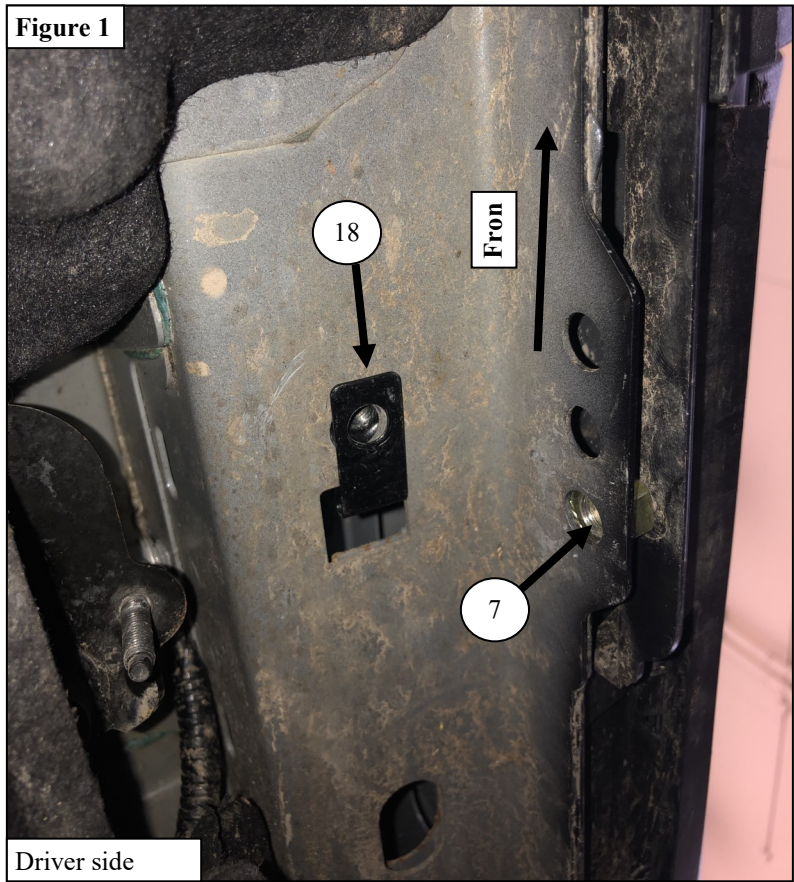

3. At each location, using M8 and M10 hardware, loosely assemble the Mount Brackets (item 3) to the rocker panel.
See Figures 2 and 3.

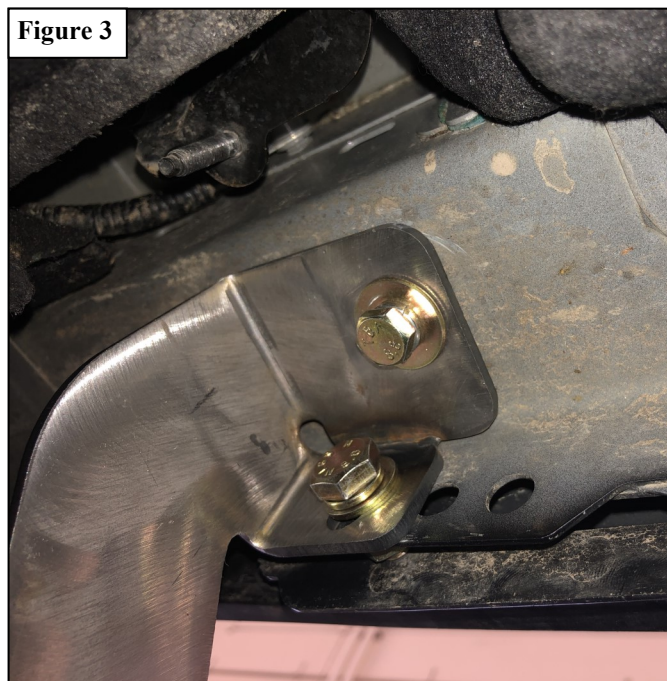
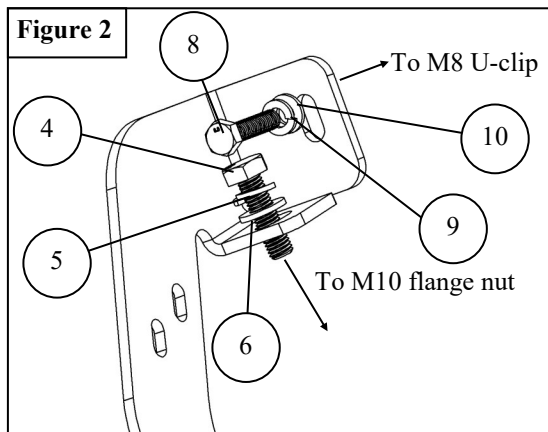

Passenger Side Bracket Installation

4. Locate the rocker panel underneath the passenger side of the vehicle. At each bracket location, install one M8 U-clip on the top side and one M10 serrated flange nut on the front side of the rocker panel (farthest hole **forward**). *Note: The nut will fit between the rocker panel and the plastic cladding.*
5. At each bracket location, loosely attach one mounting bracket using the included M8 and M10 hardware. *Note: brackets mount to the rocker panel using the same method as the driver side.*

6. Secure the Plastic Bracket Covers (item 19) to the Mounting Brackets using the supplied M6 Hardware (items 11-13). See **Figure 4**.
7. Fasten driver and passenger side step bars to their respective sides using the M8 hardware provided with the step bars. See **Figures 5 & 6**.
8. Align and adjust the step bars as needed and fully tighten all hardware. Torque all M6 fasteners to 5-7 ft-lbs and all M8 fasteners to 15-18 ft-lbs.

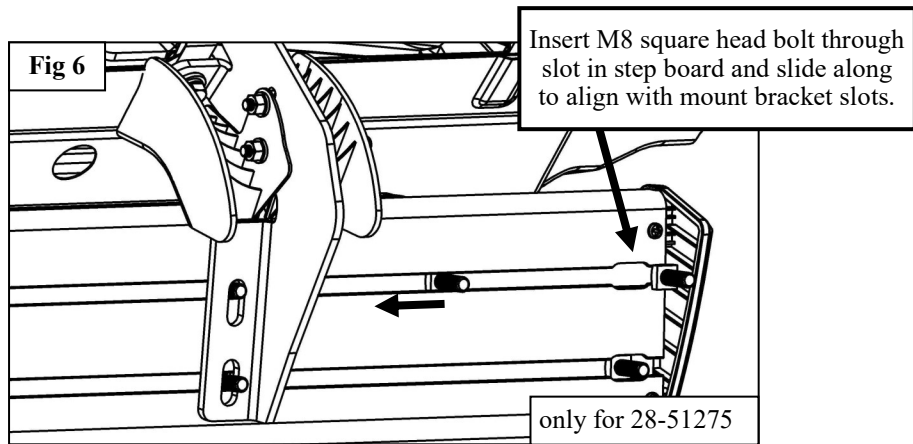
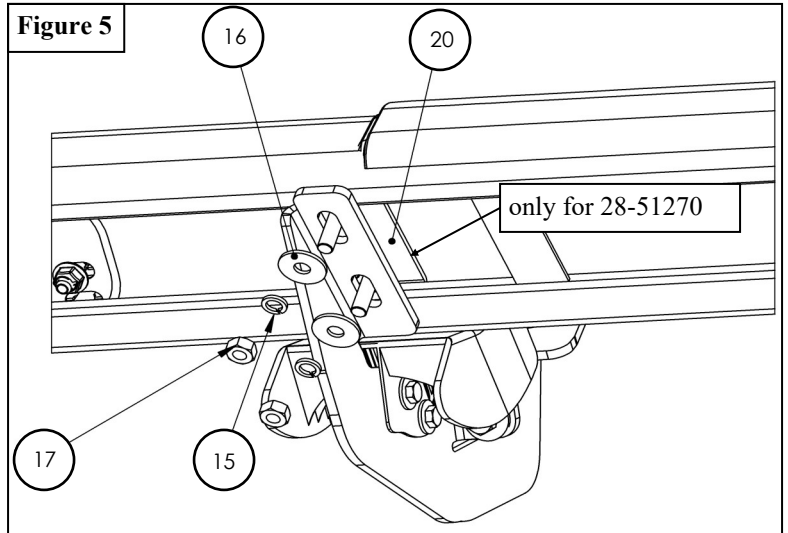
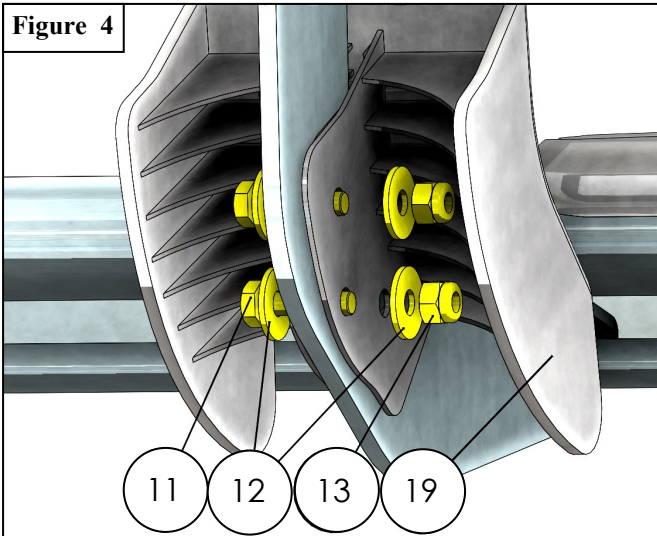

INSTALLATION COMPLETE



CARE INSTRUCTIONS

- REGULAR WAXING IS RECOMMENDED. DO NOT USE ANY TYPE OF POLISH OR WAX THAT MAY CONTAIN ABRASIVES.
- STAINLESS STEEL PRODUCTS CAN BE CLEANED WITH MILD SOAP AND WATER. STAINLESS STEEL POLISH SHOULD BE USED TO POLISH SMALL SCRATCHES.
- GLOSS BLACK FINISHES SHOULD BE CLEANED WITH MILD SOAP AND WATER.

WESTIN