

INSTALLATION INSTRUCTIONS

Grate Steps Running Board



PART NUMBER:

- 27-74725 (75" Running Board)
- 27-74735 (79" Running Board)
- 27-74745 (90" Running Board)
- 27-74755 (86" Running Board)
- 27-74765 (83" Running Board)

CONTENT			
ITEM	QUANTITY	DESCRIPTION	TOOLS NEEDED
1,2	2	RUNNING BOARD ASSEMBLY, DRIVER (1) AND PASSENGER (2)	13MM SOCKET
3	8	ADAPTER BRACKET (6 PREINSTALLED IN RUNNING BOARD ASSEMBLIES)	4MM HEX KEY
4	8	PLATE A (6 PREINSTALLED IN RUNNING BOARD ASSEMBLIES)	RATCHET
5	8	PLATE B	TORQUE WRENCH
6	16	M8 SET SCREW (BLACK ZINC) (12 PREINSTALLED IN RUNNING BOARD ASSEMBLIES)	
7	16	M8 SPLIT LOCK WASHER (YELLOW ZINC)	
8	16	M8 HEX NUT (YELLOW ZINC)	

ANTI-SEIZE LUBRICANT MUST BE USED ON ALL STAINLESS STEEL FASTENERS TO PREVENT THREAD DAMAGE AND GALLING

The driver side Running Board Assembly (item 1) includes (3) preinstalled Adapter Brackets (item 3), (3) preinstalled Plate A (item 4), and (6) preinstalled M8 Set Screws (item 6).
 The passenger side Running Board Assembly (item 2) includes (3) preinstalled Adapter Brackets (item 3), (3) preinstalled Plate A (item 4), and (6) preinstalled M8 Set Screws (item 6).

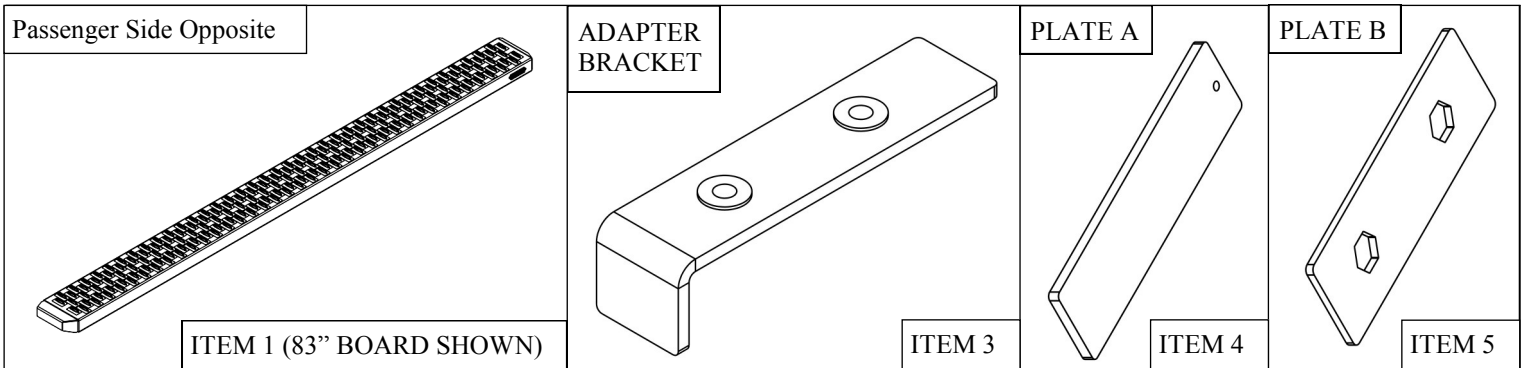

PROCEDURE

1. Remove contents from box, verify if all parts listed are present and free from damage.
 Carefully read and understand all instructions before attempting installation.
Failure to identify damage before installation could lead to a rejection of any claim.



2. Install brackets according the instructions included with the mount kit (**sold separately**).
3. For applications with 8 mounting brackets, insert (1) Adapter Bracket (item 3) and (1) Plate A (item 4) into each Running Board Assembly (items 1 & 2). See **Figures 1 and 2**.
Note: For every Mount Bracket, one Adapter Bracket and one Plate A will be required.

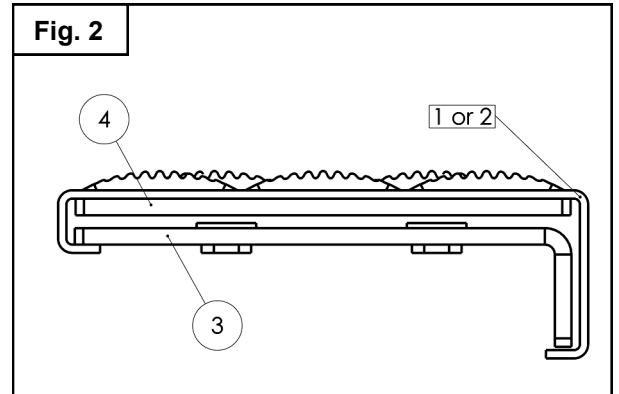
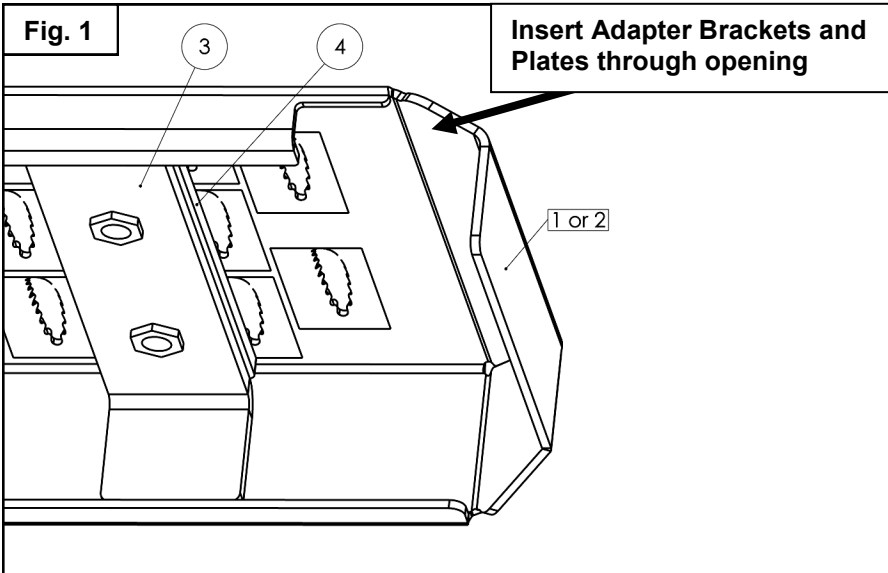

4. For each Adapter Bracket (item 3) installed in **Step 3**, thread two M8 Set Screws (item 6) into each of the weld nuts.
Note: Do not tighten M8 Set Screws at this time.
5. Place the Running Board Assemblies (items 1 & 2) on top of the Mount Brackets.
6. Loosen M8 set screws (item 6) and adjust Adapter Brackets (item 3) and Plate A (item 4) so that the M8 Set Screws align with the Mount Bracket slots. See **Figure 3**.

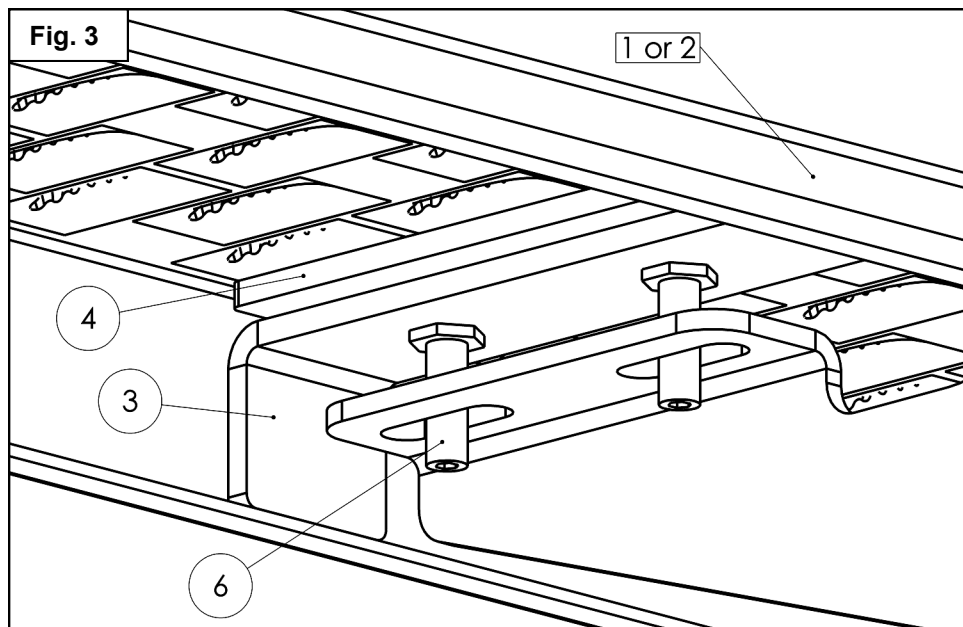

7. Adjust the Running Board Assemblies (item 1 & 2) along the length of the vehicle.
8. For each Adapter Bracket (item 3), lift the Running Board Assembly and place a Plate B (item 5) between the Adapter Bracket and the Mount Bracket. See **Figure 4**.
9. Tighten the M8 Set Screws (item 6) until the Adapter Bracket begins to bend.

Note: Do not overtighten the M8 Set Screws. This may damage the Adapter Brackets. The separation between the Adapter Bracket and Plate B should be no more than 1/16" of an inch.
10. For each Adapter Bracket/Mount Bracket pair, use (2) M8 or 5/16" Flat Washers (included with mount kit), (2) M8 Hex Nuts (item 8), and (2) M8 Split Lock Washers (item 7) to secure the Adapter Brackets (item 3) to the Mount Brackets. See **Figure 4**.
11. Tighten all M8 hardware to 15-18 ft-lbs.

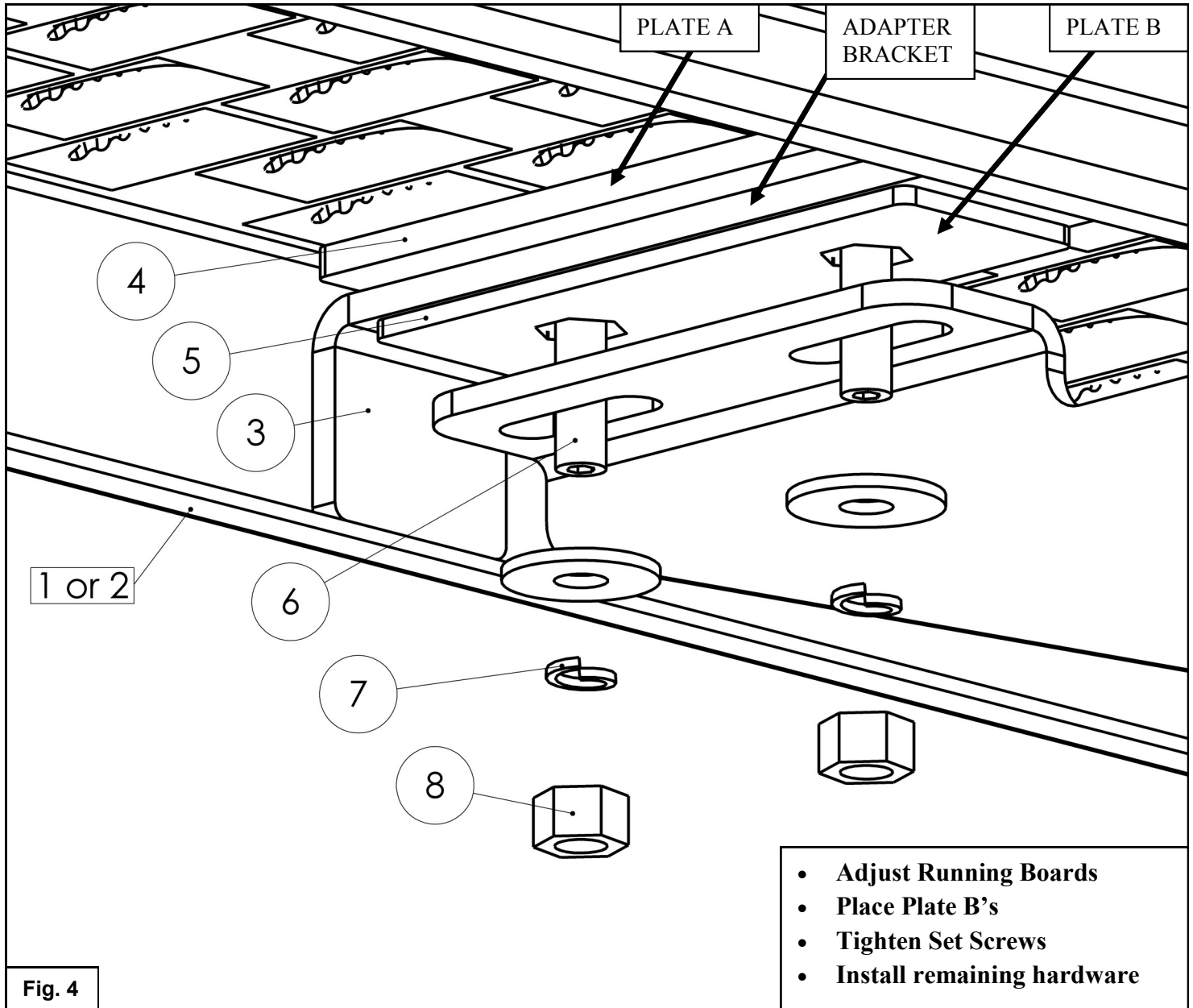

INSTALLATION COMPLETE



CARE INSTRUCTIONS

- REGULAR WAXING IS RECOMMENDED. DO NOT USE ANY TYPE OF POLISH OR WAX THAT MAY CONTAIN ABRASIVES.
- STAINLESS STEEL PRODUCTS CAN BE CLEANED WITH MILD SOAP AND WATER. STAINLESS STEEL POLISH SHOULD BE USED TO POLISH SMALL SCRATCHES.
- GLOSS BLACK FINISHES SHOULD BE CLEANED WITH MILD SOAP AND WATER

WESTIN



WARNING



Failure to follow these instructions could lead to death, personal injury, and / or property damage.

Failure to follow these instructions could lead to death, personal injury, and / or property damage.

FASTENERS:

All Westin supplied fasteners must be utilized and installed in accordance with the installation instructions and apply torque to the specifications as defined. **DOUBLE CHECK ALL FASTENERS BEFORE INITIAL USE, AND PERIODICALLY IN THE FUTURE TO ENSURE PROPER FUNCTION AND SAFETY.**

DRILLING:

Most Westin products do not require drilling for installation. If drilling is defined as required, use caution when drilling a vehicle. **FAILURE TO REVIEW AN AREA TO BE DRILLED MAY RESULT IN PERSONAL INJURY AND/OR INJURY TO OTHERS AS WELL AS VEHICLE DAMAGE.**

EYE PROTECTION:

ALWAYS WEAR SAFETY GLASSES OR GOGGLES DURING THE INSTALLATION PROCESS TO AVOID PERSONAL INJURY.

MAXIMUM TOWING/CARRYING CAPACITY: (if applicable)

The Westin Receiver Hitches will have a visible tow rating label affixed directly on the product. User should never exceed the vehicle manufacturers maximum tow and weight rating regardless of the capacity of the hitch. **FAILURE TO FOLLOW THESE GUIDELINES WILL VOID THE WESTIN WARRANTY AND MAY RESULT IN PERSONAL INJURY AND/OR INJURY TO OTHERS AS WELL AS VEHICLE DAMAGE.**

FOR CALIFORNIA RESIDENTS ONLY-PROP 65 WARNING:

Some products may contain chemicals such as DEHP, which can cause cancer, birth defects or other reproductive harm.

