

INSTALLATION INSTRUCTIONS

STEP BOARD MOUNT KIT

WESTiN®

APPLICATION:

2019 Chevy Silverado/GMC Sierra 1500 Crew Cab & Double Cab (Excl. 2019 Silverado/Sierra LD/1500 Limited)

PART NUMBER:

27-2255

CONTENT			
ITEM	QUANTITY	DESCRIPTION	TOOLS NEEDED
1	6	MOUNTING BRACKET	13MM SOCKET
2	12	M8 HEX HEAD BOLT	RATCHET
3	24	M8 FLAT WASHER	TORQUE WRENCH
4	12	M8 SPLIT LOCK WASHER	
5	12	M8 SQUARE HEAD BOLT	
6	12	M8 NYLOCK NUT	

ANTI-SEIZE LUBRICANT MUST BE USED ON ALL STAINLESS STEEL FASTENERS TO PREVENT THREAD DAMAGE AND GALLING

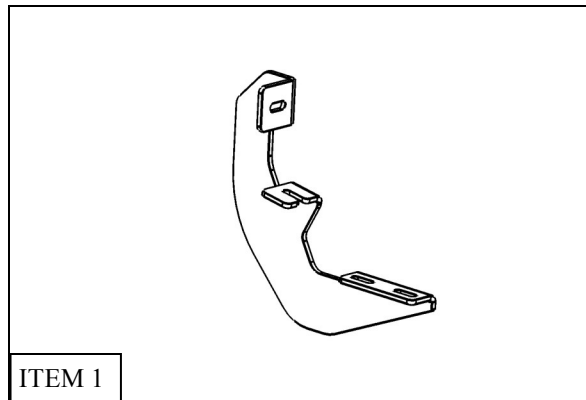

IMPORTANT ALERT: GM uses a very strong thread-locking compound on all body bolts. Use of an air assisted impact ratchet can cause damage to the threads on factory body mount bolts and the internal nut assembly because of this thread locking compound.

We only recommend the use of hand tools to slowly remove and reinstall body mount bolts on all GM vehicles.

PROCEDURE

1. Remove contents from box, verify if all parts listed are present and free from damage.

Carefully read and understand all instructions before attempting installation.

Failure to identify damage before installation could lead to a rejection of any claim.

2. Starting on the driver side, remove any rubber plugs located on the rocker panel at each mounting location. See **Figure 1**.

WESTiN

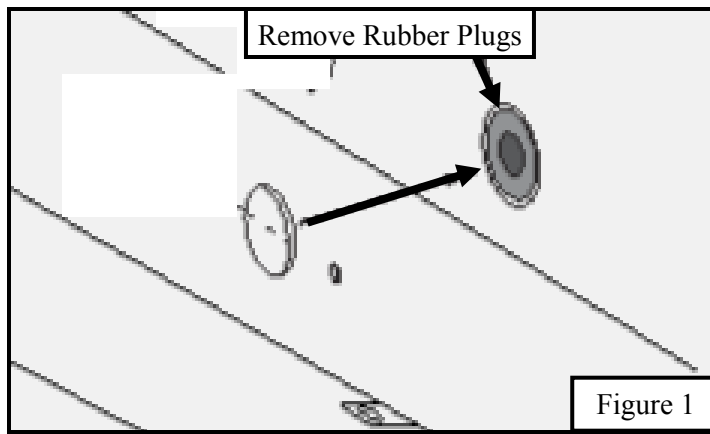

3. Locate (1) Mounting Bracket (Item 1) and loosely secure it to the rocker panel using the provided hardware: (2) M8 hex head bolt, (2) M8 flat washer, and (2) M8 lock washer. See **Figure 2**.
4. Repeat **Step 4** for the remaining bracket mounting location, see **Page 3** for bracket location.

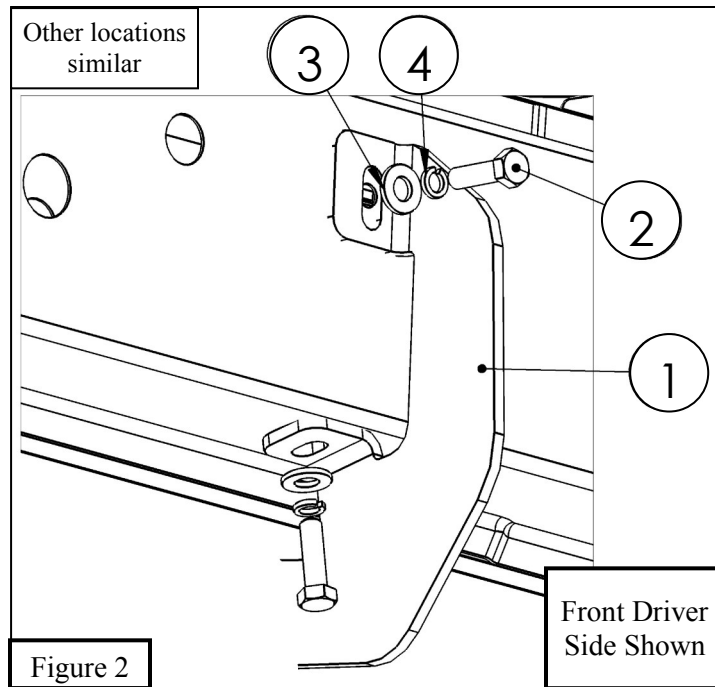

5. Lay the running boards on top of the brackets.
6. Slide the M8 square head bolts (5) through slots on the bottom of the running board (excluding the center slot, three bolts per slot).
7. Loosely install the supplied M8 flat washers (3) and M8 nylon lock nuts (6). See **Figure 3**.
8. Align and adjust the running board as needed and fully tighten all hardware. Torque all M8 fasteners to 15-18 ft-lbs.

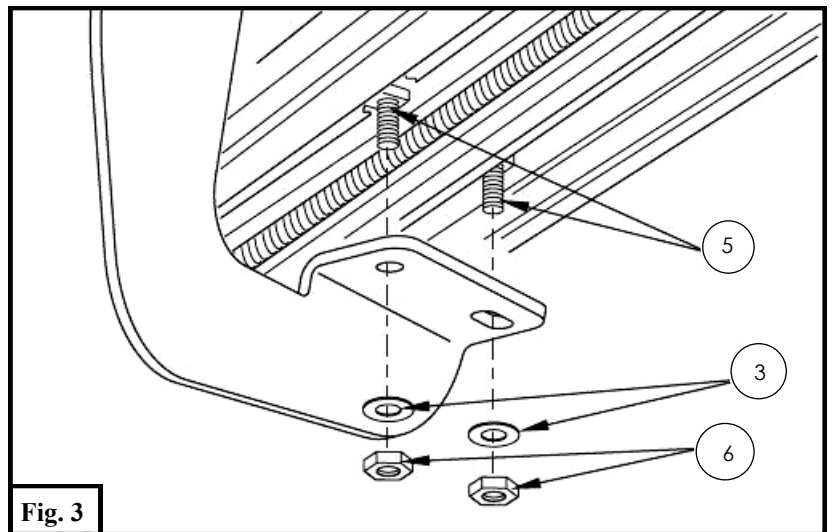

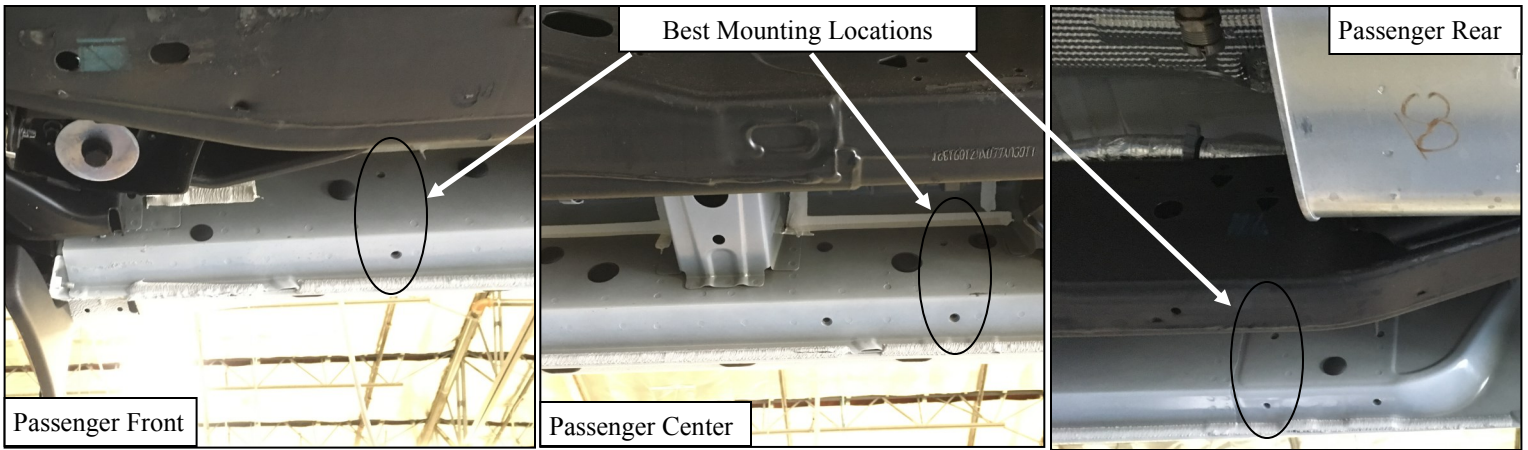

INSTALLATION COMPLETE

Grille Guard and Running Boards Sold Separately





WARNING



Failure to follow these instructions could lead to death, personal injury, and / or property damage.

Failure to follow these instructions could lead to death, personal injury, and / or property damage.

FASTENERS:

All Westin supplied fasteners must be utilized and installed in accordance with the installation instructions and apply torque to the specifications as defined. **DOUBLE CHECK ALL FASTENERS BEFORE INITIAL USE, AND PERIODICALLY IN THE FUTURE TO ENSURE PROPER FUNCTION AND SAFETY.**

DRILLING:

Most Westin products do not require drilling for installation. If drilling is defined as required, use caution when drilling a vehicle. **FAILURE TO REVIEW AN AREA TO BE DRILLED MAY RESULT IN PERSONAL INJURY AND/OR INJURY TO OTHERS AS WELL AS VEHICLE DAMAGE.**

EYE PROTECTION:

ALWAYS WEAR SAFETY GLASSES OR GOGGLES DURING THE INSTALLATION PROCESS TO AVOID PERSONAL INJURY.

MAXIMUM TOWING/CARRYING CAPACITY: (if applicable)

The Westin Receiver Hitches will have a visible tow rating label affixed directly on the product. User should never exceed the vehicle manufacturers maximum tow and weight rating regardless of the capacity of the hitch. **FAILURE TO FOLLOW THESE GUIDELINES WILL VOID THE WESTIN WARRANTY AND MAY RESULT IN PERSONAL INJURY AND/OR INJURY TO OTHERS AS WELL AS VEHICLE DAMAGE.**



Learn more about running boards and step bars we have.