

INSTALLATION INSTRUCTIONS

PRO TRAXX 6 OVAL STEP BAR



APPLICATION:

2019 Chevrolet Silverado/GMC Sierra 1500 Crew Cab & Double Cab (Excl. 2019 Silverado LD/Sierra 1500 Limited)

PART NUMBER:

21-64130, 21-64135 (Crew Cab)

21-64120, 21-64125 (Double Cab)

| CONTENT | | | |
|---------|----------|-------------------------------------|---------------|
| ITEM | QUANTITY | DESCRIPTION | TOOLS NEEDED |
| 1 | 1 | DRIVER STEP BAR ASSEMBLY | 10MM SOCKET |
| 2 | 1 | PASSENGER STEP BAR ASSEMBLY | 10MM WRENCH |
| 3 | 3 | DRIVER MOUNT BRACKET | 13MM SOCKET |
| 4 | 3 | PASSENGER MOUNT BRACKET | 13MM WRENCH |
| 5 | 6 | BRACKET COVER | ALLEN WRENCH |
| 6 | 12 | M8 HEX HEAD BOLT (YELLOW ZINC) | RATCHET |
| 7 | 12 | M8 SPLIT LOCK WASHER (YELLOW ZINC) | TORQUE WRENCH |
| 8 | 12 | M8 FLAT WASHER (YELLOW ZINC) | |
| 9 | 12 | M6 HEX HEAD CAP SCREW (YELLOW ZINC) | |
| 10 | 24 | M6 FLAT WASHER (YELLOW ZINC) | |
| 11 | 12 | M6 NYLOCK NUT (YELLOW ZINC) | |
| 12 | 12 | M8 BUTTON HEAD BOLT (BLACK ZINC) | |
| 13 | 12 | M8 FLAT WASHER (BLACK ZINC) | |
| 14 | 12 | M8 TOOTHED WASHER (BLACK ZINC) | |

ANTI-SEIZE LUBRICANT MUST BE USED ON ALL STAINLESS STEEL FASTENERS TO PREVENT THREAD DAMAGE AND GALLING

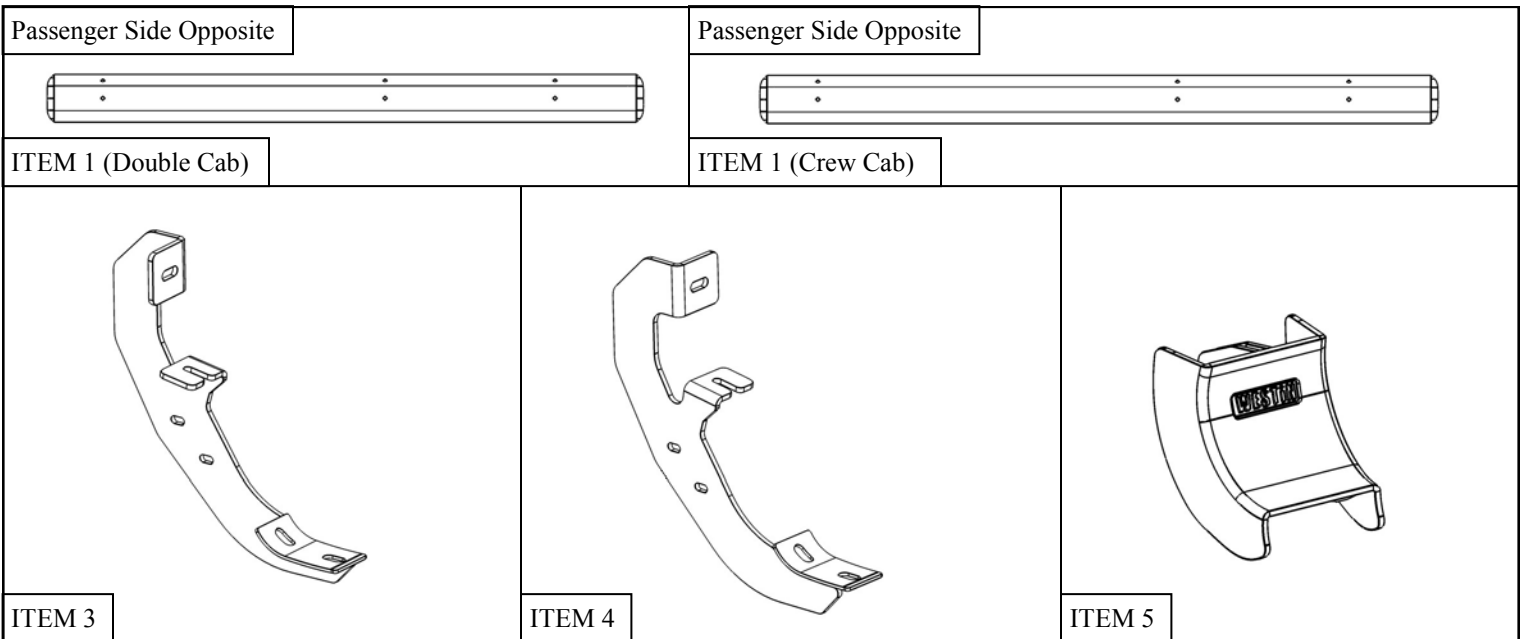

PROCEDURE

1. Remove contents from box, verify if all parts listed are present and free from damage.
Carefully read and understand all instructions before attempting installation.
Failure to identify damage before installation could lead to a rejection of any claim.

2. Starting on the driver side, remove the rubber plugs located on the rocker panel at each mounting location. See **Figure 1**.
3. **For models with threaded holes:** At each bracket mounting location on the rocker panel there should be a welded factory nut.



4. Secure the Plastic Bracket Covers (item 5) to the Mounting Brackets using the supplied M6 Hardware. See **Figure 2**.

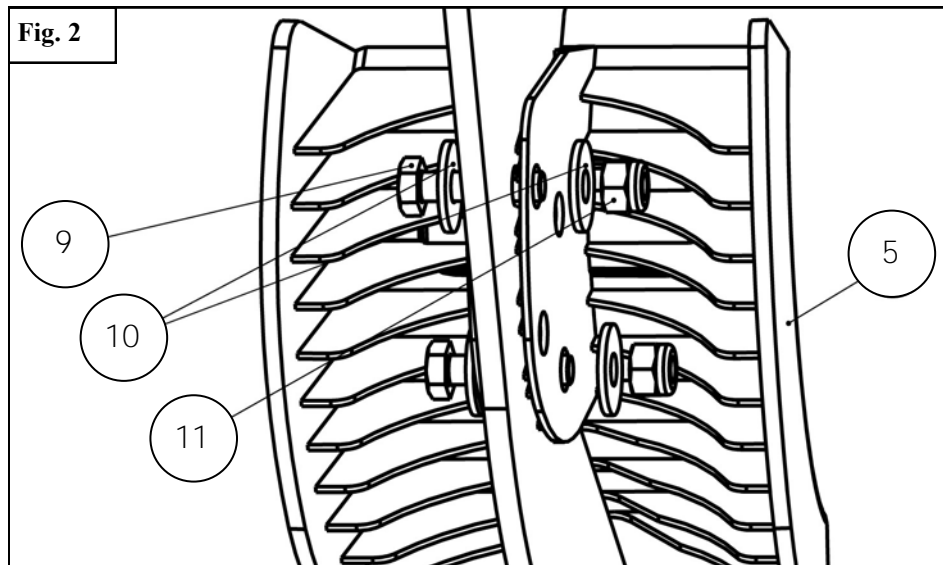

5. Locate (1) Mounting Bracket (Items 3,4) and loosely secure it to the rocker panel using the provided hardware: (2) M8 hex head bolt, (2) M8 flat washer, and (2) M8 lock washer. See **Figures 3, 4 and 5**.
6. Repeat **Step 5** for all remaining bracket mounting locations.

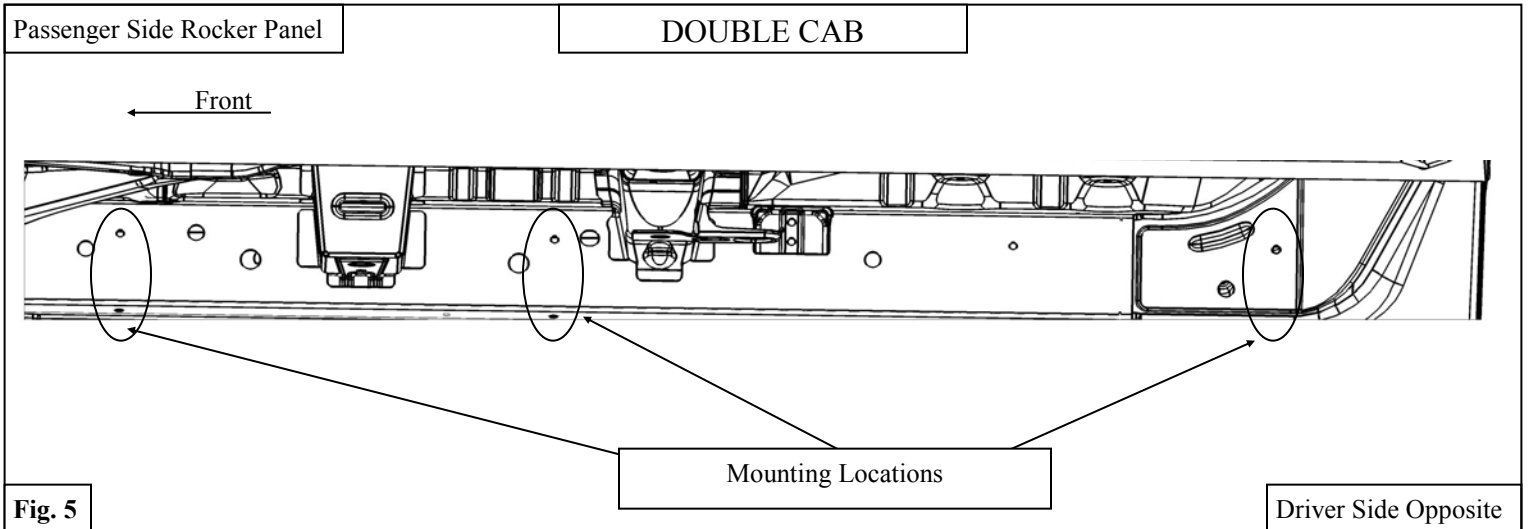
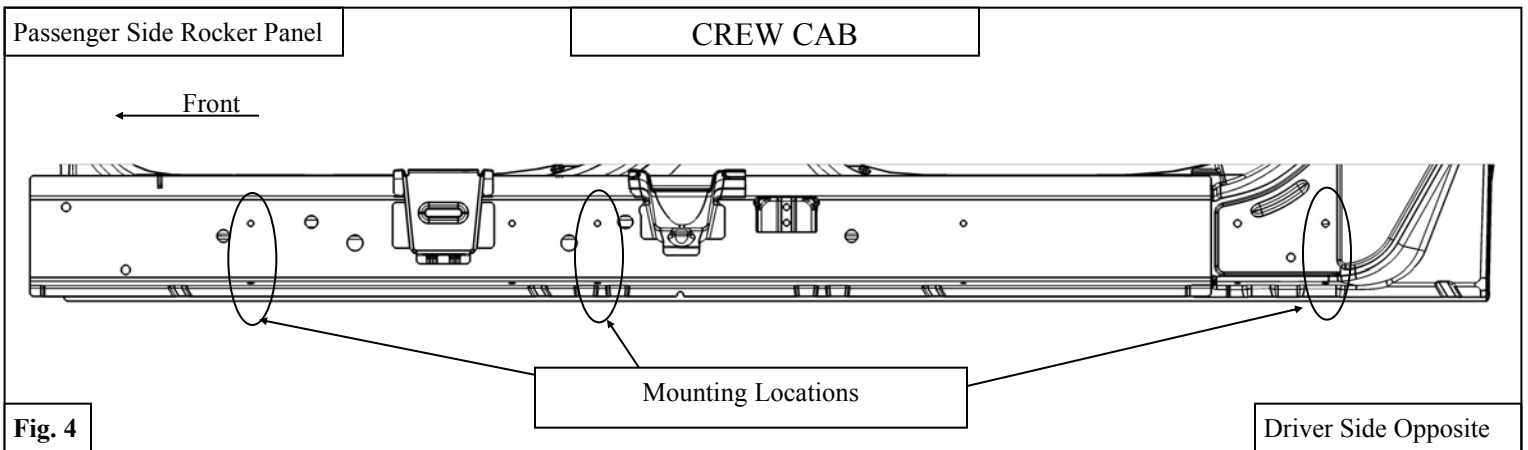
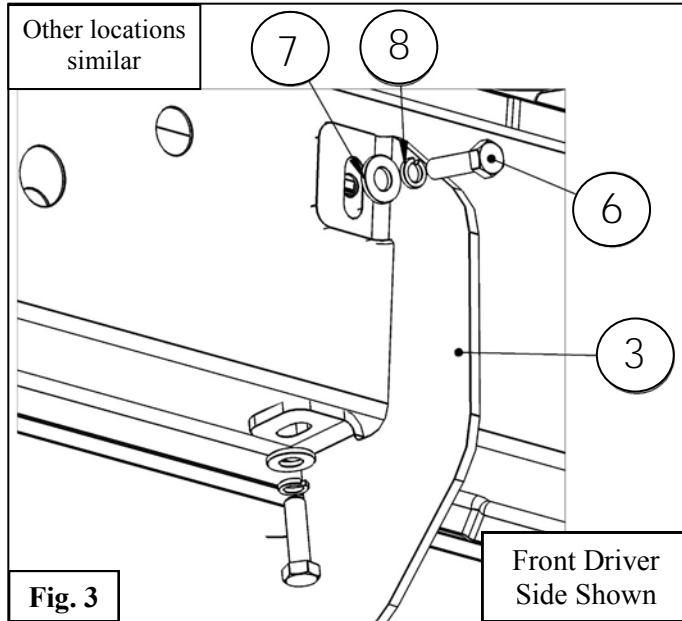

7. Fasten step bars respectively to either side using the M8 hardware provided with the step bars. See **Figure 6**.
8. Align and adjust the step bars as needed and fully tighten all hardware. Torque all M6 fasteners to 5-7 ft-lbs and all M8 fasteners to 15-18 ft-lbs.

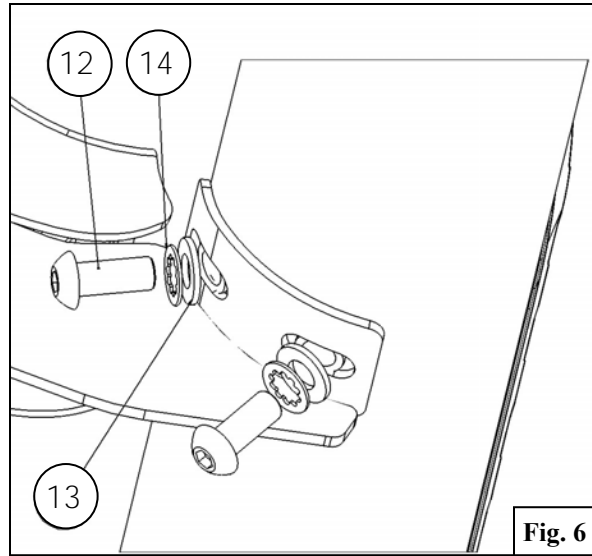

Fig. 6



CARE INSTRUCTIONS

- REGULAR WAXING IS RECOMMENDED. DO NOT USE ANY TYPE OF POLISH OR WAX THAT MAY CONTAIN ABRASIVES.
- STAINLESS STEEL PRODUCTS CAN BE CLEANED WITH MILD SOAP AND WATER. STAINLESS STEEL POLISH SHOULD BE USED TO POLISH SMALL SCRATCHES.
- GLOSS BLACK FINISHES SHOULD BE CLEANED WITH MILD SOAP AND WATER



WARNING



Failure to follow these instructions could lead to death, personal injury, and / or property damage.

Failure to follow these instructions could lead to death, personal injury, and / or property damage.

FASTENERS:

All Westin supplied fasteners must be utilized and installed in accordance with the installation instructions and apply torque to the specifications as defined. **DOUBLE CHECK ALL FASTENERS BEFORE INITIAL USE, AND PERIODICALLY IN THE FUTURE TO ENSURE PROPER FUNCTION AND SAFETY.**

DRILLING:

Most Westin products do not require drilling for installation. If drilling is defined as required, use caution when drilling a vehicle. **FAILURE TO REVIEW AN AREA TO BE DRILLED MAY RESULT IN PERSONAL INJURY AND/OR INJURY TO OTHERS AS WELL AS VEHICLE DAMAGE.**

EYE PROTECTION:

ALWAYS WEAR SAFETY GLASSES OR GOGGLES DURING THE INSTALLATION PROCESS TO AVOID PERSONAL INJURY.

MAXIMUM TOWING/CARRYING CAPACITY: (if applicable)

The Westin Receiver Hitches will have a visible tow rating label affixed directly on the product. User should never exceed the vehicle manufacturers maximum tow and weight rating regardless of the capacity of the hitch. **FAILURE TO FOLLOW THESE GUIDELINES WILL VOID THE WESTIN WARRANTY AND MAY RESULT IN PERSONAL INJURY AND/OR INJURY TO OTHERS AS WELL AS VEHICLE DAMAGE.**



Learn more about running boards and step bars we have.