



INSTALLATION INSTRUCTIONS

PROTRAXX 4 & 5 OVAL STEP BAR

APPLICATION:

2020 Jeep Gladiator

PART NUMBER:

21-24165, 21-24160, 21-54165, 21-54160

CONTENT			
ITEM	QUANTITY	DESCRIPTION	TOOLS NEEDED
1	2	STEP BAR ASSEMBLY, DRIVER AND PASSENGER	RATCHET
2	1	DRIVER FRONT MOUNTING BRACKET	TORQUE WRENCH
3	1	PASSENGER FRONT MOUNTING BRACKET	10MM SOCKET
4	1	DRIVER FRONT SUPPORT BRACKET	13MM SOCKET
5	1	PASSENGER FRONT SUPPORT BRACKET	13MM WRENCH
6	1	DRIVER CENTER MOUNTING BRACKET	ALLEN WRENCH
7	1	PASSENGER CENTER MOUNTING BRACKET	SOCKET EXT.
8	1	DRIVER CENTER SUPPORT BRACKET	
9	1	PASSENGER CENTER SUPPORT BRACKET	
10	1	DRIVER REAR MOUNTING BRACKET	
11	1	PASSENGER REAR MOUNTING BRACKET	
12	1	DRIVER REAR SUPPORT BRACKET	
13	1	PASSENGER REAR SUPPORT BRACKET	
14	6	M8 EXTRUDED U NUT	
15	12	M8 HEX HEAD BOLT (YELLOW ZINC)	
16	24	M8 SPLIT LOCK WASHER (YELLOW ZINC)	
17	18	M8 HEX NUT (YELLOW ZINC)	
18	30	M8 FLAT WASHER (YELLOW ZINC)	
19	12	M8 FLAT WASHER (BLACK ZINC)	
20	12	M8 BUTTON HEAD BOLT (BLACK ZINC)	
21	12	M10 BUTTON HEAD BOLT (BLACK ZINC)	
22	12	M10 FLAT WASHER (BLACK ZINC)	
23	12	M10 INTERNAL TOOTHED LOCK WASHER (BLACK ZINC)	

ANTI-SEIZE LUBRICANT MUST BE USED ON ALL STAINLESS STEEL FASTENERS TO PREVENT THREAD DAMAGE AND GALLING



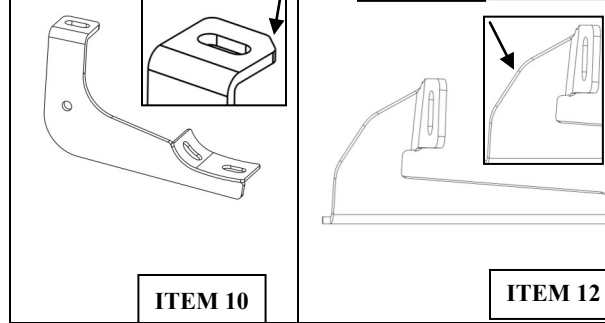
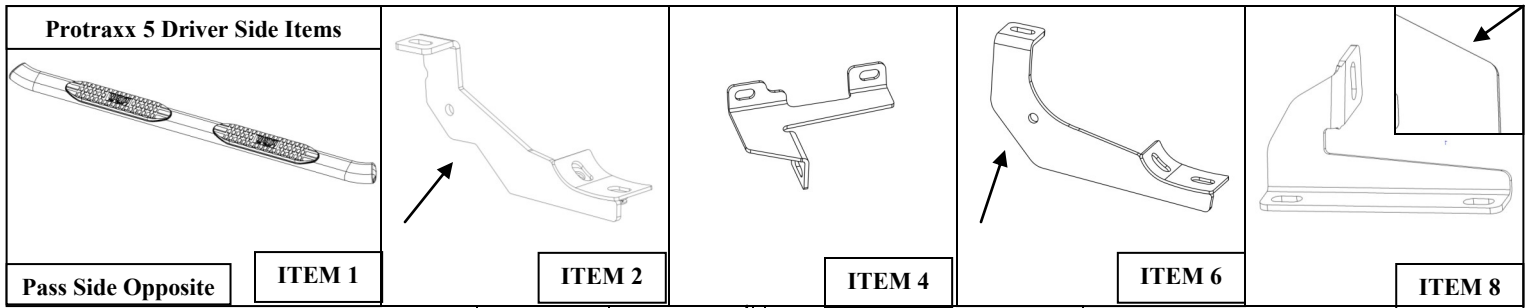
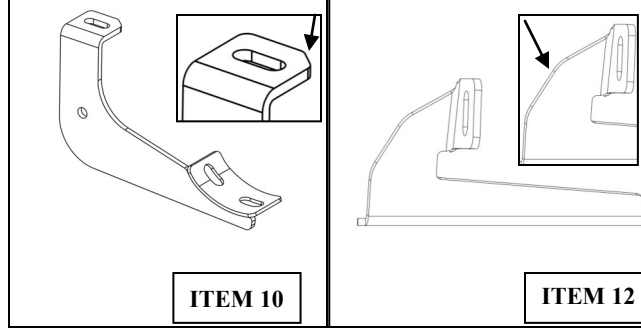
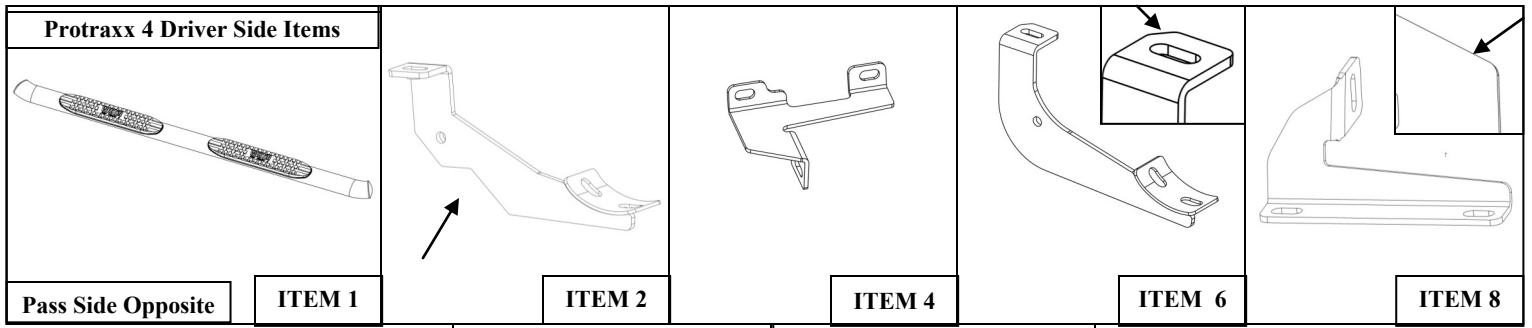

PROCEDURE

1. Remove contents from box, verify if all parts listed are present and free from damage.
Carefully read and understand all instructions before attempting installation.
Failure to identify damage before installation could lead to a rejection of any claim.

2. Starting at the front mount location, locate (1) Front Mount Bracket and (1) Front Support Bracket. Loosely secure brackets, using: (4) M8 hex head cap screw, (1) M8 extruded u-nut, (4) M8 split lock washer, (3) M8 hex nut, (5) M8 flat washer, **See Figure 1.** **Note:** M8 extruded u-nut is only used if a threaded hole is not present (circled on **Figure 1**).
3. For the rear mounting location, locate (1) Rear Mount Bracket and (1) Rear Support Bracket. Loosely secure brackets, using: (4) M8 hex head cap screw, (1) M8 extruded u-nut, (4) M8 split lock washer, (3) M8 hex nut, (5) M8 flat washer. **Note:** M8 extruded u-nut is only used if a threaded hole is not present. **See Figure 2.**

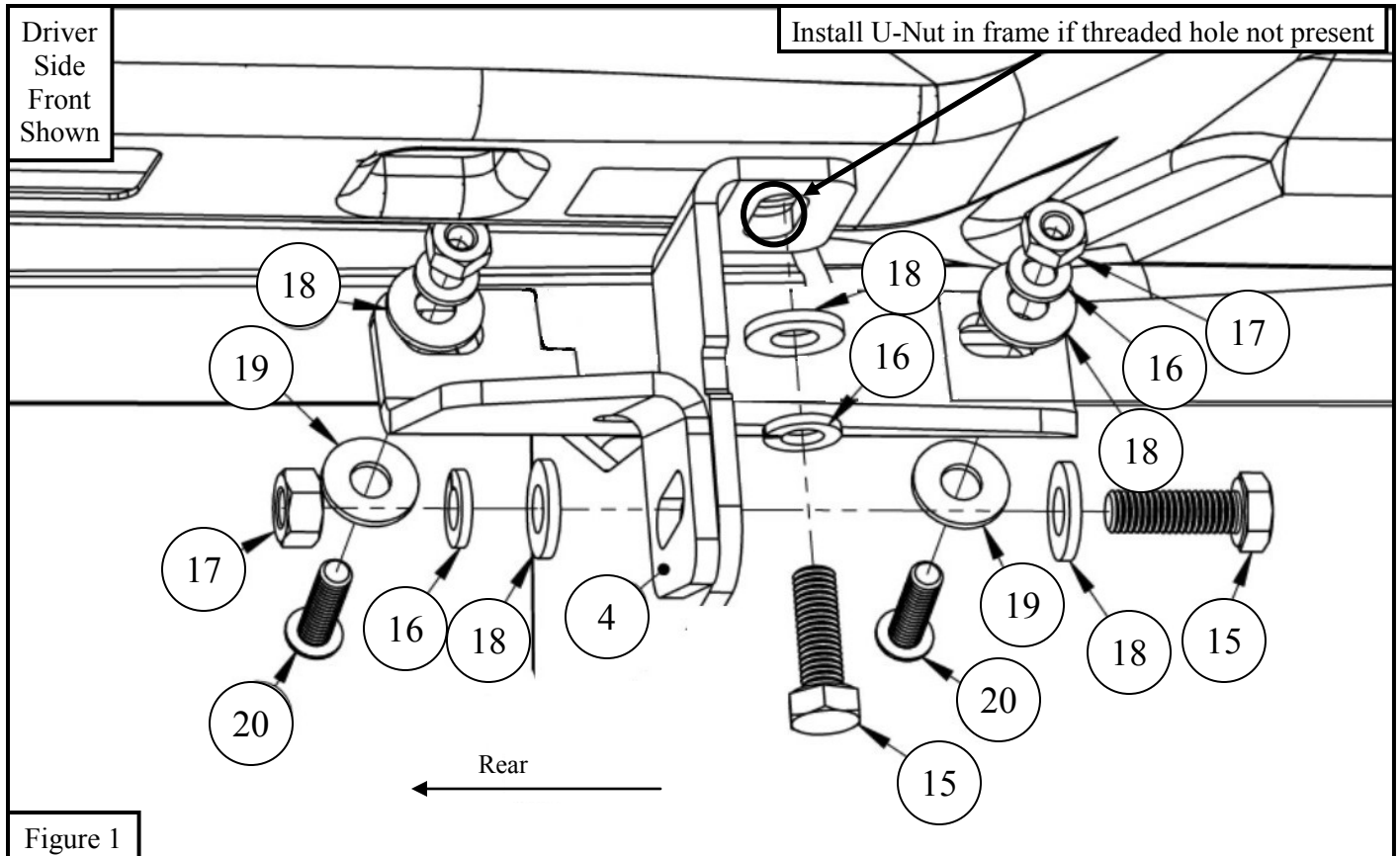

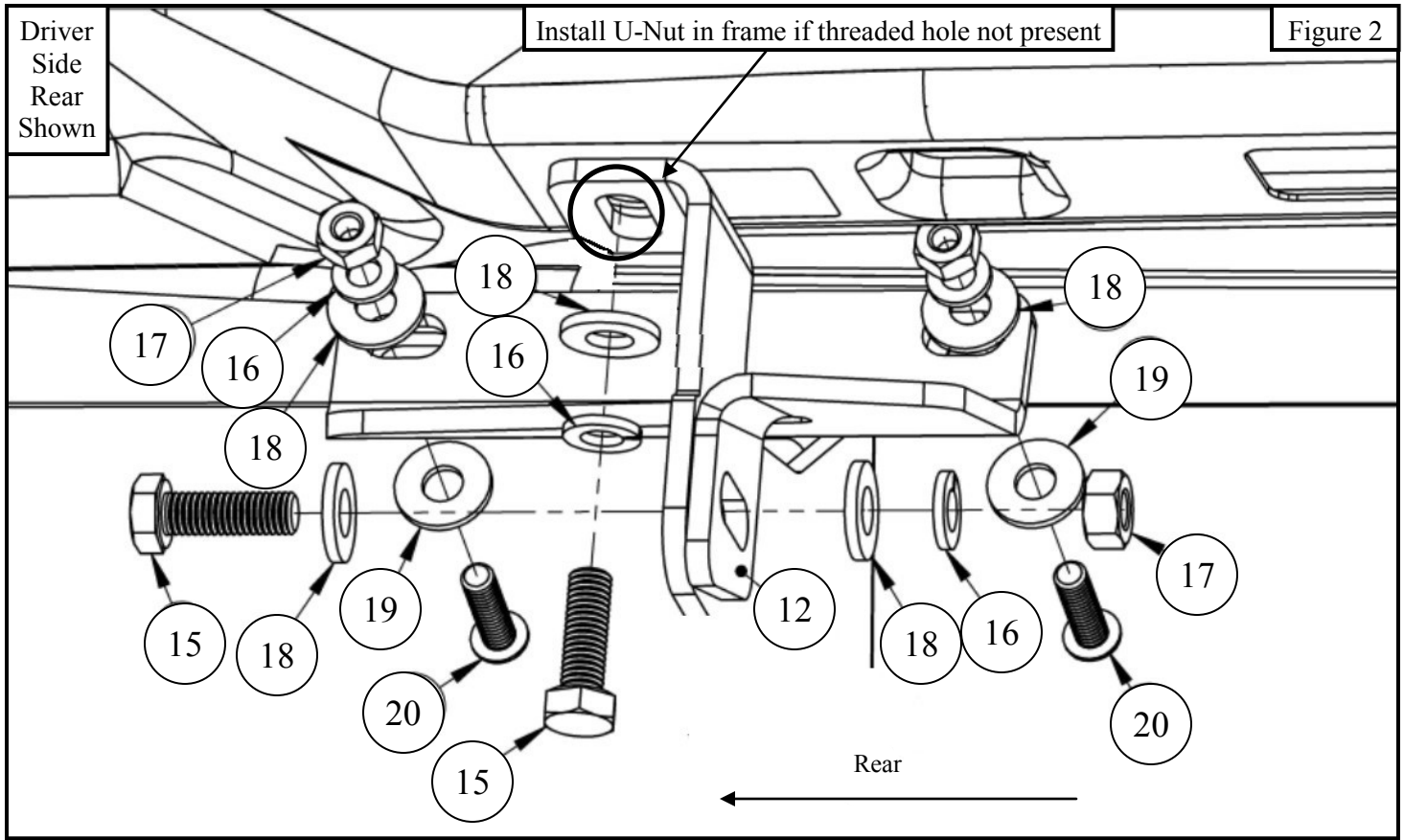

4. Mount the center brackets in the same orientation as the rear brackets.
5. Repeat **Steps 2-4** on the passenger side.
6. Locate (1) Step Bar Assembly and loosely secure it onto the previously installed brackets using the provided M10 hardware. **See Figure 3.** Install opposite side after.
7. See **Figure 4** for visual bracket orientation.

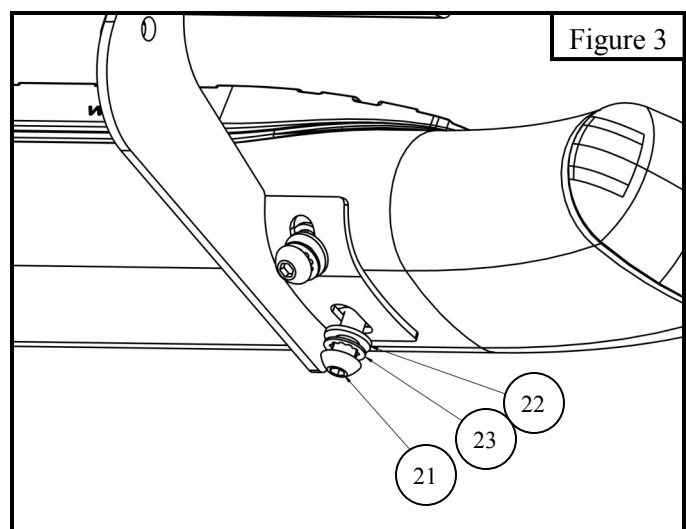

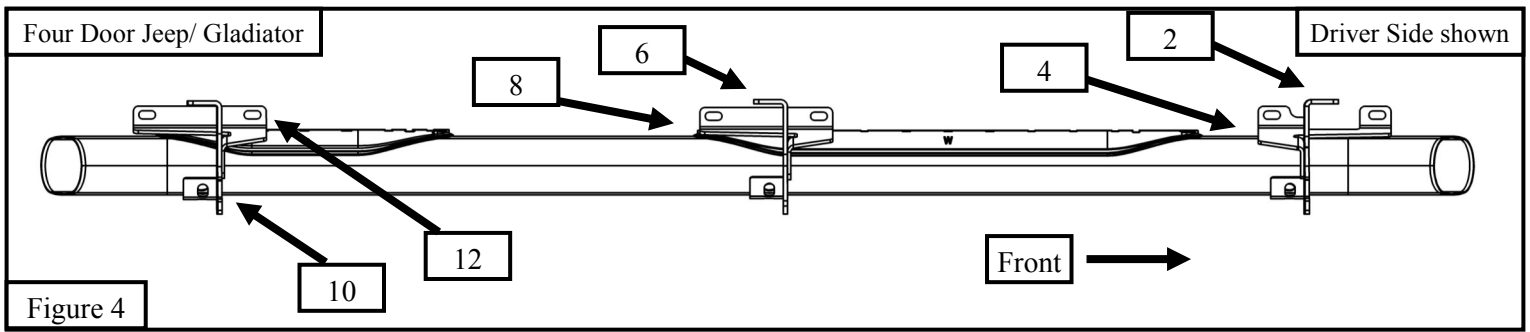

8. Align step bar and brackets to desired positioning then torque and tighten all: M8 hardware to 16 ft-lbs and M10 to 32 ft-lbs.



Care Instructions

- REGULAR WAXING IS RECOMMENDED. DO NOT USE ANY TYPE OF POLISH OR WAX THAT MAY CONTAIN ABRASIVES.
- STAINLESS STEEL PRODUCTS CAN BE CLEANED WITH MILD SOAP AND WATER. STAINLESS STEEL POLISH SHOULD BE USED TO POLISH SMALL SCRATCHES.
- GLOSS BLACK FINISHES SHOULD BE CLEANED WITH MILD SOAP AND WATER.

WESTiN