



INSTALLATION INSTRUCTIONS

PROTRAXX 4 & PROTRAXX 5

APPLICATION:

2018 Jeep Wrangler 4Dr JL

PART NUMBER:

21-24060, 21-24065, 21-54060, 21-54065

CONTENT			
ITEM	QUANTITY	DESCRIPTION	TOOLS NEEDED
1	2	STEP BAR ASSEMBLY	RATCHET
2	2	CENTER MOUNT BRACKET, DRIVER AND PASSENGER	TORQUE WRENCH
3	4	CENTER SUPPORT BRACKET, DRIVER AND PASSENGER	10MM SOCKET
4	2	FRONT MOUNT BRACKET, DRIVER AND PASSENGER	13MM SOCKET
5	2	FRONT SUPPORT BRACKET, DRIVER AND PASSENGER	13MM WRENCH
6	2	REAR MOUNT BRACKET, DRIVER AND PASSENGER	SOCKET EXT.
7	12	M10 INTERNAL TOOTHED LOCK WASHER (S/S BLACK ZINC)	ALLEN WRENCH
8	6	M8 EXTRUDED U-NUT (YELLOW ZINC)	
9	12	M8 HEX HEAD CAP SCREW (YELLOW ZINC)	
10	24	M8 SPLIT LOCK WASHER (YELLOW ZINC)	
11	18	M8 HEX NUT (YELLOW ZINC)	
12	30	M8 FLAT WASHER (YELLOW ZINC)	
13	12	M10 BUTTON HEAD CAP SCREW (S/S BLACK ZINC)	
14	12	M8 BUTTON HEAD CAP SCREW (S/S BLACK ZINC)	
15	12	M8 FLAT WASHER (S/S BLACK ZINC)	
16	12	M10 FLAT WASHER (S/S BLACK ZINC)	

ANTI-SEIZE LUBRICANT MUST BE USED ON ALL STAINLESS STEEL FASTENERS TO PREVENT THREAD DAMAGE AND GALLING

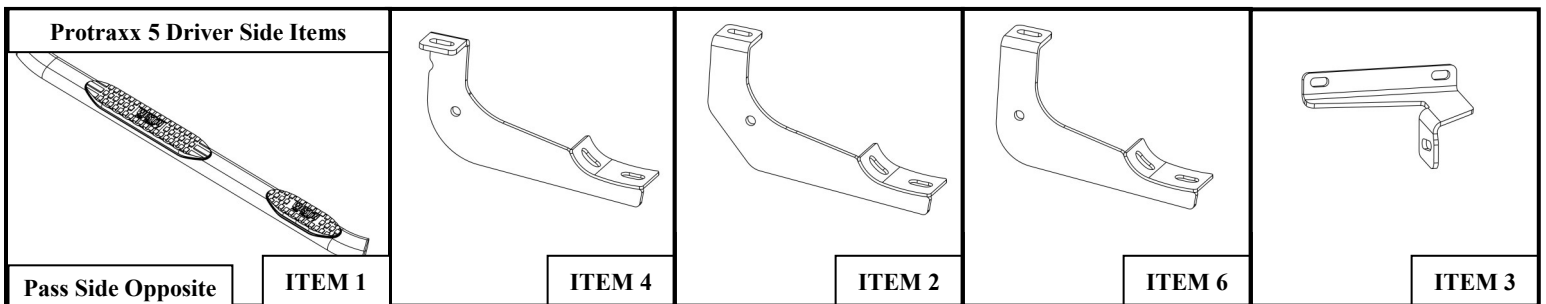
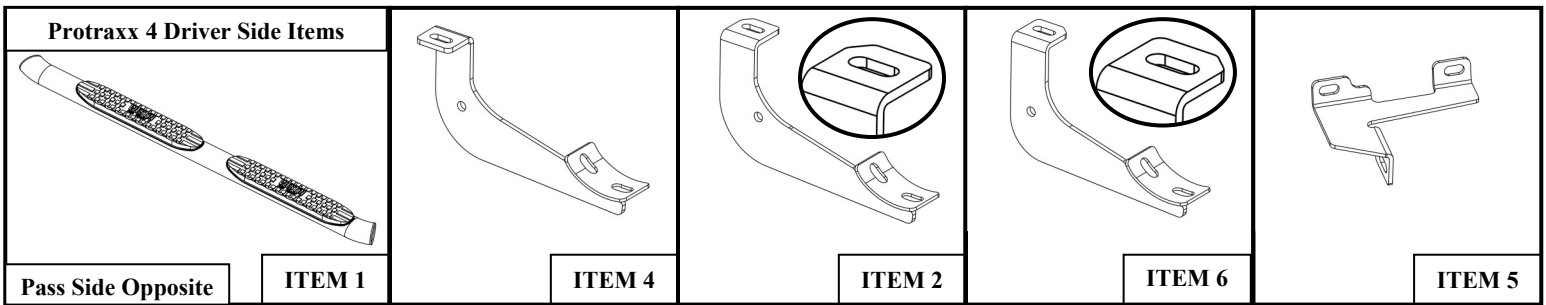

PROCEDURE

1. Remove contents from box, verify if all parts listed are present and free from damage.

Carefully read and understand all instructions before attempting installation.

Failure to identify damage before installation could lead to a rejection of any claim.

2. Starting at the front mount location, locate (1) Front Mount Bracket (Item 4) and (1) Front Support Bracket (Item 5). Loosely secure brackets, using: (4) M8 hex head cap screw, (1) M8 extruded u-nut, (4) M8 split lock washer, (3) M8 hex nut, (5) M8 flat washer, **See Figure 1.** **Note:** M8 extruded u-nut is only used if a threaded hole is not present (circled on **Figure 1**).
3. For the rear mounting location, locate (1) Rear Mount Bracket (Item 6) and (1) Center Support Bracket (Item 3). Loosely secure brackets, using: (4) M8 hex head cap screw, (1) M8 extruded u-nut, (4) M8 split lock washer, (3) M8 hex nut, (5) M8 flat washer. **Note:** M8 extruded u-nut is only used if a threaded hole is not present. **See Figure 2.**

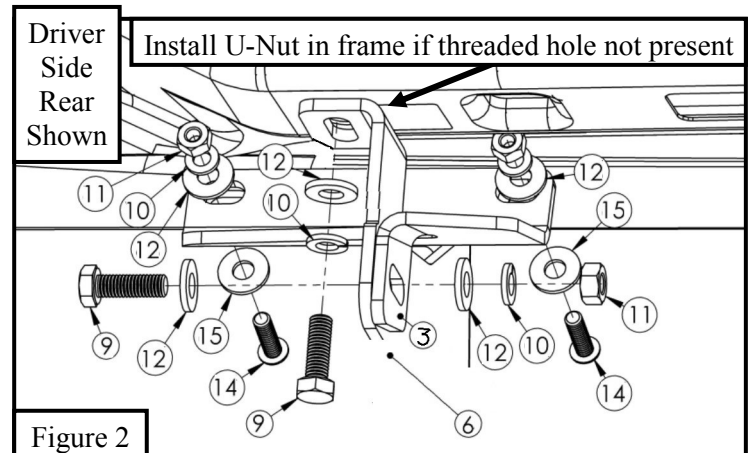
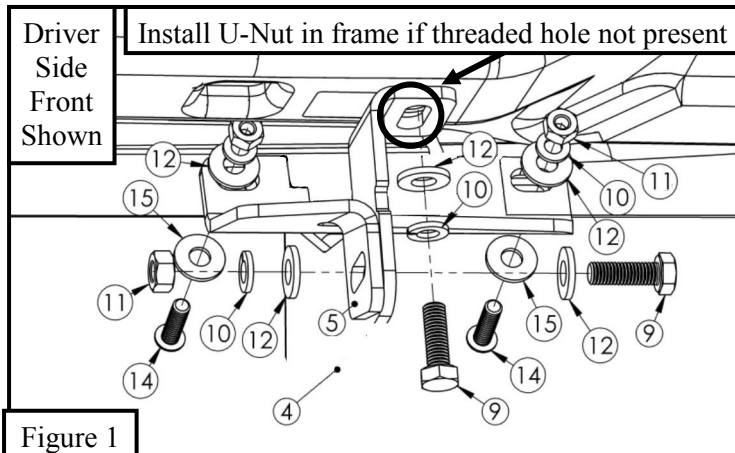

4. Center mount location similar to rear.
5. Locate (1) Step Bar Assembly and loosely secure it onto the previously installed brackets using the provided M10 hardware. **See Figure 3.**
6. See **Figure 4** for visual bracket orientation.
7. Align step bar and brackets to desired positioning then torque and tighten all: M8 hardware to 16 ft-lbs and M10 to 32 ft-lbs.

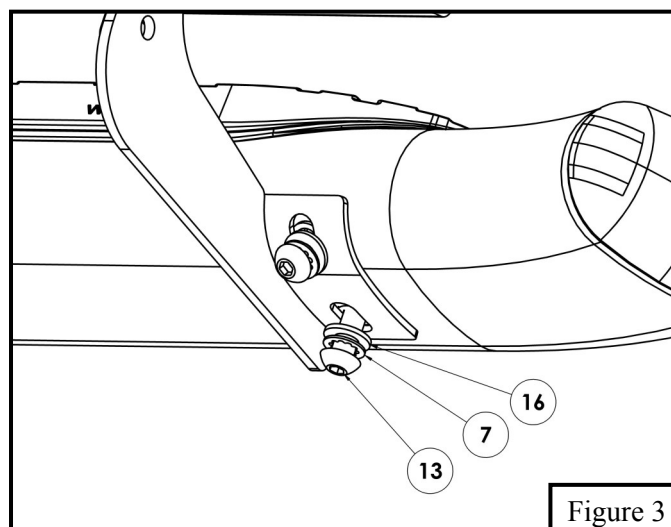

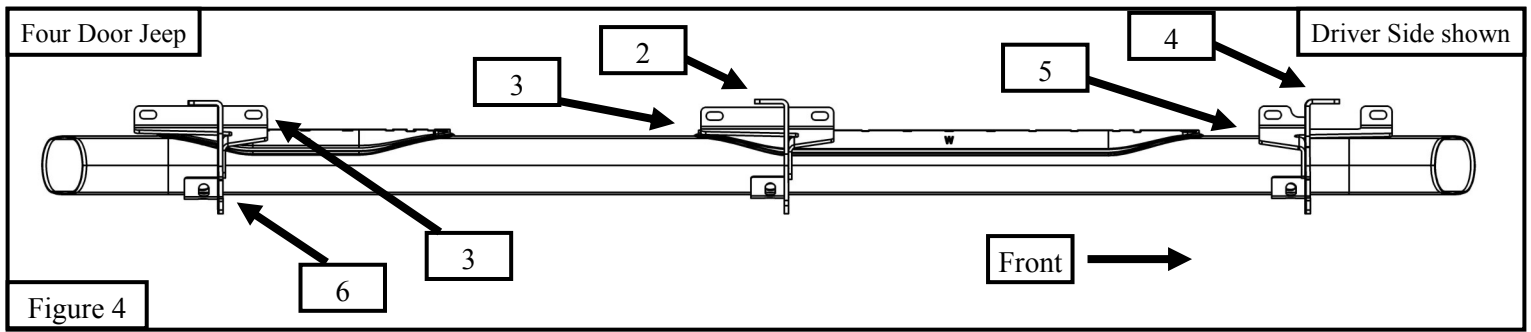

Care Instructions

- REGULAR WAXING IS RECOMMENDED. DO NOT USE ANY TYPE OF POLISH OR WAX THAT MAY CONTAIN ABRASIVES.
- STAINLESS STEEL PRODUCTS CAN BE CLEANED WITH MILD SOAP AND WATER. STAINLESS STEEL POLISH SHOULD BE USED TO POLISH SMALL SCRATCHES.
- GLOSS BLACK FINISHES SHOULD BE CLEANED WITH MILD SOAP AND WATER.

Westin

SIGNATURE OF QUALITY

AUTOMOTIVE PRODUCTS, INC.



WARNING



Failure to follow these instructions could lead to death, personal injury, and / or property damage.

FASTENERS:

All Westin supplied fasteners must be utilized and installed in accordance with the installation instructions and apply torque to the specifications as defined. **DOUBLE CHECK ALL FASTENERS BEFORE INITIAL USE, AND PERIODICALLY IN THE FUTURE TO ENSURE PROPER FUNCTION AND SAFETY.**

DRILLING:

Most Westin products do not require drilling for installation. If drilling is defined as required, use caution when drilling a vehicle. **FAILURE TO REVIEW AN AREA TO BE DRILLED MAY RESULT IN PERSONAL INJURY AND/OR INJURY TO OTHERS AS WELL AS VEHICLE DAMAGE.**

EYE PROTECTION:

ALWAYS WEAR SAFETY GLASSES OR GOGGLES DURING THE INSTALLATION PROCESS TO AVOID PERSONAL INJURY.

MAXIMUM TOWING/CARRYING CAPACITY:

The Westin Receiver Hitches will have a visible tow rating label affixed directly on the product. User should never exceed the vehicle manufacturers maximum tow and weight rating regardless of the capacity of the hitch. **FAILURE TO FOLLOW THESE GUIDELINES WILL VOID THE WESTIN WARRANTY AND MAY RESULT IN PERSONAL INJURY AND/OR INJURY TO OTHERS AS WELL AS VEHICLE DAMAGE.**

Westin
SIGNATURE OF QUALITY

Š^æ} Ā [!^Áæ[~ óáā Ā ~ æâ• Áæ āĀ ā āĀ^~^&ç !•Ā ^Áæ^Ē