

INSTALLATION INSTRUCTIONS

PRO TRAXX 5 NERF STEP BARS



APPLICATION:

2020 Chevrolet/ GMC Silverado/Sierra 2500/3500 Crew Cab
(8'bed, 6.5' bed), Double Cab (8' Bed)

PART NUMBER:

21-534750, 21-534755, 21-534760, 21-534765, 21-534770, 21-534775

CONTENT			
ITEM	QUANTITY	DESCRIPTION	TOOLS NEEDED
1	1	DRIVER STEP BAR	10MM SOCKET
2	1	PASSENGER STEP BAR	10MM WRENCH
3	3	DRIVER MOUNTING BRACKET	16MM SOCKET
4	3	PASSENGER MOUNTING BRACKET	16MM WRENCH
5	1	DRIVER TOP ISOLATOR MOUNT	RATCHET
6	1	PASSENGER TOP ISOLATOR MOUNT	TORQUE WRENCH
7	1	DRIVER BOTTOM ISOLATOR BRACKET	
8	1	PASSENGER BOTTOM ISOLATOR BRACKET	
9	2	ISOLATOR KIT	
10	8	BRACKET COVER	
11	12	M8 HEX HEAD BOLT (YELLOW ZINC)	
12	12	M8 SPLIT LOCK WASHER (YELLOW ZINC)	
13	12	M8 FLAT WASHER (YELLOW ZINC)	
14	16	M6 HEX HEAD BOLT (YELLOW ZINC)	
15	32	M6 FLAT WASHER (YELLOW ZINC)	
16	16	M6 NYLOCK NUT (YELLOW ZINC)	
17	2	M12 HEX HEAD BOLT (YELLOW ZINC)	
18	2	M12 SPLIT LOCK WASHER (YELLOW ZINC)	
19	16	M10 BUTTON HEAD BOLT (BLACK ZINC)	
20	16	M10 TOOTH LOCK WASHER (BLACK ZINC)	
21	16	M10 FLAT WASHER (BLACK ZINC)	

ANTI-SEIZE LUBRICANT MUST BE USED ON ALL STAINLESS STEEL FASTENERS TO PREVENT THREAD DAMAGE AND GALLING





ITEM 1 (Pro Traxx 5)

8 ft bed shown, 6.5 ft similar

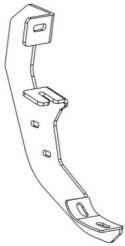

ITEM 3

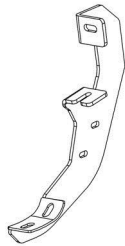

ITEM 4

ITEM 5

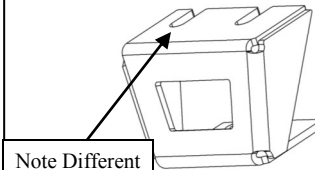

Note Different Offset

ITEM 6

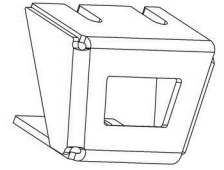

ITEM

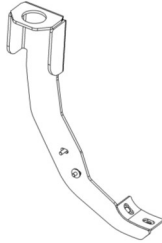

ITEM 8

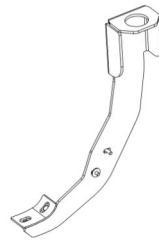

ITEM 9



PROCEDURE

1. Remove contents from box, verify if all parts listed are present and free from damage. Carefully read and understand all instructions before attempting installation.
Failure to identify damage before installation could lead to a rejection of any claim.
2. Starting on the driver side, remove the rubber plugs located on the rocker panel at each mounting location. See **Figure 1**.
3. **For models with threaded holes:** At each bracket mounting location on the rocker panel there should be a welded factory nut.



Fig. 1

4. Locate (1) Driver Mount Bracket. Loosely secure Driver Mount Bracket to the rocker panel using (2) M8 hex head bolt long, (2) M8 flat washer, and (2) M8 lock washer. See **Figure 3**. Refer to **Page 4** bracket orientation figures.

5. Loosely preinstall the Bracket Covers to the Mounting Brackets using the included M6 Hardware. See **Figure 2**.
6. Partially install the M8 Hardware in the bottom of the rocker panel and then slide the Mounting Brackets into place and install the remaining M8 Hardware. See **Figures 3 & 4**.

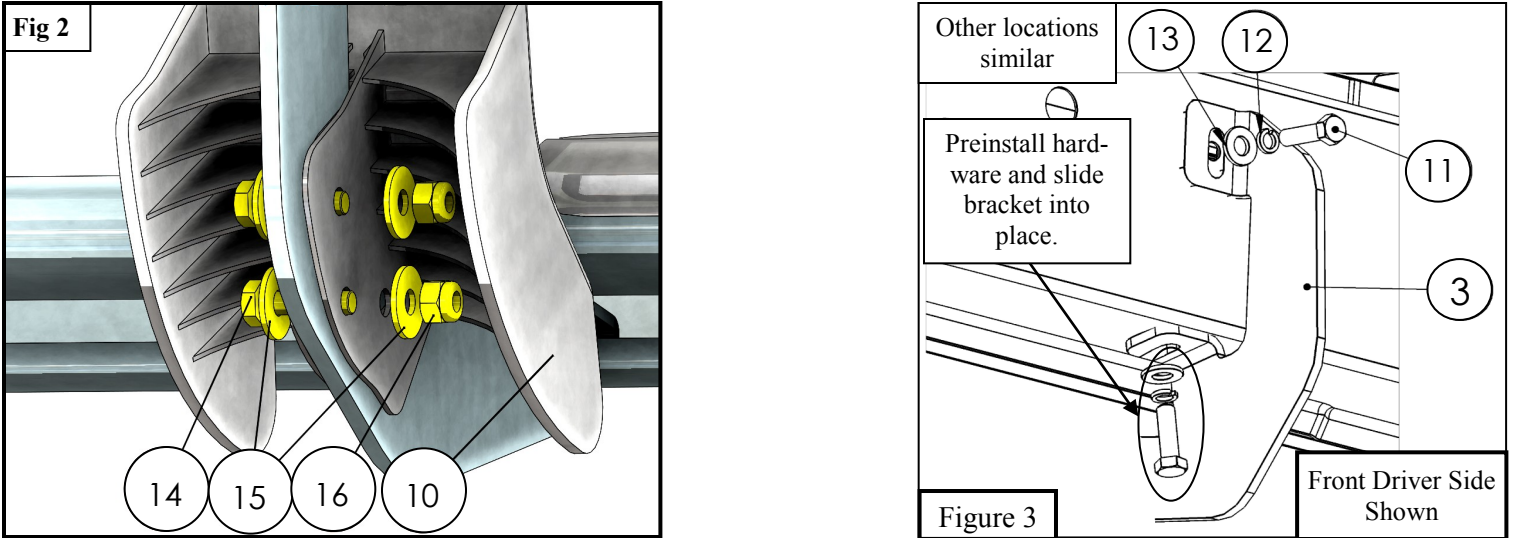
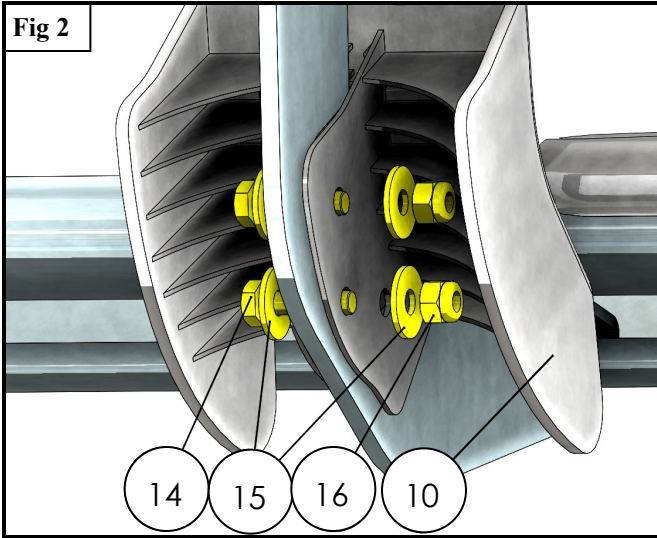

7. Attach the Bottom Isolator Bracket to the Top Isolator Bracket using the Isolator Kit hardware. See **Figure 4**.
8. Under the front of the bed, there is two factory bolts as shown in **Figure 5**. Remove these bolts.
9. Using Preexisting factory bolts, mount the isolator bracket assembly in between the bed and factory bed bracket. See **Figures 4-6**

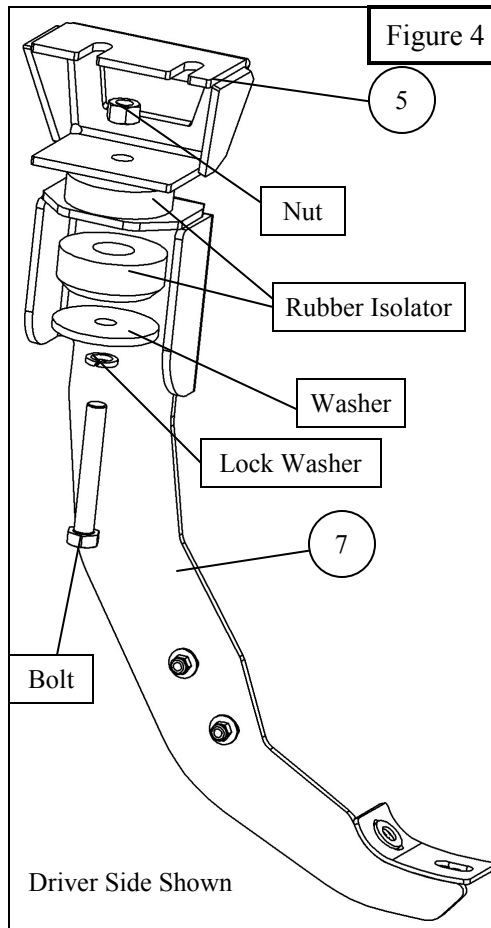

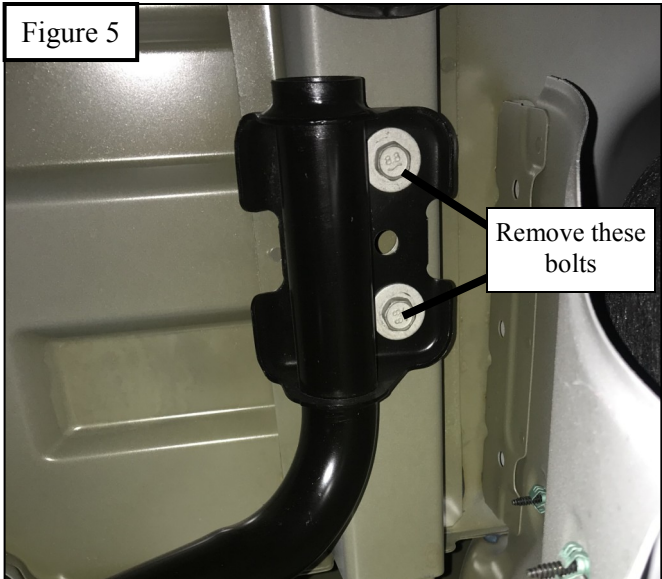

Shorter bed shown, wheel wells will be back further on 8 ft. bed.



10. Fasten step bars respectively to either side using the included M10 hardware. See **Figure 7**.
11. Align and adjust the step bars as needed and fully tighten all hardware. Torque all M6 fasteners to 5-7 ft-lbs, all M8 fasteners to 15-18 ft-lbs, and all M10 fasteners to 30-35 ft-lbs.

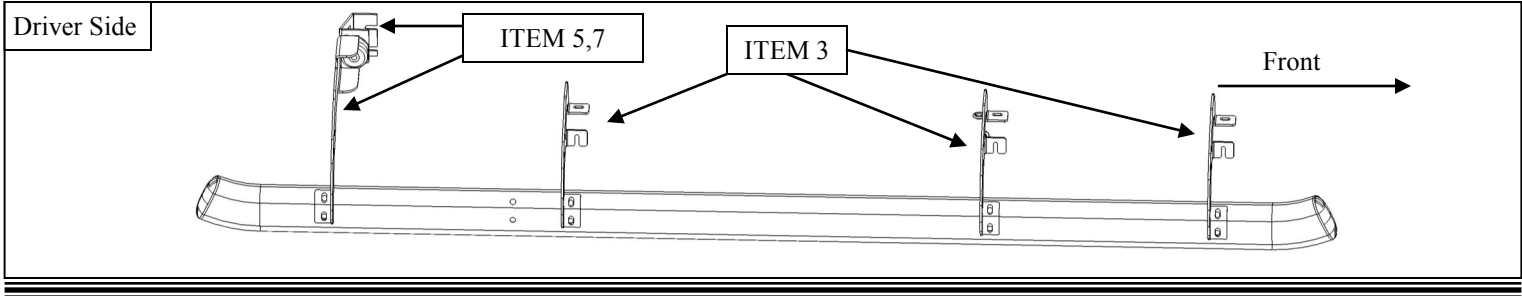
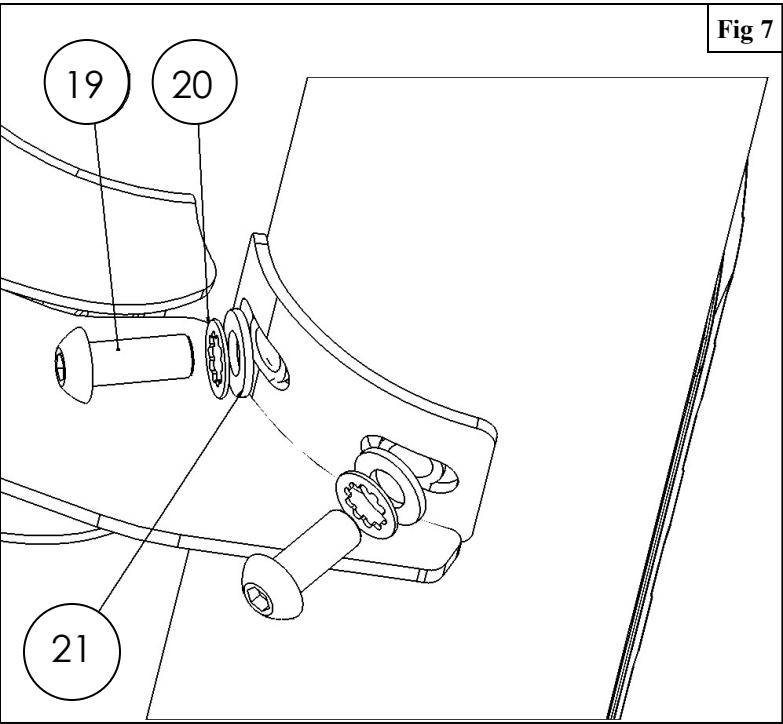

INSTALLATION COMPLETE



6.5' Bed Shown

CARE INSTRUCTIONS

- REGULAR WAXING IS RECOMMENDED. DO NOT USE ANY TYPE OF POLISH OR WAX THAT MAY CONTAIN ABRASIVES.
- STAINLESS STEEL PRODUCTS CAN BE CLEANED WITH MILD SOAP AND WATER. STAINLESS STEEL POLISH SHOULD BE USED TO POLISH SMALL SCRATCHES.
- GLOSS BLACK FINISHES SHOULD BE CLEANED WITH MILD SOAP AND WATER

WESTIN