



INSTALLATION INSTRUCTIONS

PRO TRAXX 5 OVAL WHEEL TO WHEEL NERF STEP BARS

APPLICATION:

Ram 1500 Quad Cab & Crew Cab 2019 (6.5 ft. Bed) (Excl. 2019 Ram 1500 Classic)

PART NUMBER:

21-534730, 21-534735, 21-534720, 21-534725

CONTENT			
ITEM	QUANTITY	DESCRIPTION	TOOLS NEEDED
1	2	STEP BAR ASSEMBLY (1 DRIVER, 1 PASSENGER)	16MM SOCKET
2	2	MOUNTING BRACKET A	16MM WRENCH
3	1	MOUNTING BRACKET B	13MM SOCKET
4	3	MOUNTING BRACKET D	13MM WRENCH
5	2	TOP ISOLATOR BRACKET (1 DRIVER, 1 PASSENGER)	10MM SOCKET
6	2	TOP ISOLATOR BRACE (1 DRIVER, 1 PASSENGER)	10MM WRENCH
7	2	BOTTOM ISOLATOR BRACKET (1 DRIVER, 1 PASSENGER)	15MM SOCKET
8	6	MOUNTING BRACKET BASE	1/2" EXTENSION
9	4	ISOLATOR KIT	RATCHET
10	6	PLASTIC BRACKET COVER	TORQUE WRENCH
11	24	M8 HEX NUT (YELLOW ZINC)	IMPACT GUN
12	24	M8 THICK FLAT WASHER (YELLOW ZINC)	BREAKER BAR
13	24	M8 SPLIT LOCK WASHER (YELLOW ZINC)	
14	2	M10 FLANGED HEX BOLT (YELLOW ZINC)	
15	2	M10 FLAT WASHER (YELLOW ZINC)	
16	2	M10 HEX NUT (YELLOW ZINC)	
17	6	M8 SQUARE NECK BOLT (BLACK ZINC)	
18	16	M10 BUTTON HEAD SCREW (BLACK ZINC)	
19	16	M10 TOOTHED LOCK WASHER (BLACK ZINC)	
20	16	M10 FLAT WASHER (BLACK ZINC)	
21	12	M6 HEX HEAD CAP SCREW (YELLOW ZINC)	
22	24	M6 FLAT WASHER (YELLOW ZINC)	
23	12	M6 NYLOCK NUT (YELLOW ZINC)	
24	1	HEX KEY TOOL	
25	18	M8 PLASTIC RETAINER SQUARES	

ANTI-SEIZE LUBRICANT MUST BE USED ON ALL STAINLESS STEEL FASTENERS TO PREVENT THREAD DAMAGE AND GALLING



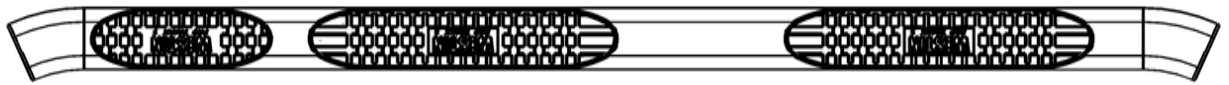

ITEM 1

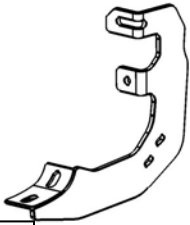

ITEM 2

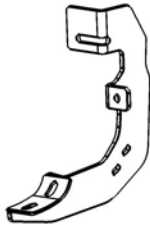

ITEM 3

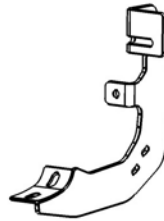

ITEM 4

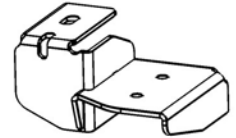

ITEM 5

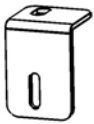

ITEM 6

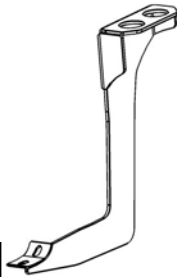

ITEM 7

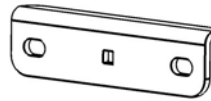

ITEM 8

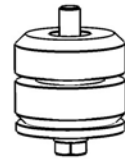

ITEM 9



ITEM 10

**DRIVER SIDE ITEMS SHOWN
PASSENGER SIDE OPPOSITE
WHEN APPLICABLE**

PROCEDURE

1. Remove contents from box, verify if all parts listed are present and free from damage.
Carefully read and understand all instructions before attempting installation.
Failure to identify damage before installation could lead to a rejection of any claim.

2. Preassemble the Mounting Brackets and Mounting Bracket Bases (2,3,4,8). Do not tighten hardware at this time. See **Figure 1**.

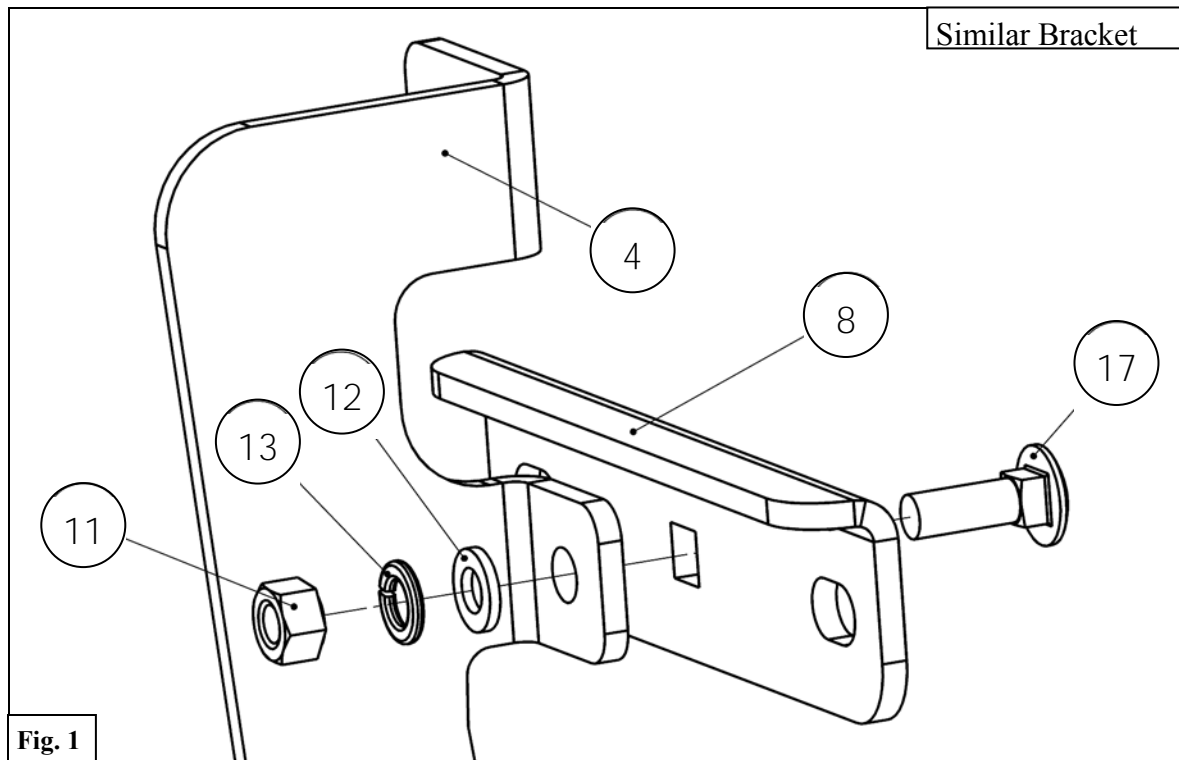

3. Starting on the passenger side of the vehicle, locate the 3 mounting locations on the rocker panel.
- Note A:** The rear mounting location is shown in **Figure 2**. Other mounting locations are similar.
- Note B:** The lower two studs on the rocker panel have a thick coat of paint on them. When installing the M8 hex nuts, apply extra pressure to start. If necessary, back M8 hex nuts off the studs to clear build up.
- See **Figure 2**.

Rear Mounting Location Shown
Other Mounting Locations are Similar

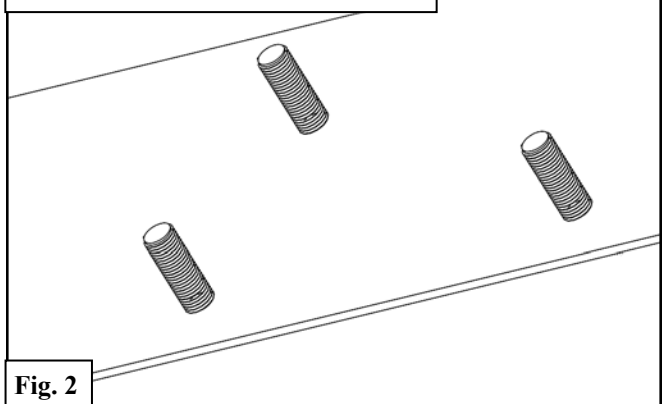

4. At the rear mounting location, loosely install Mounting Bracket D (4) with preassembled Mounting Bracket Base (8) using the supplied M8 hardware. See **Figures 3 & 4**.

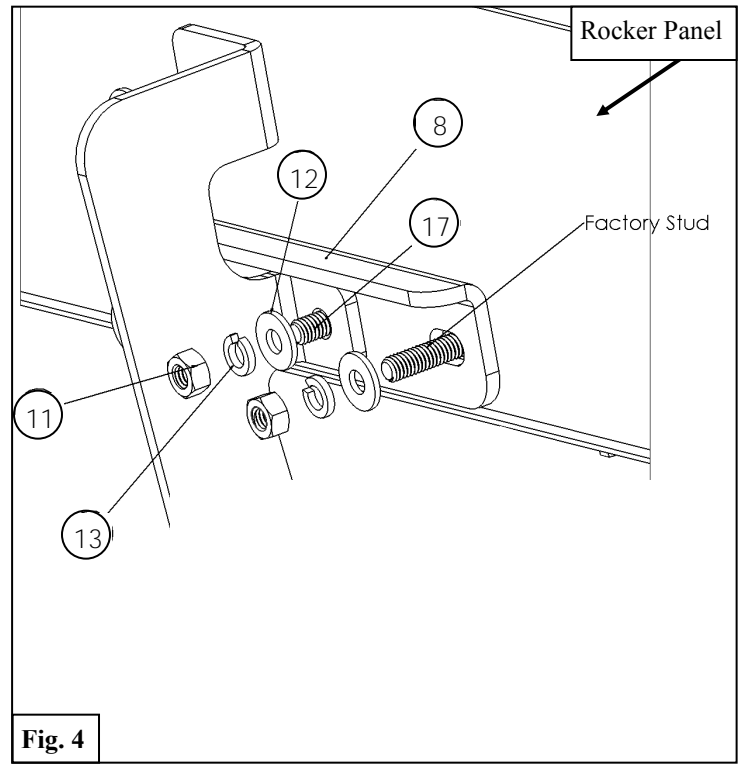
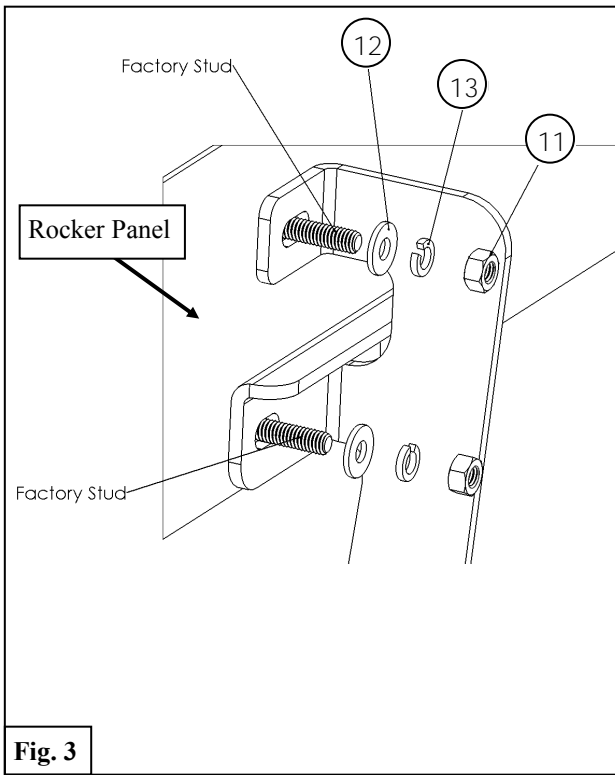

5. At the center mounting location, loosely install Mounting Bracket A (2) with preassembled Mounting Bracket Base (8) using the supplied M8 hardware. See **Figures 5 & 6**.

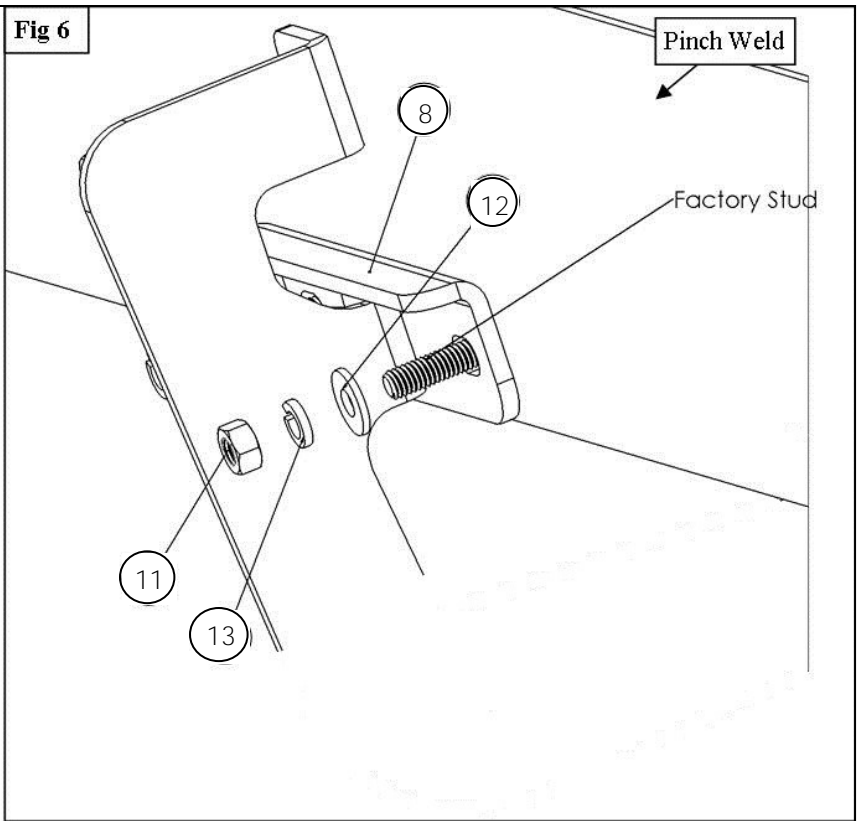
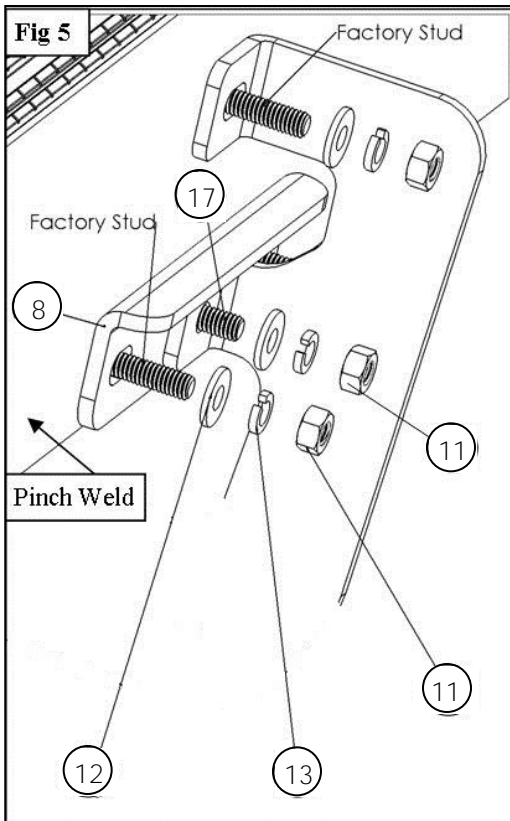

6. At the front passenger mounting location, loosely install Mounting Bracket B (3) with preassembled Mounting Bracket Base (8). **Note:** Installation is similar to Mounting Bracket A.
7. Repeat **Steps 4-7** on the driver side of the vehicle. **Note:** Driver Front will receive Mounting Bracket A (2) rather than B.
8. Moving to the rear-most location, install the Top Isolator Bracket (5), Top Isolator Brace (6), and Bottom Isolator Bracket (7) along with the Isolator Kit (9). See **Figures 8 & 9**. You will need to first remove the bolt in the bed as shown in **Figure**



Fig. 7

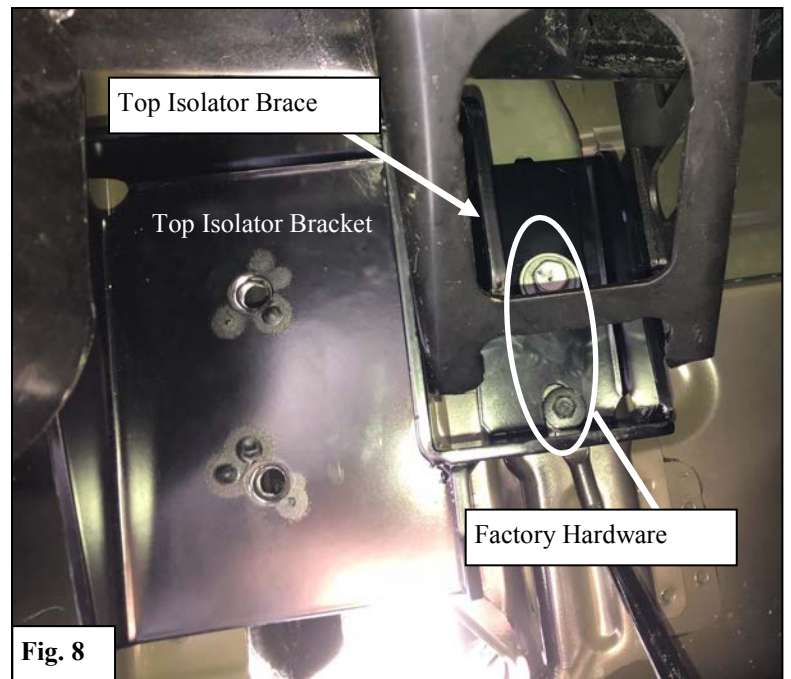

Fig. 8

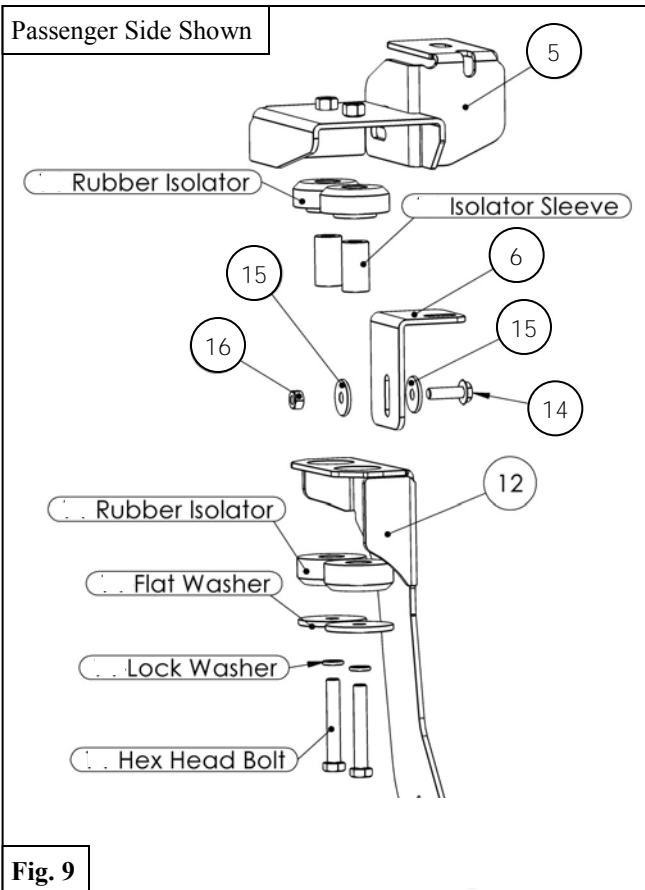

Fig. 9

9. Secure the Plastic Bracket Covers (10) to the Mounting Brackets using the supplied M6 Hardware. See **Figure 10**.
10. Fasten oval tube step bars respectively to either side using the M10 hardware provided with the step bars. See **Figure 11**.
11. Align and adjust the step bars as needed and fully tighten all hardware. Torque all M6 fasteners to 5-7 ft-lbs, all M8 fasteners to 15-18 ft-lbs, and all M10 fasteners to 30 ft-lbs.

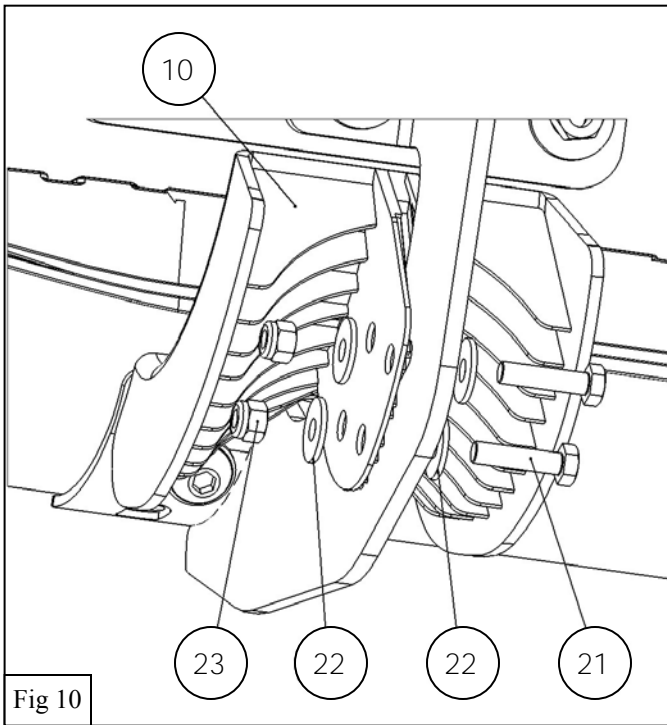

Fig 10

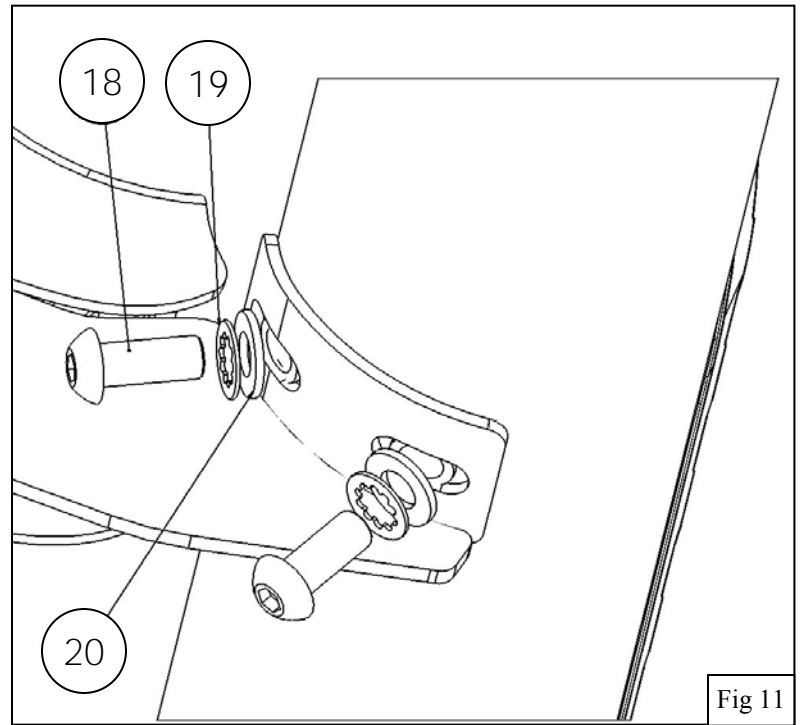
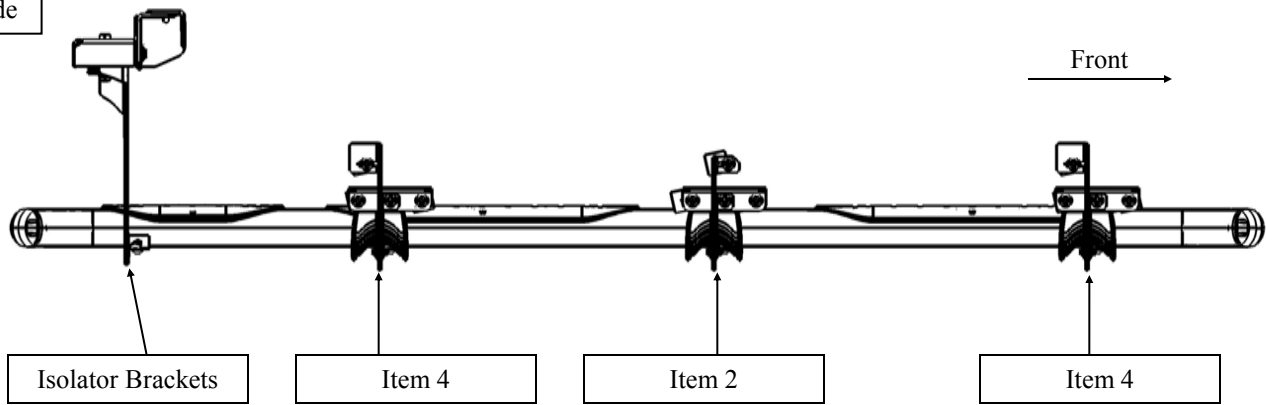
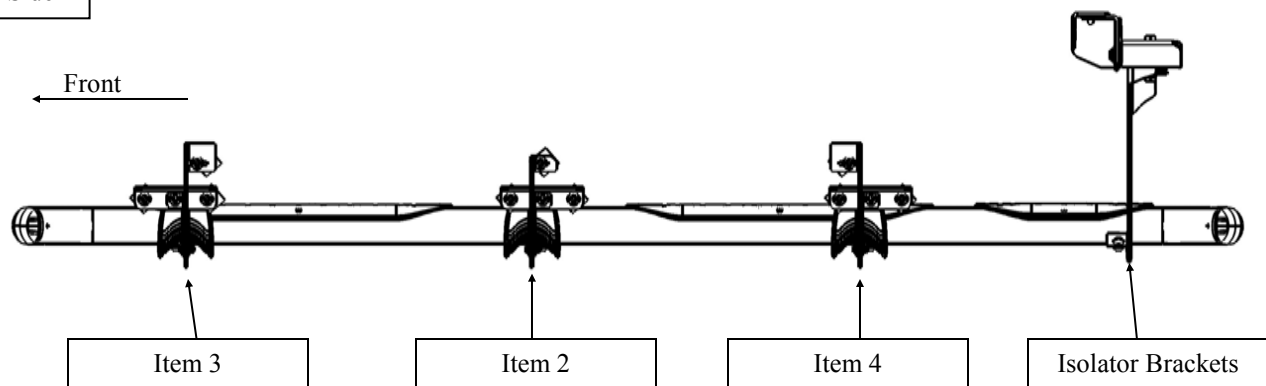

Fig 11

Driver Side



Passenger Side



INSTALLATION COMPLETE



CARE INSTRUCTIONS

- REGULAR WAXING IS RECOMMENDED. DO NOT USE ANY TYPE OF POLISH OR WAX THAT MAY CONTAIN ABRASIVES
- STAINLESS STEEL PRODUCTS CAN BE CLEANED WITH MILD SOAP AND WATER. STAINLESS STEEL POLISH SHOULD BE USED TO POLISH SMALL SCRATCHES.
- GLOSS BLACK FINISHES SHOULD BE CLEANED WITH MILD SOAP AND WATER

WESTiN



WARNING



Failure to follow these instructions could lead to death, personal injury, and / or property damage.

Failure to follow these instructions could lead to death, personal injury, and / or property damage.

FASTENERS:

All Westin supplied fasteners must be utilized and installed in accordance with the installation instructions and apply torque to the specifications as defined. **DOUBLE CHECK ALL FASTENERS BEFORE INITIAL USE, AND PERIODICALLY IN THE FUTURE TO ENSURE PROPER FUNCTION AND SAFETY.**

DRILLING:

Most Westin products do not require drilling for installation. If drilling is defined as required, use caution when drilling a vehicle. **FAILURE TO REVIEW AN AREA TO BE DRILLED MAY RESULT IN PERSONAL INJURY AND/OR INJURY TO OTHERS AS WELL AS VEHICLE DAMAGE.**

EYE PROTECTION:

ALWAYS WEAR SAFETY GLASSES OR GOGGLES DURING THE INSTALLATION PROCESS TO AVOID PERSONAL INJURY.

MAXIMUM TOWING/CARRYING CAPACITY: (if applicable)

The Westin Receiver Hitches will have a visible tow rating label affixed directly on the product. User should never exceed the vehicle manufacturers maximum tow and weight rating regardless of the capacity of the hitch. **FAILURE TO FOLLOW THESE GUIDELINES WILL VOID THE WESTIN WARRANTY AND MAY RESULT IN PERSONAL INJURY AND/OR INJURY TO OTHERS AS WELL AS VEHICLE DAMAGE.**