



# INSTALLATION INSTRUCTIONS

## PRO TRAXX 5 OVAL WHEEL TO WHEEL NERF STEP BARS

### APPLICATION:

2019 Chevrolet Silverado/GMC Sierra 1500 Crew Cab & Double Cab (6.5' Bed) (Excl. 2019 Silverado LD/Sierra 1500 Limited)

### PART NUMBER:

21-534690, 21-534695, 21-534710, 21-534715

CONTENT			
ITEM	QUANTITY	DESCRIPTION	TOOLS NEEDED
1	1	DRIVER SIDE STEP BAR ASSEMBLY	10MM SOCKET
2	1	PASSENGER SIDE STEP BAR ASSEMBLY	10MM WRENCH
3	3	DRIVER MOUNTING BRACKET	13MM SOCKET
4	3	PASSENGER MOUNTING BRACKET	13MM WRENCH
5	1	DRIVER TOP ISOLATOR MOUNT	ALLEN WRENCH
6	1	PASSENGER TOP ISOLATOR MOUNT	RATCHET
7	1	DRIVER BOTTOM ISOLATOR BRACKET	TORQUE WRENCH
8	1	PASSENGER BOTTOM ISOLATOR BRACKET	
9	2	ISOLATOR KIT	
10	8	PLASTIC BRACKET COVER	
11	12	M8 HEX HEAD CAP SCREW	
12	12	M8 SPLIT LOCK WASHER	
13	12	M8 FLAT WASHER	
14	16	M6 HEX HEAD CAP SCREW	
15	32	M6 FLAT WASHER	
16	16	M6 NYLOCK NUT	
17	2	M12 HEX HEAD CAP SCREW	
18	2	M12 SPLIT LOCK WASHER	
19	16	M10 BUTTON HEAD SCREW	
20	16	M10 TOOTHED LOCK WASHER	
21	16	M10 FLAT WASHER	

**ANTI-SEIZE LUBRICANT MUST BE USED ON ALL STAINLESS STEEL FASTENERS TO PREVENT THREAD DAMAGE AND GALLING**



DRIVER SIDE OPPOSITE

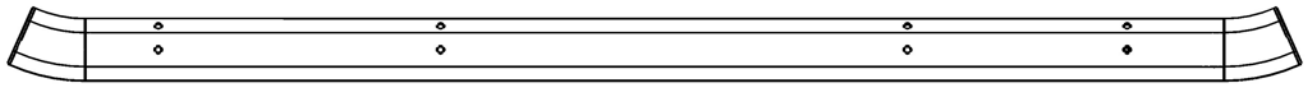

ITEM 2 (DOUBLE CAB)

DRIVER SIDE OPPOSITE

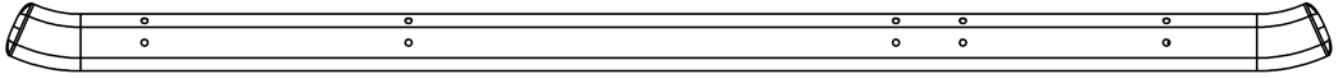

ITEM 2 (CREW CAB)

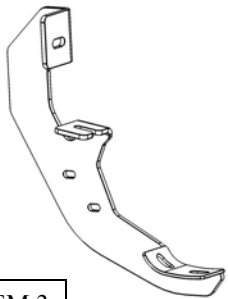

ITEM 3

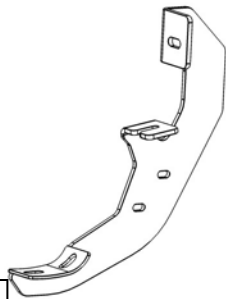

ITEM 4

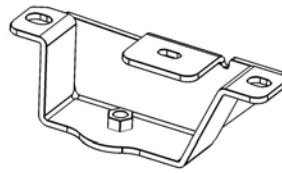

ITEM 5

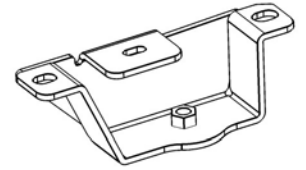

ITEM 6

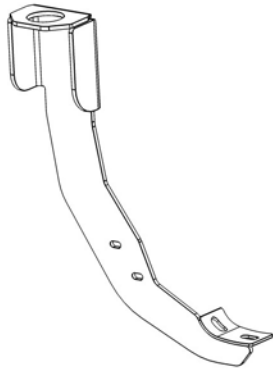

ITEM 7

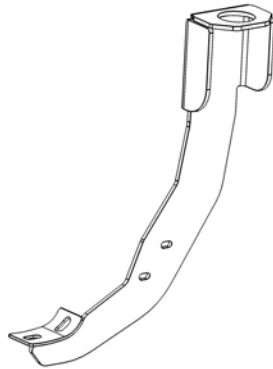

ITEM 8



ITEM 9



ITEM 10

### PROCEDURE

1. Remove contents from box, verify if all parts listed are present and free from damage. Carefully read and understand all instructions before attempting installation.  
**Failure to identify damage before installation could lead to a rejection of any claim.**

2. Starting on the driver side, remove the rubber plugs located on the rocker panel at each mounting location. See **Figure 1**.
3. **For models with threaded holes:** At each bracket mounting location on the rocker panel there should be a welded factory nut.



4. Loosely preinstall the Bracket Covers (10) to the Mounting Brackets using the included M6 Hardware. See **Figure 2**.

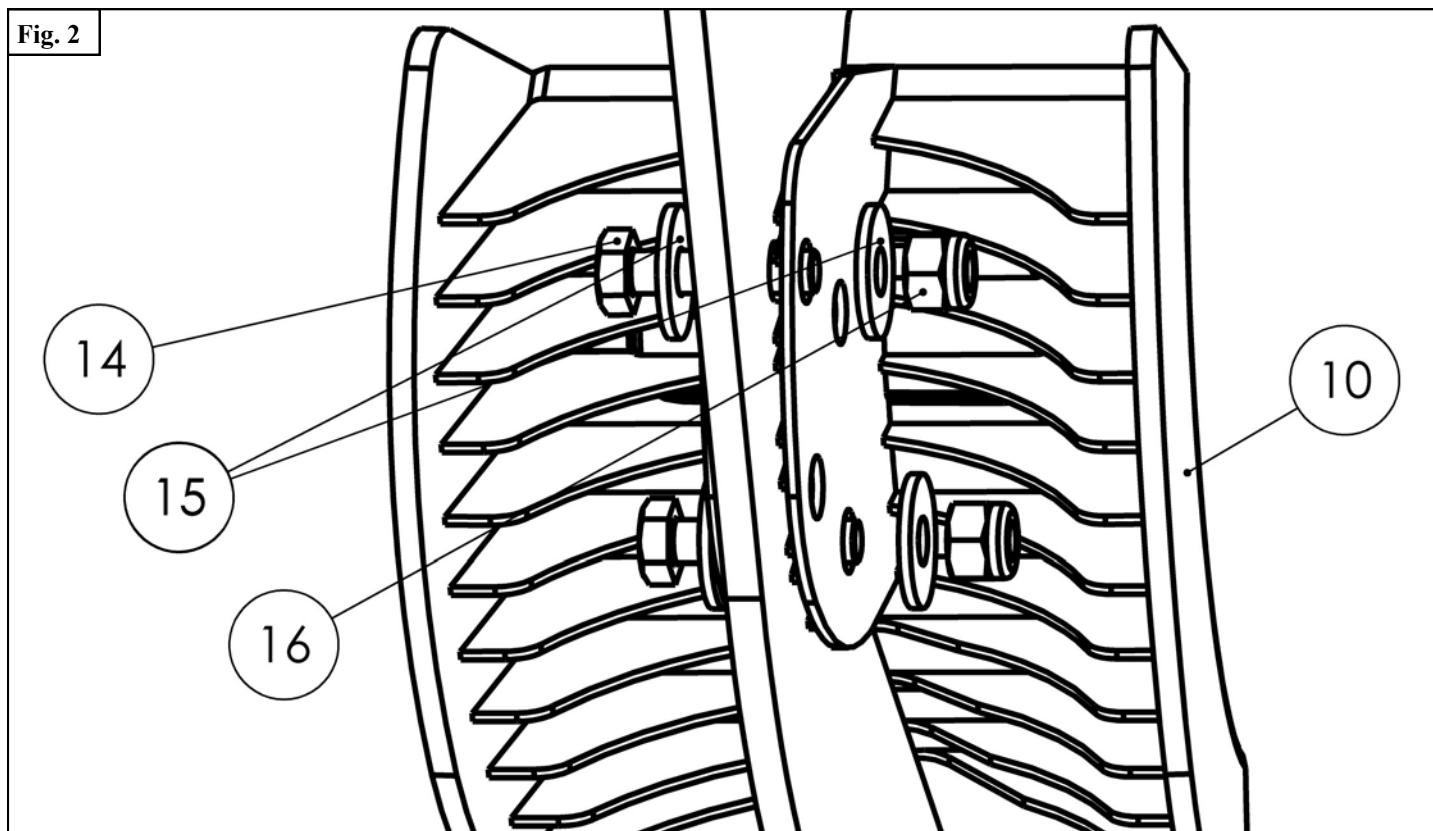

- Partially install the M8 Hardware in the bottom of the rocker panel and then slide the Mounting Brackets (3 & 4) into place and install the remaining M8 Hardware. See **Figures 3,4, & 5.**

**Note for Crew Cab Applications:** If the rocker panels are missing the rear mounting holes, use the alternate mounting location. See **Figure 4.**

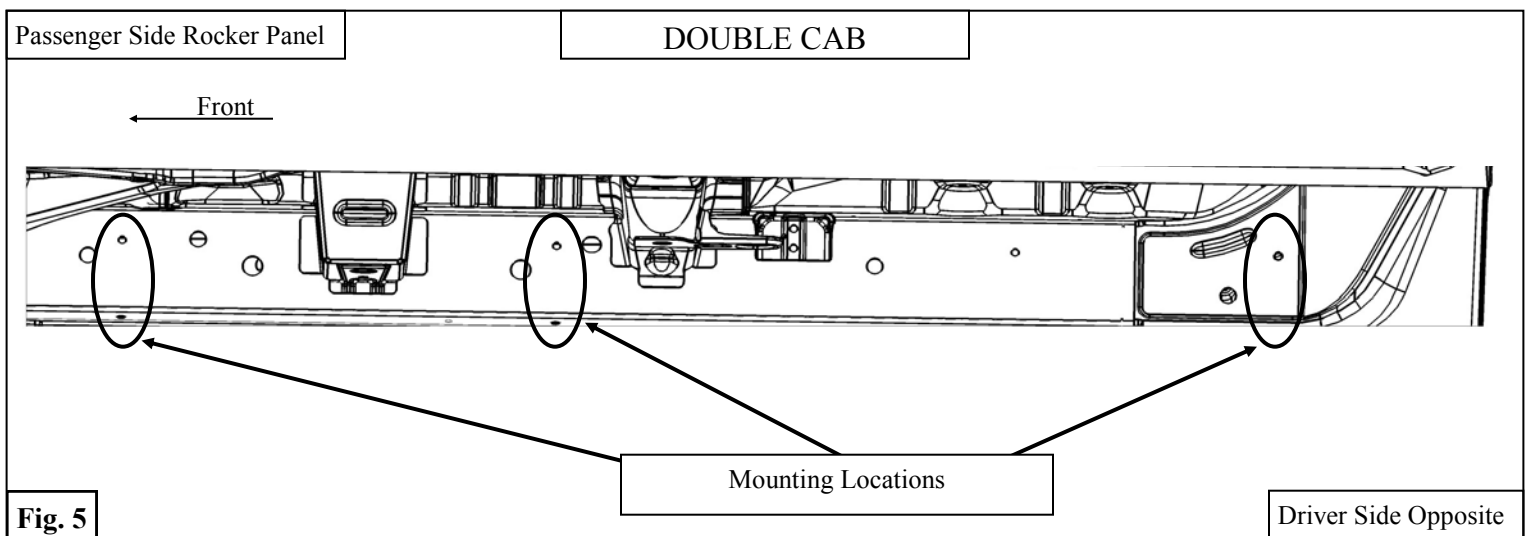
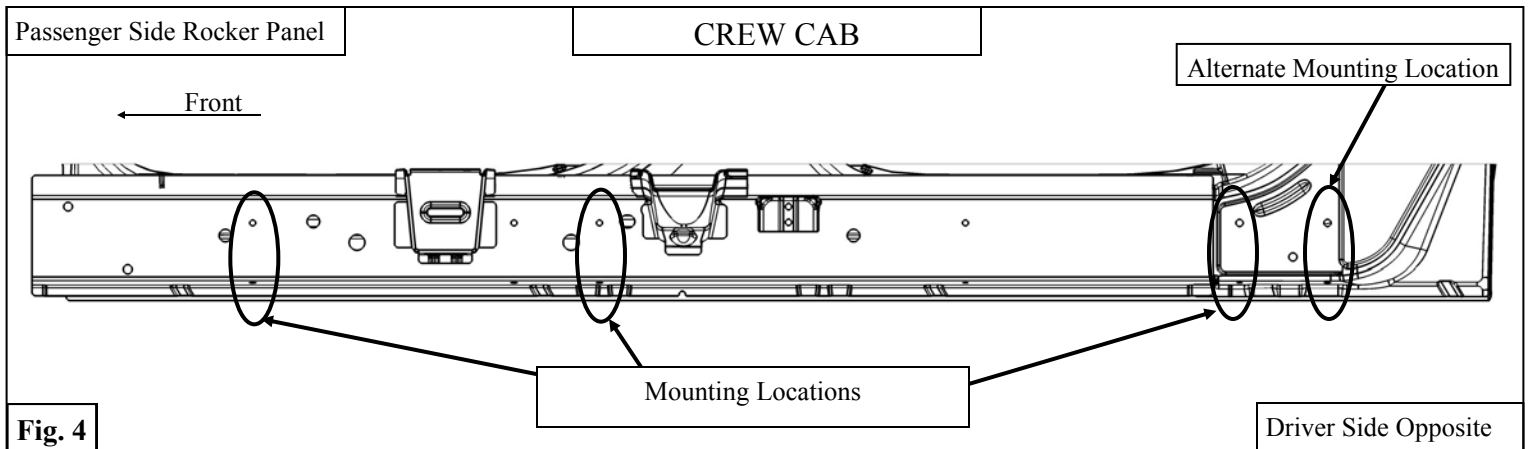
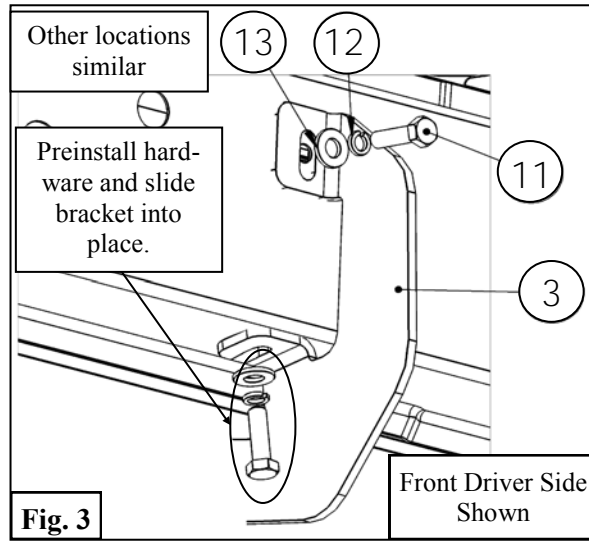

6. Remove the factory bolts attaching the bed to the frame just behind the cab. See **Figure 6**.
7. Install the Top Isolator Bracket (5,6) in this position using the factory hardware. See **Figures 6 & 7**.

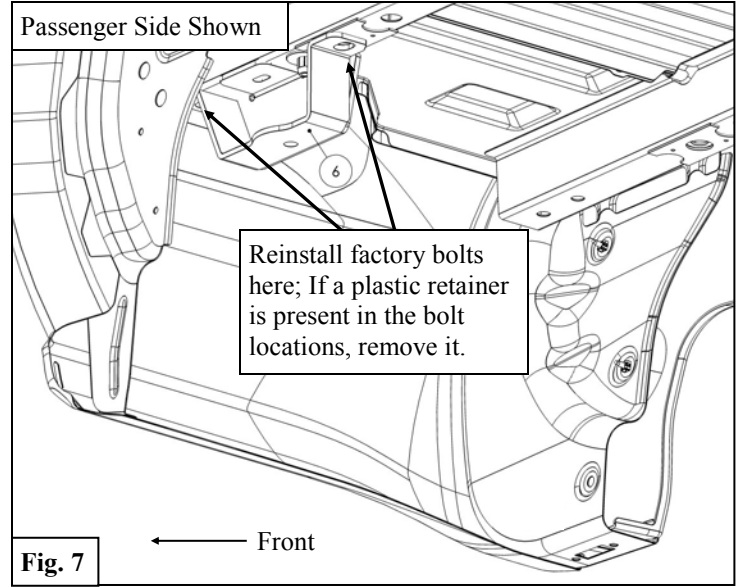
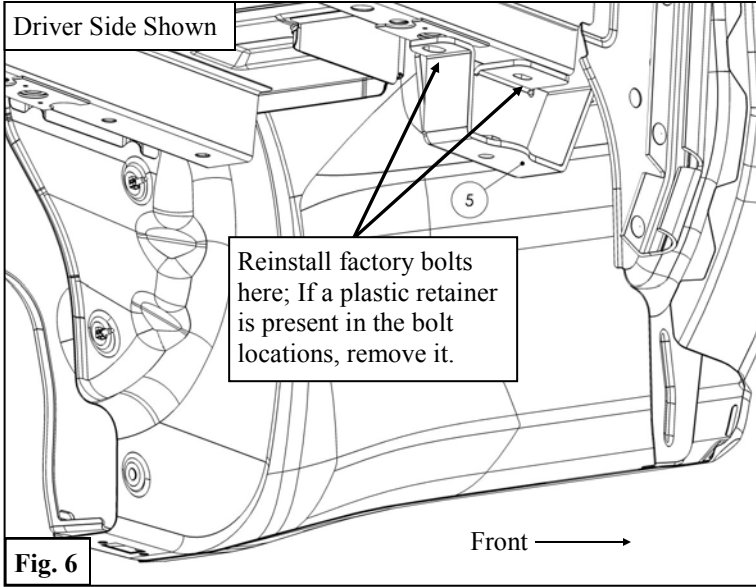

8. Install the Isolator Kit (9) and Lower Isolator Brackets (7,8) to the Top Isolator Mounts (5,6) using the supplied M12 Hardware. See **Figure 8**.
9. Fasten step bars respectively to either side using the included M10 hardware (19-21). See **Figure 9**.
10. Align and adjust the step bars as needed and fully tighten all hardware. Torque all M6 fasteners to 5-7 ft-lbs, all M8 fasteners to 15-18 ft-lbs, and all M10 fasteners to 30-35 ft-lbs.

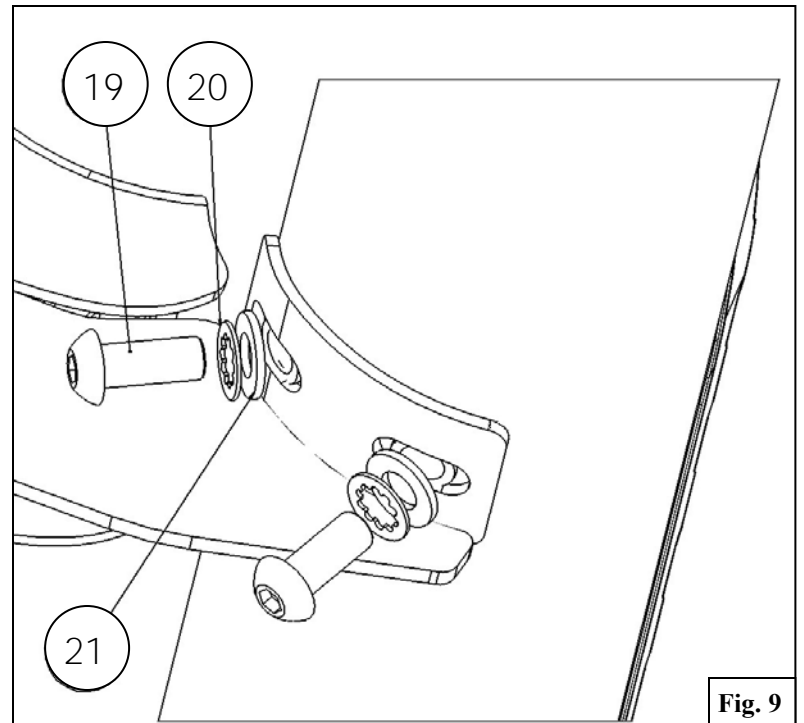
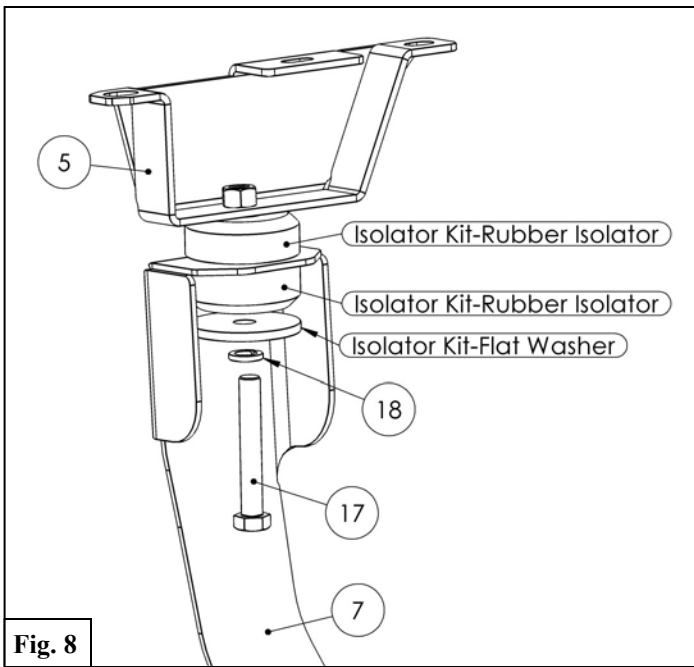

INSTALLATION COMPLETE



WESTIN AUTOMOTIVE PRODUCTS, INC. ALL RIGHTS RESERVED



## WARNING



Failure to follow these instructions could lead to death, personal injury, and / or property damage.

Failure to follow these instructions could lead to death, personal injury, and / or property damage.

### FASTENERS:

All Westin supplied fasteners must be utilized and installed in accordance with the installation instructions and apply torque to the specifications as defined. **DOUBLE CHECK ALL FASTENERS BEFORE INITIAL USE, AND PERIODICALLY IN THE FUTURE TO ENSURE PROPER FUNCTION AND SAFETY.**

### DRILLING:

Most Westin products do not require drilling for installation. If drilling is defined as required, use caution when drilling a vehicle. **FAILURE TO REVIEW AN AREA TO BE DRILLED MAY RESULT IN PERSONAL INJURY AND/OR INJURY TO OTHERS AS WELL AS VEHICLE DAMAGE.**

### EYE PROTECTION:

**ALWAYS WEAR SAFETY GLASSES OR GOGGLES DURING THE INSTALLATION PROCESS TO AVOID PERSONAL INJURY.**

### MAXIMUM TOWING/CARRYING CAPACITY: (if applicable)

The Westin Receiver Hitches will have a visible tow rating label affixed directly on the product. User should never exceed the vehicle manufacturers maximum tow and weight rating regardless of the capacity of the hitch. **FAILURE TO FOLLOW THESE GUIDELINES WILL VOID THE WESTIN WARRANTY AND MAY RESULT IN PERSONAL INJURY AND/OR INJURY TO OTHERS AS WELL AS VEHICLE DAMAGE.**