



SIGNATURE OF QUALITY

AUTOMOTIVE PRODUCTS

INSTALLATION INSTRUCTIONS

APPLICATION:

Step Pad Replacement Kit

PART NUMBER:

21-0001, 21-20001, 21-50001, 21-50002, 22-5001, 22-5002, 22-6003, 23-0001, 24-50014, 24-50020, 24-50024, 25-0001, 26-0001, 28-50001, 28-50002, 28-70001, 28-70002, 42-7005, 42-7015

ITEM	QUANTITY	DESCRIPTION	TOOLS NEEDED
1	1	STEP PAD	MALLET
2	4, 5, 6, 7, 8, 9, 10	BARREL CLIPS	PRY TOOL
3	4	M6 FLAT SOCKET HEAD BOLT (ONLY FOR 42-7005 & 42-7015)	SCREW DRIVER
4	4	M6 NYLOCK NUT (ONLY FOR 42-7005 & 42-7015)	

PROCEDURE

1. Remove contents from box, verify if all parts listed are present and free from damage.

Carefully read and understand all instructions before attempting installation.

Failure to identify damage before installation could lead to a rejection of any claim.

Note: Different step pads have different number of plastic studs, but the installation process is the same. (Figures 3-5)

Note: Step pad with Part Number 21-0001 or 24-50024 (Platinum 4") will have a plastic stud that will not need a barrel clip. This plastic stud is called the locating stud and is used to make sure the pad is installed on correctly. Refer to **Figure 3 and Platinum 4" Step Pad Assembly**. Step pad should be installed with Westin label readable when going into vehicle.

Note: Skip to Step 8 for part numbers 42-7005 and 42-7015.

- Remove the step pads with a suitable pry tool. Carefully and slowly pry off the step pad to ensure that the old barrel clips are removed from the step bar. **Note:** It is recommended want to use a rag to put in-between the pry tool and step bar to prevent scratching of step bar.
- If the barrel clips do not come off with the step pad then remove them with a Flathead screwdriver.
- Once every barrel clip has been removed place the new barrel clips in the holes in the step bar. Align the plastic studs on the step pad to the barrel clips. Refer to **Figure 1** and the **Step Pad Assembly**.
- With the clips and studs aligned start by using a mallet to softly hit the step pad in the location of the clips and studs. **Figure 2** shows the locations to be hit with a mallet. Locations are numbered from 1 to 5. Start by hitting location 1 softly followed by location 2 & 3. While hitting each location make sure that at the other locations the barrel clips and plastic studs stay aligned and in place. Repeat this by going from location 1 to 5 and at the same time correcting any misalignments. **Note:** Be sure to softly hit at locations where there are plastic studs. Start at the center and make your way out.
- Secure the step pad by hitting it firmly with the mallet in each of the locations with studs and clips.

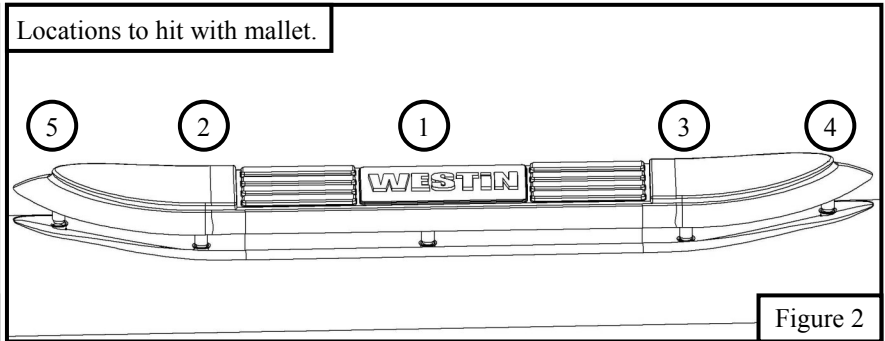
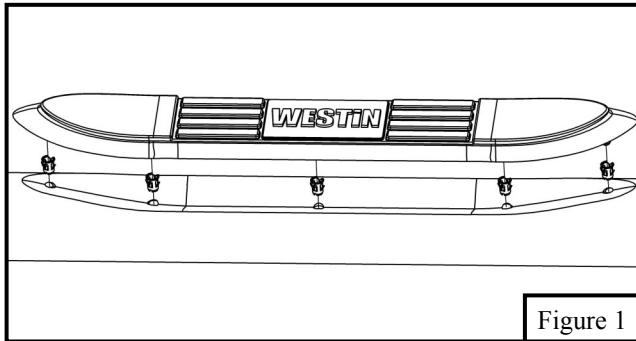

SIGNATURE OF QUALITY

8. For 42-7005 and 42-7015: Remove step pad to replace and secure new step pad using provided M6 hardware. See **Rock Slider Step Pad Assembly**. **Note:** Removal of Rockslider is necessary for installation of step plates.
9. Torque all M6 hardware to 7-9 ft-lbs.
10. Repeat for any other step pad location.
11. Reinstall step bar / rock slider if removed for installation.

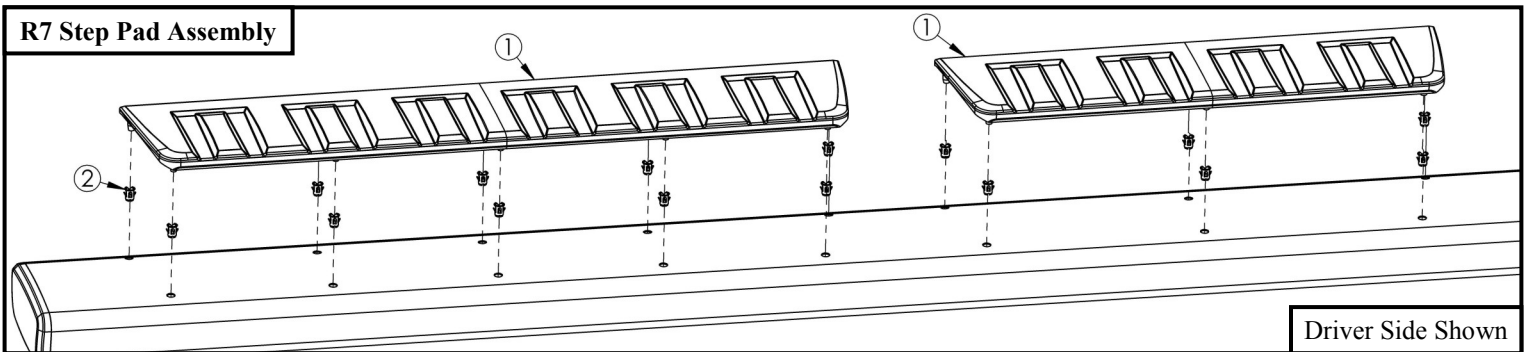
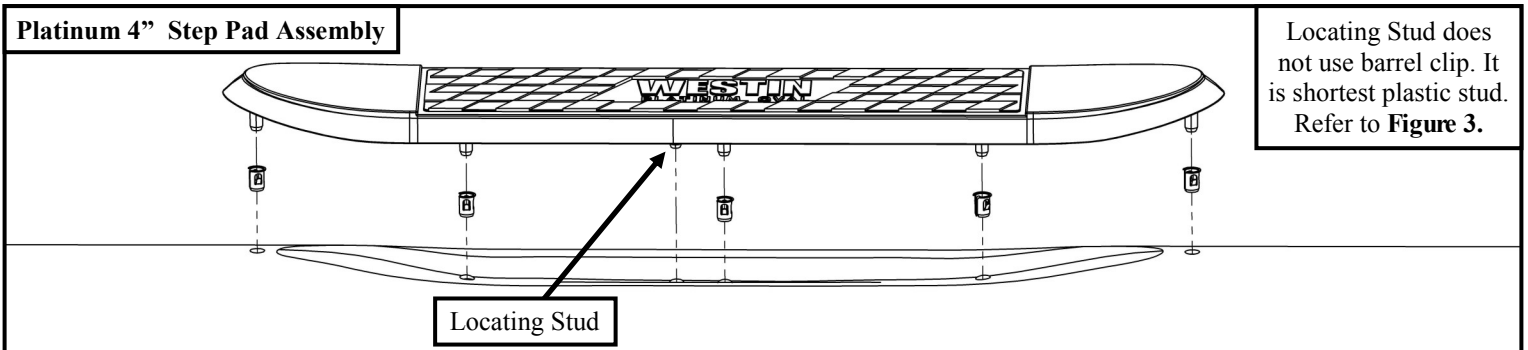
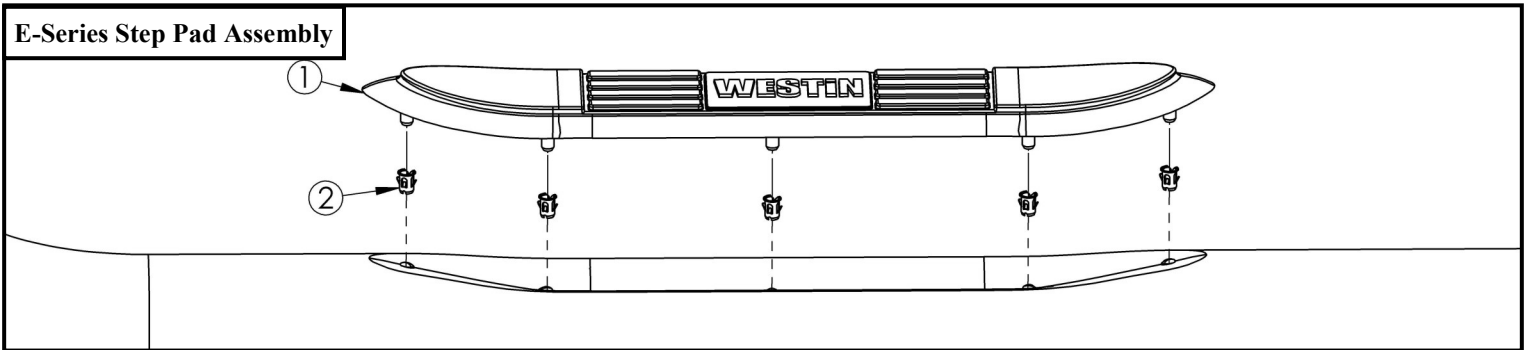
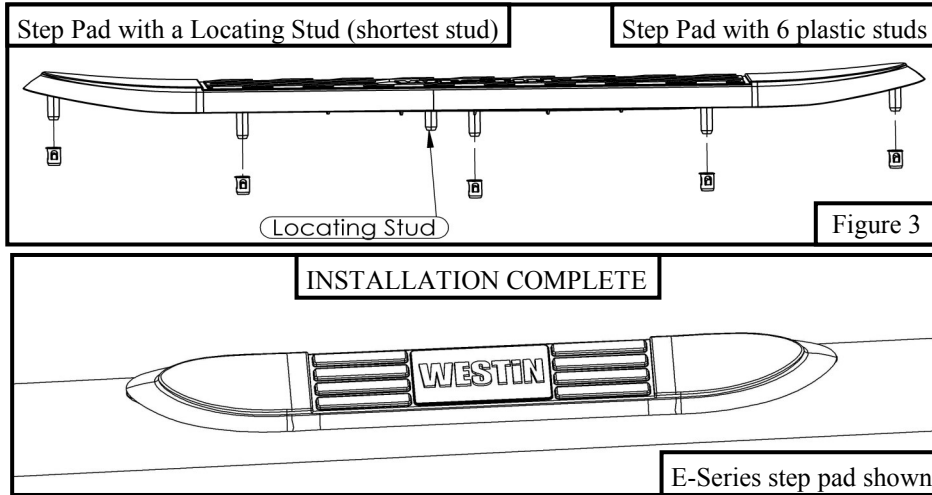

Pro Traxx 4 Step Pad Assembly

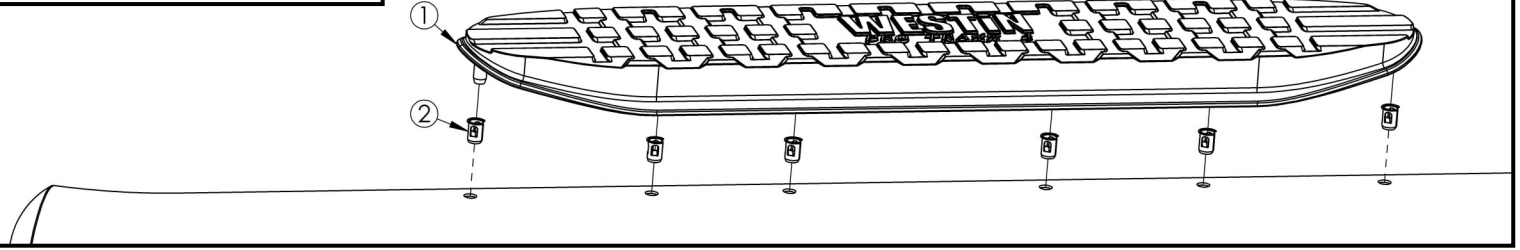

Pro Traxx 5 Step Pad Assembly

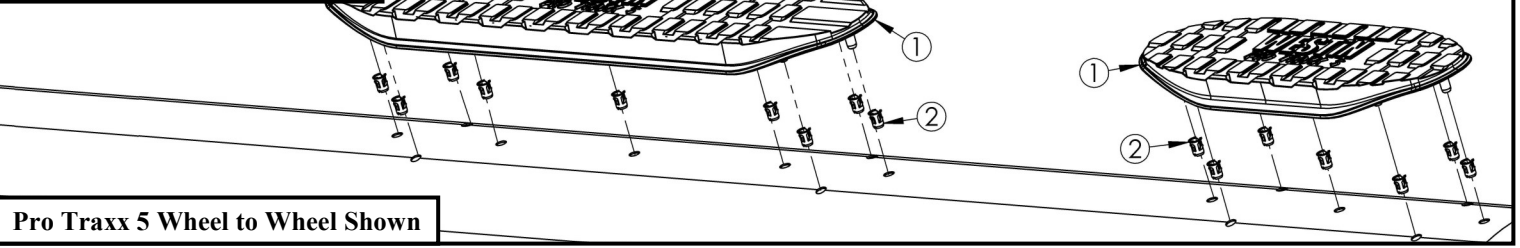

Pro Traxx 5 Wheel to Wheel Shown



6" Premier Oval Step Pad Assembly

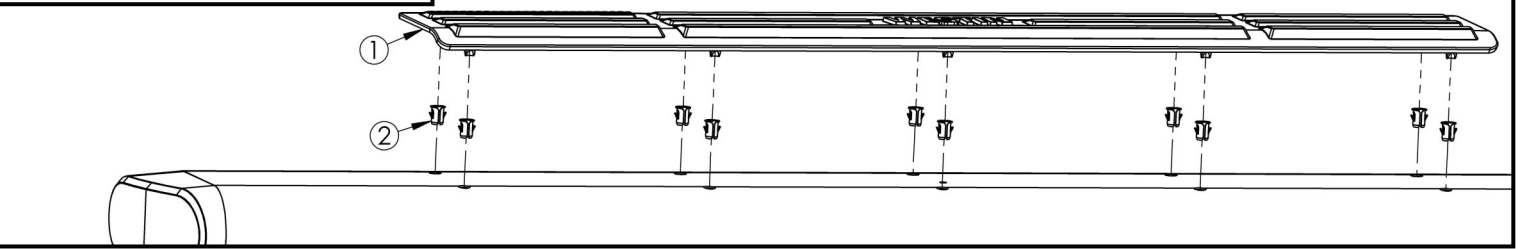

R5 Step Pad Assembly

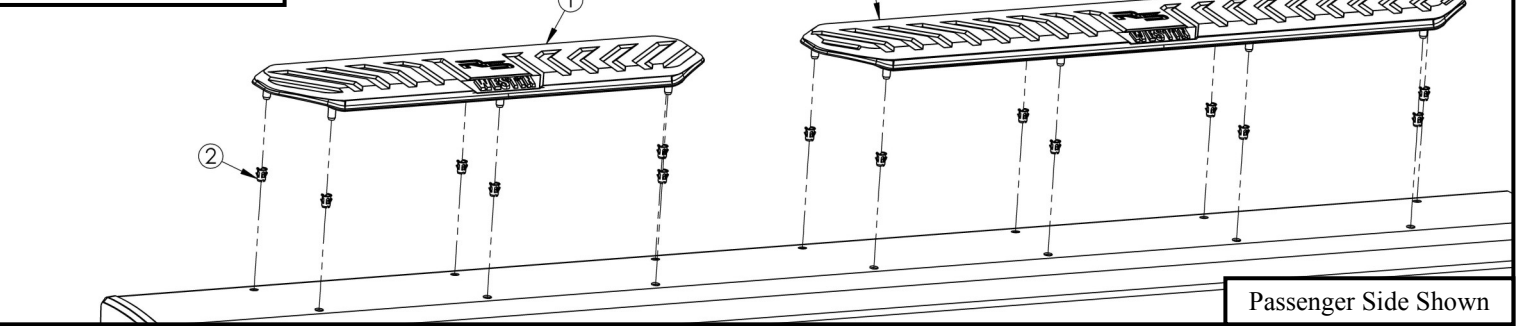

Rock Slider Step Pad Assembly

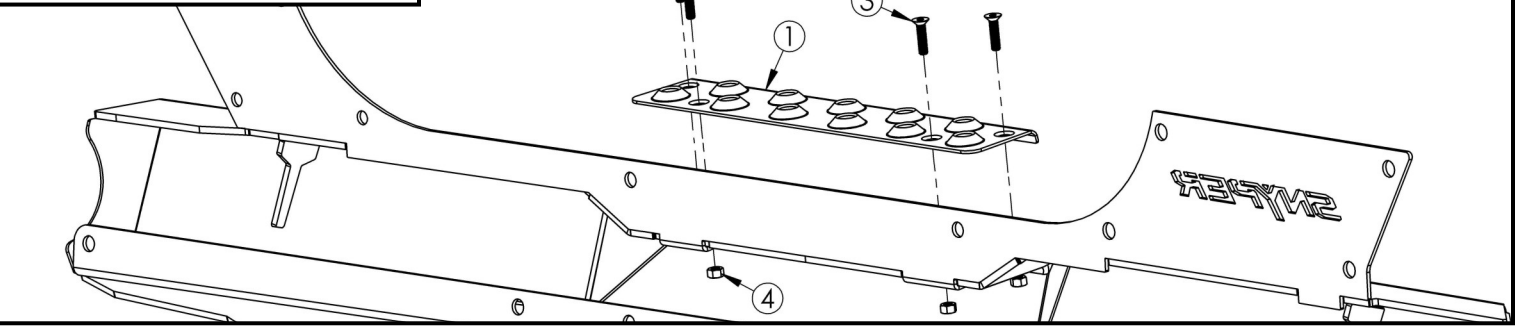

Care Instructions

- REGULAR WAXING IS RECOMMENDED. DO NOT USE ANY TYPE OF POLISH OR WAX THAT MAY CONTAIN ABRASIVES.
- STAINLESS STEEL PRODUCTS CAN BE CLEANED WITH MILD SOAP AND WATER. STAINLESS STEEL POLISH SHOULD BE USED TO POLISH SMALL SCRATCHES.
- GLOSS BLACK FINISHES SHOULD BE CLEANED WITH MILD SOAP AND WATER.

