

INSTALLATION INSTRUCTIONS

PLATINUM 4 & E-SERIES 3 NERF STEP BARS



APPLICATION:

2019 Ram 1500 Crew Cab

PART NUMBER:

21-4080, 21-4085, 23-4080 & 23-4085

CONTENT			
ITEM	QUANTITY	DESCRIPTION	TOOLS NEEDED
1,2	2	STEP BAR ASSEMBLY (1 DRIVER, 1 PASSENGER)	13MM SOCKET
3,4	2	MOUNTING BRACKET CENTER (1 DRIVER, 1 PASSENGER)	13MM WRENCH
5	2	MOUNTING BRACKET PASSENGER REAR / DRIVER FRONT	WIRE BRUSH
6	2	MOUNTING BRACKET PASSENGER FRONT / DRIVER REAR	RATCHET
7	16	M8 HEX NUT (YELLOW ZINC)	TORQUE WRENCH
8	16	M8 SPLIT LOCK WASHER (YELLOW ZINC)	ALLEN WRENCH
9	16	M8 FLAT WASHER (YELLOW ZINC)	3/4" SOCKET
10	4	1/2" HEX BOLT (YELLOW ZINC)	
11	4	1/2" FLAT WASHER (YELLOW ZINC)	
12	4	1/2" SPLIT LOCK WASHER (YELLOW ZINC)	
13	2	M10 FLAT WASHER (BLACK ZINC, S/S)	
14	2	M10 SPLIT LOCK WASHER (BLACK ZINC, S/S)	
15	2	M10 BUTTON HEAD BOLT (BLACK ZINC, S/S)	

ANTI-SEIZE LUBRICANT MUST BE USED ON ALL STAINLESS STEEL FASTENERS TO PREVENT THREAD DAMAGE AND GALLING

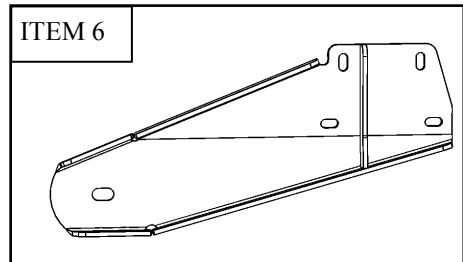
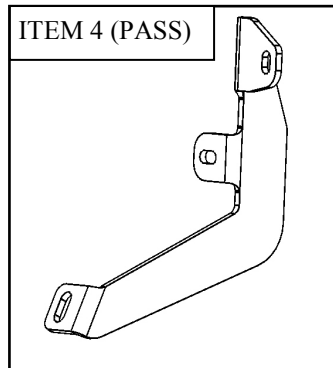
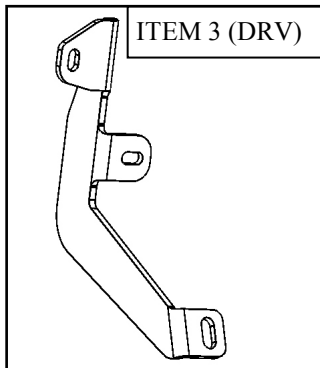
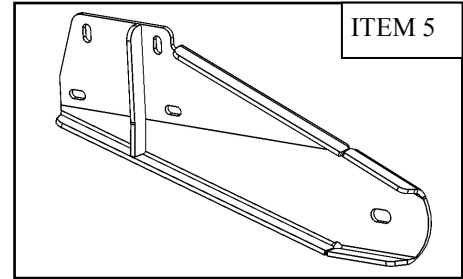
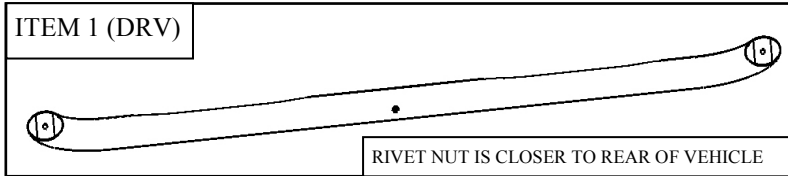

PROCEDURE

1. Remove contents from box, verify if all parts listed are present and free from damage.
Carefully read and understand all instructions before attempting installation.
Failure to identify damage before installation could lead to a rejection of any claim.

2. Loosely install the mounting brackets onto the factory rocker studs as shown in **FIGURE 1**. Note: Many trucks have excessive amounts of paint applied to the studs from the factory. If the supplied nuts do not thread on easily Westin recommends that the installer use a wire brush to knock off the excess paint. Anti-seize thread lubricant can also be used to help with this issue.

FIGURE 1

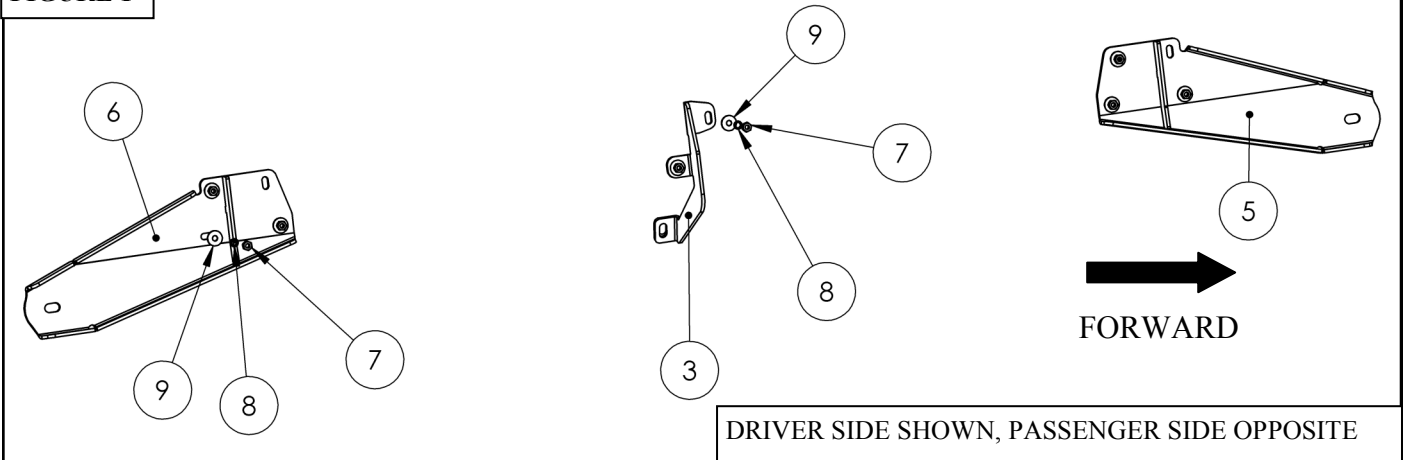

3. Loosely install the step bars onto the mounting brackets as shown in **FIGURE 2**. Note: The M10 rivet nut located on the bottom side of the step bar is approximately 2.0" biased toward the rear.

FIGURE 2

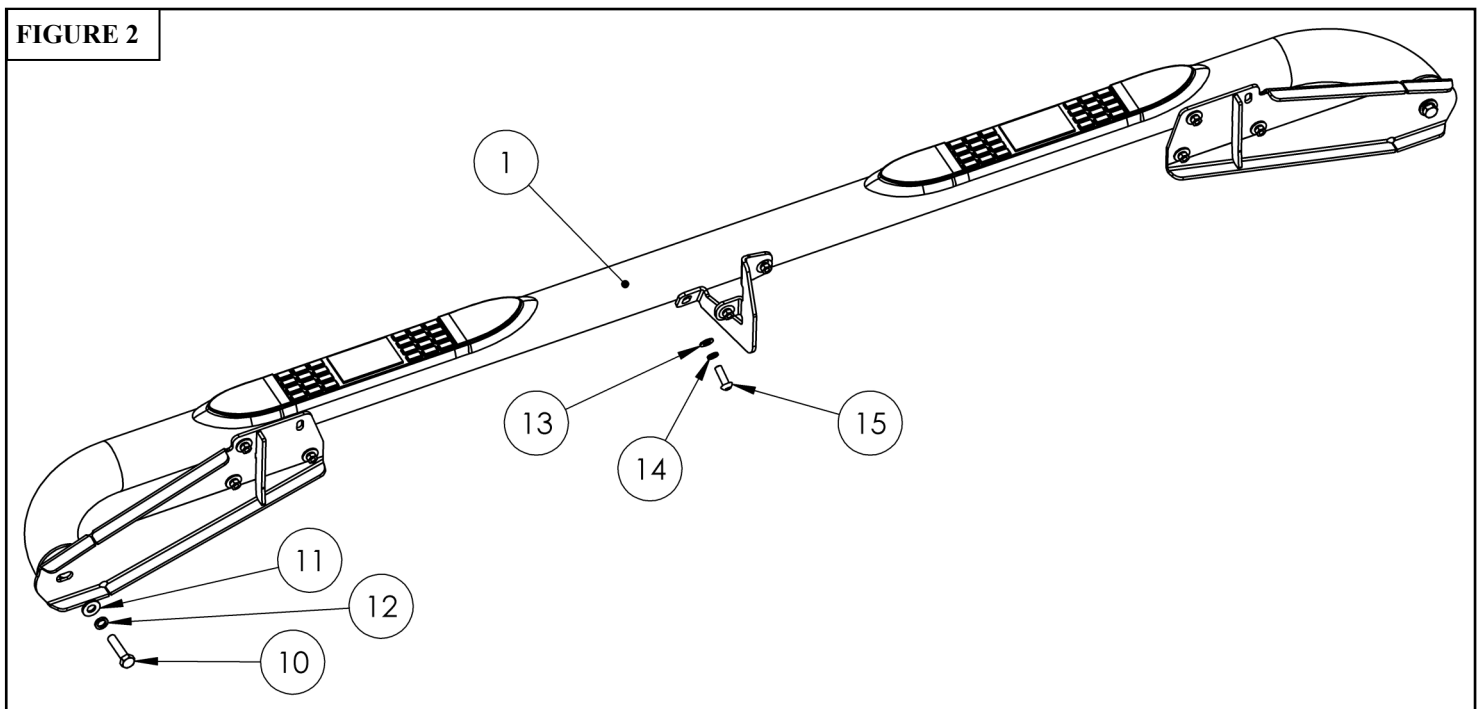

4. Align and adjust the step bars and brackets as desired then tighten all hardware. Torque fasteners as follows: M8 to 15 - 18 ft-lbs., M10 to 25 - 30 ft-lbs., 1/2" to 50 - 55 ft-lbs.





WARNING



Failure to follow these instructions could lead to death, personal injury, and / or property damage.

Failure to follow these instructions could lead to death, personal injury, and / or property damage.

FASTENERS:

All Westin supplied fasteners must be utilized and installed in accordance with the installation instructions and apply torque to the specifications as defined. **DOUBLE CHECK ALL FASTENERS BEFORE INITIAL USE, AND PERIODICALLY IN THE FUTURE TO ENSURE PROPER FUNCTION AND SAFETY.**

DRILLING:

Most Westin products do not require drilling for installation. If drilling is defined as required, use caution when drilling a vehicle. **FAILURE TO REVIEW AN AREA TO BE DRILLED MAY RESULT IN PERSONAL INJURY AND/OR INJURY TO OTHERS AS WELL AS VEHICLE DAMAGE.**

EYE PROTECTION:

ALWAYS WEAR SAFETY GLASSES OR GOGGLES DURING THE INSTALLATION PROCESS TO AVOID PERSONAL INJURY.

MAXIMUM TOWING/CARRYING CAPACITY:

The Westin Receiver Hitches will have a visible tow rating label affixed directly on the product. User should never exceed the vehicle manufacturers maximum tow and weight rating regardless of the capacity of the hitch. **FAILURE TO FOLLOW THESE GUIDELINES WILL VOID THE WESTIN WARRANTY AND MAY RESULT IN PERSONAL INJURY AND/OR INJURY TO OTHERS AS WELL AS VEHICLE DAMAGE.**



Learn more about running boards and step bars we have.