

INSTALLATION INSTRUCTIONS

PRO TRAXX 4 & 5 NERF STEP BARS

**APPLICATION:**

2019 Ford Ranger SuperCrew, 2019 Ford Ranger SuperCab

PART NUMBER:

21-24150, 21-24155, 21-54150, 21-54155, 21-24140, 21-24145, 21-54140, 21-54145

| CONTENT | | | |
|----------------|-----------------|--------------------------------------|---------------------|
| ITEM | QUANTITY | DESCRIPTION | TOOLS NEEDED |
| 1 | 1 | DRIVER STEP BAR | 10MM SOCKET |
| 2 | 1 | PASSENGER STEP BAR | 10MM WRENCH |
| 3 | 1 | DRIVER FRONT BRACKET | 16MM SOCKET |
| 4 | 1 | PASSENGER FRONT BRACKET | RATCHET |
| 5 | 1 | DRIVER CENTER BRACKET | TORQUE WRENCH |
| 6 | 1 | PASSENGER CENTER BRACKET | |
| 7 | 1 | DRIVER REAR BRACKET | |
| 8 | 1 | PASSENGER REAR BRACKET | |
| 9 | 6 | BRACKET COVER | |
| 10 | 12 | M10 HEX HEAD CAP SCREW (YELLOW ZINC) | |
| 11 | 12 | M10 SPLIT LOCK WASHER (YELLOW ZINC) | |
| 12 | 12 | M10 FLAT WASHER (YELLOW ZINC) | |
| 13 | 12 | M10 BUTTON HEAD SCREW (BLACK ZINC) | |
| 14 | 12 | M10 TOOTHED LOCK WASHER (BLACK ZINC) | |
| 15 | 12 | M10 FLAT WASHER (BLACK ZINC) | |
| 16 | 12 | M6 HEX HEAD CAP SCREW (YELLOW ZINC) | |
| 17 | 24 | M6 FLAT WASHER (YELLOW ZINC) | |
| 18 | 12 | M6 NYLOCK NUT (YELLOW ZINC) | |
| 19 | 1 | HEX KEY TOOL | |

ANTI-SEIZE LUBRICANT MUST BE USED ON ALL STAINLESS STEEL FASTENERS TO PREVENT THREAD DAMAGE AND GALLING



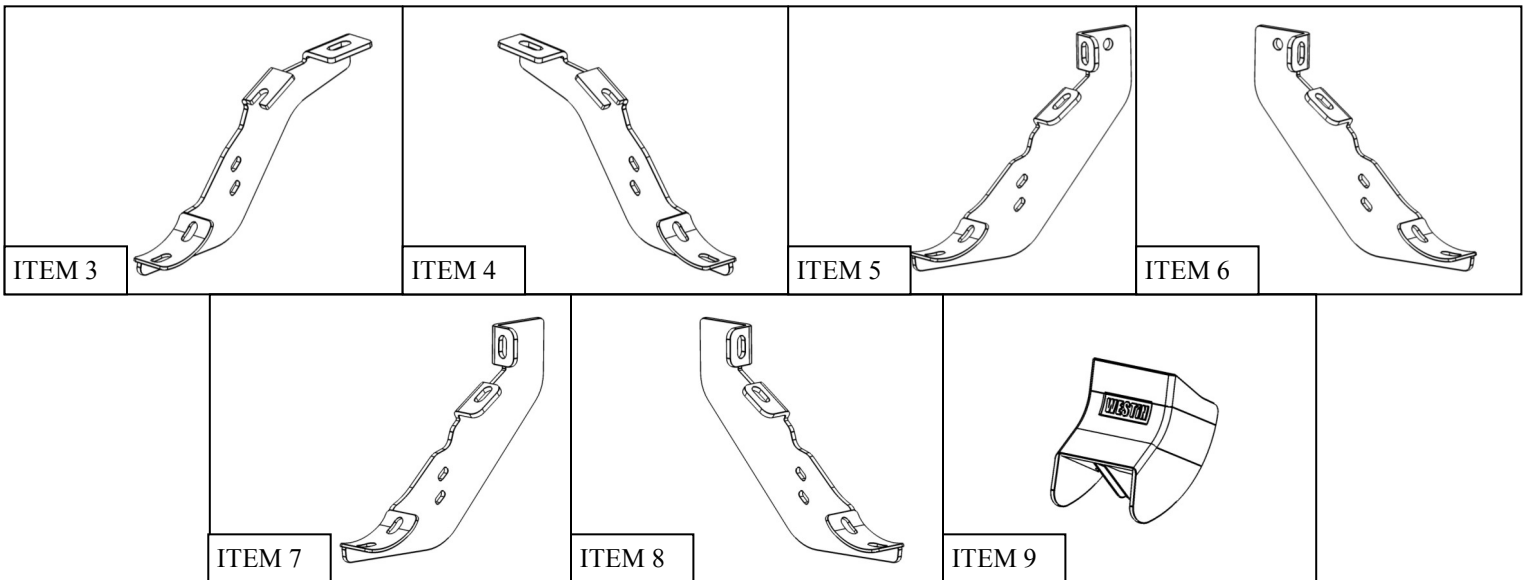
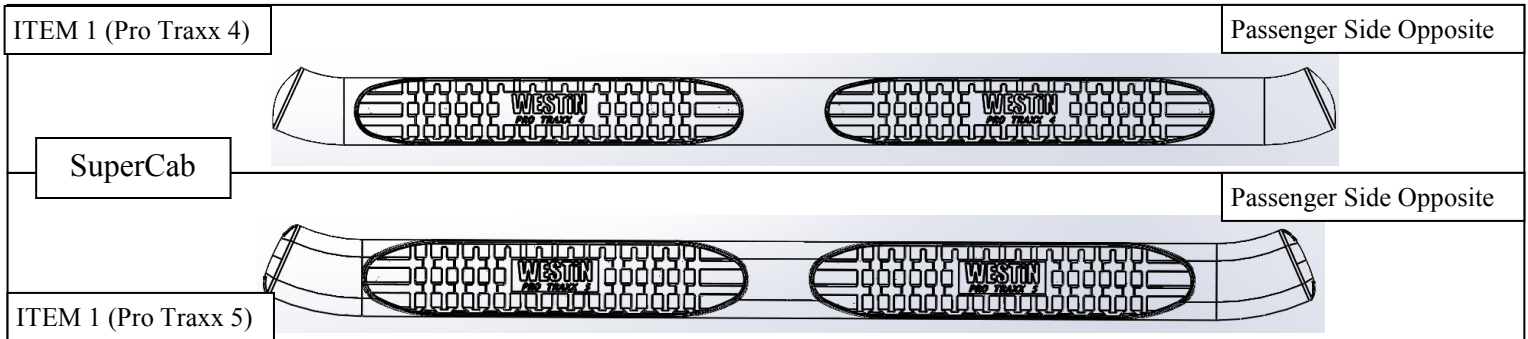
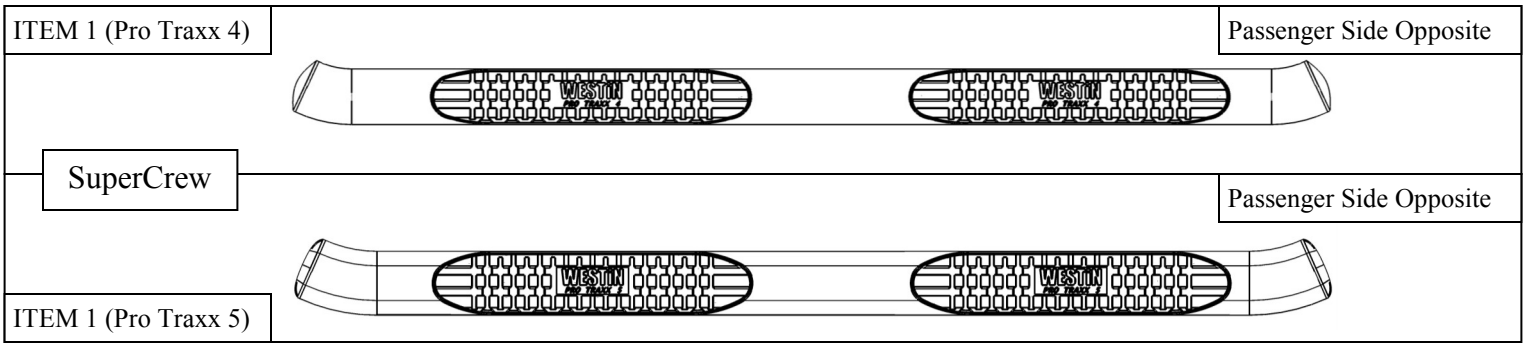

PROCEDURE

1. Remove contents from box, verify if all parts listed are present and free from damage.
Carefully read and understand all instructions before attempting installation.
Failure to identify damage before installation could lead to a rejection of any claim.

2. Beginning on the driver side of the vehicle, remove (2) M10 OEM bolts from each mounting location on the rocker panel. See **Figure 1**.

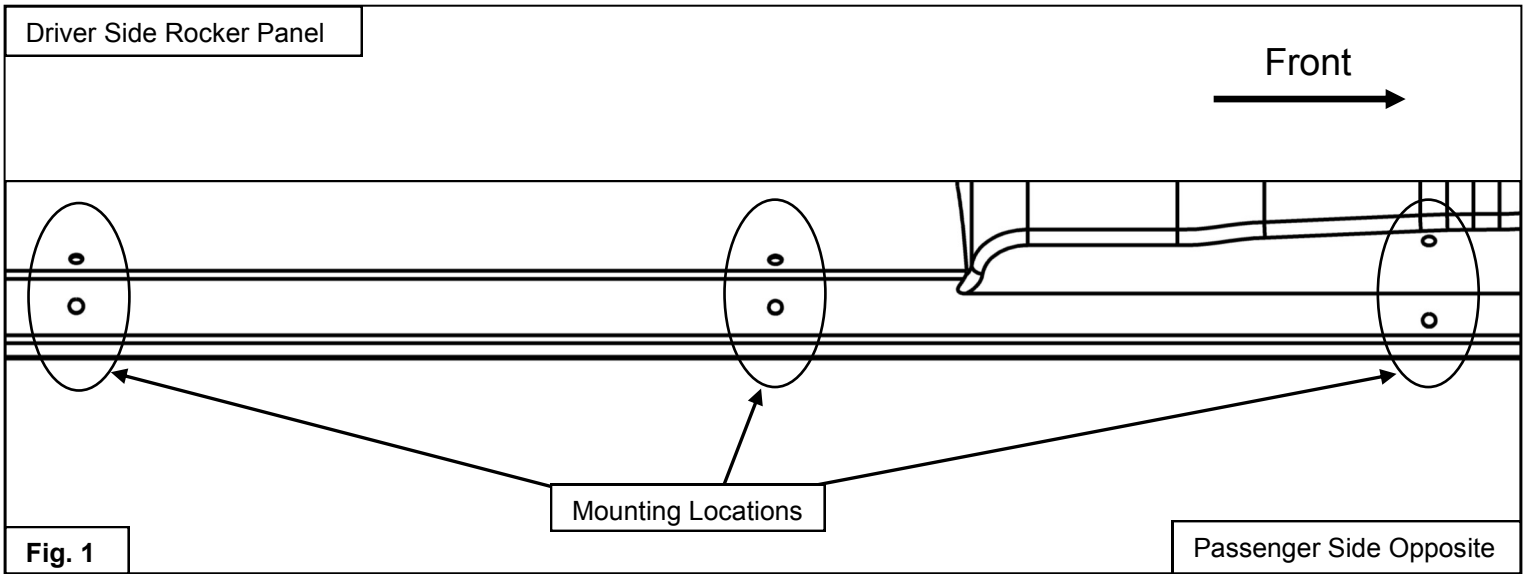

3. Loosely secure (1) Front Mount Bracket (item 3) to the rocker panel using the supplied M10 hardware. See **Figures 1 & 2**.

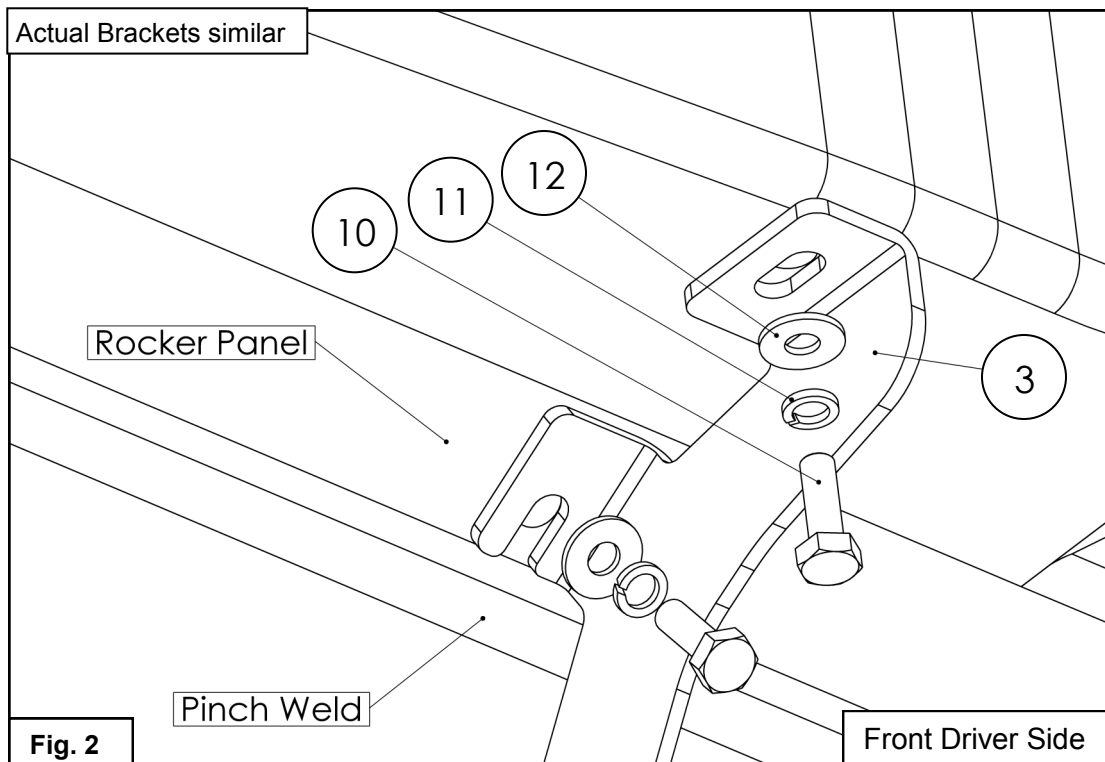

4. Loosely secure (1) Center Mount Bracket (item 5) and (1) Rear Mount Bracket (item 7) to the rocker panel using the supplied M10 hardware. See **Figures 3 & 4**.

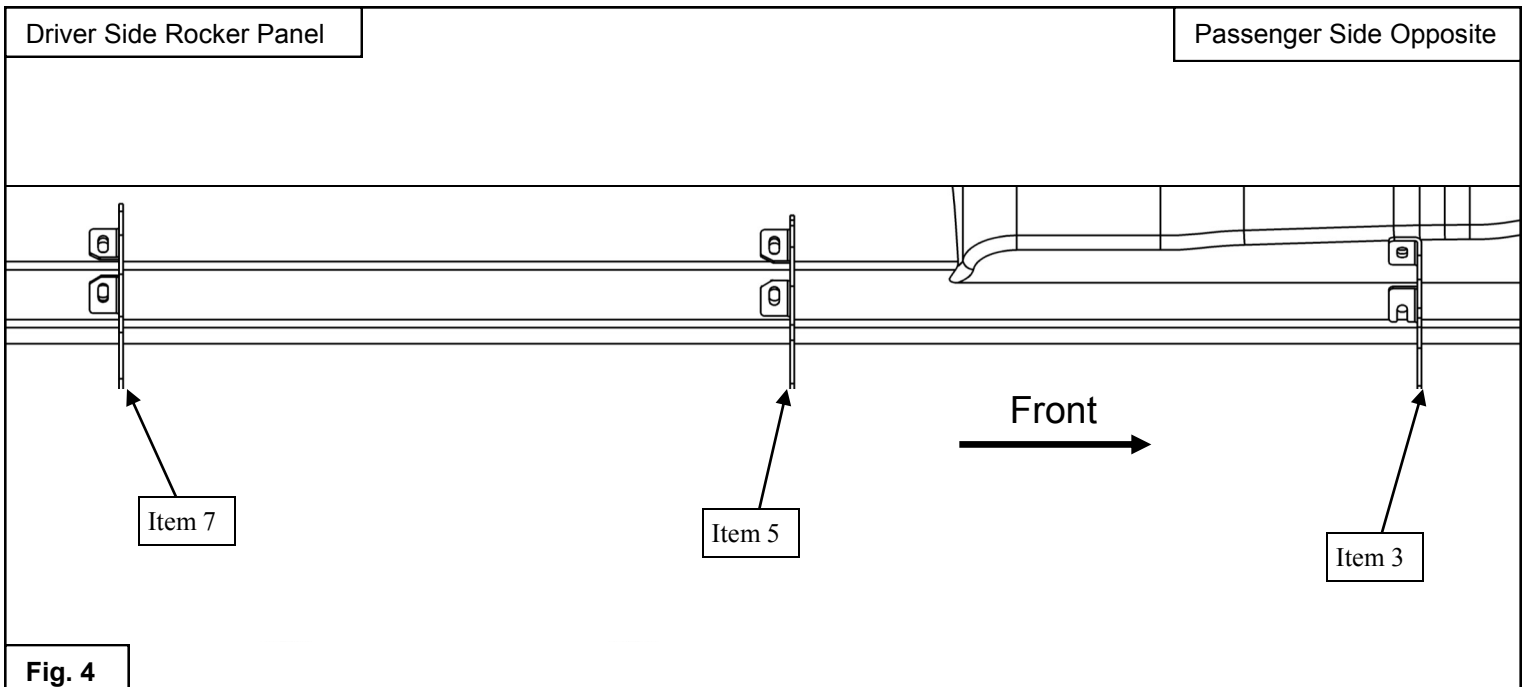
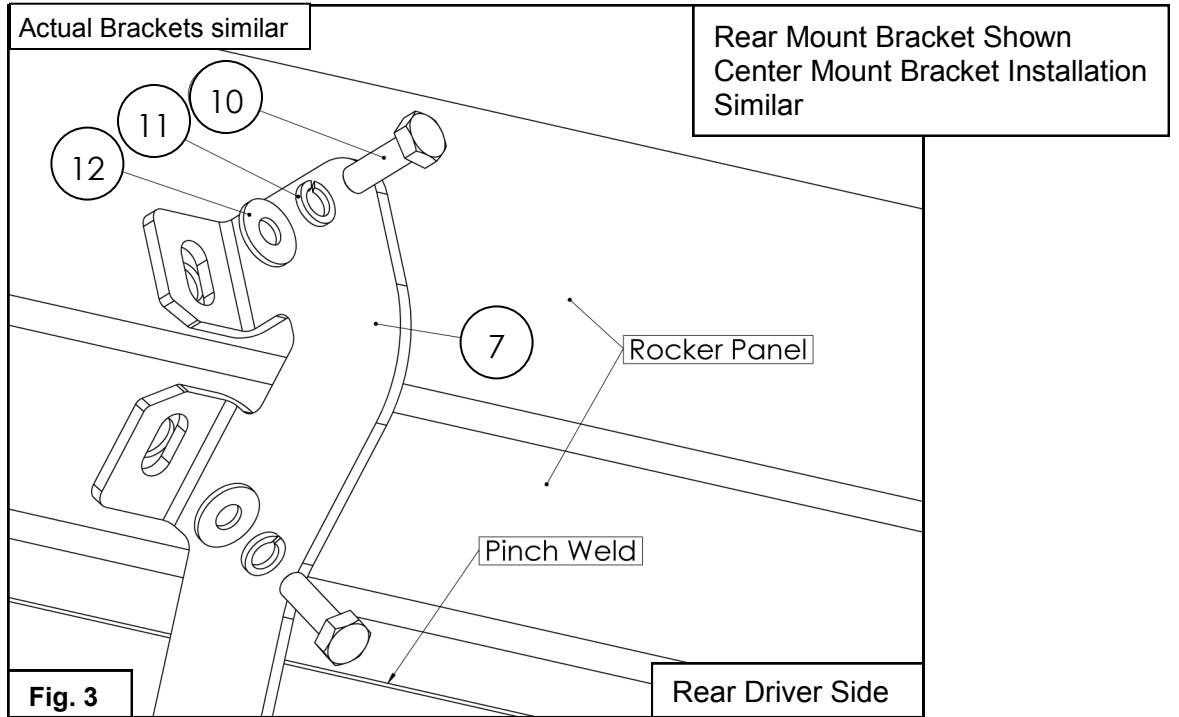

5. Use the supplied M6 Hardware to attach the Bracket Covers (9) to the Mounting Brackets (3-8). See **Figure 5**.
6. Use the supplied Black M10 Hardware to attach the Step Bras (1,2) to the Mounting Brackets (3-8). See **Figure 6**.
7. Tighten all hardware as specified: M6 to 7 ft-lbs, M10 to 38 ft-lbs.

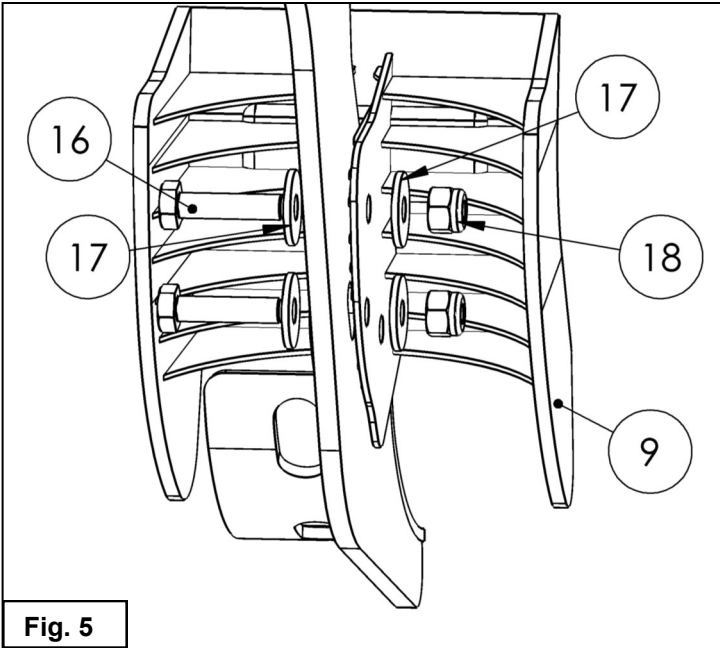

Fig. 5

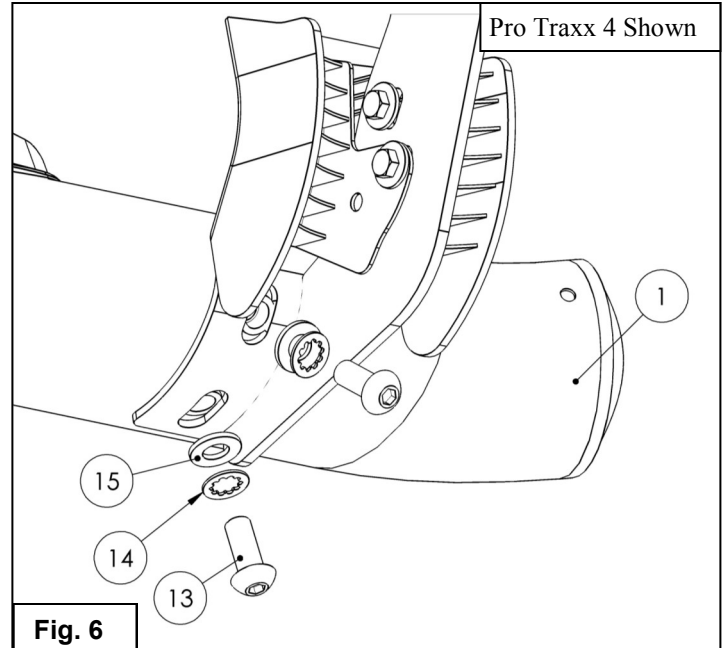

Fig. 6

INSTALLATION COMPLETE



Pro Traxx 5 Shown

CARE INSTRUCTIONS

- REGULAR WAXING IS RECOMMENDED. DO NOT USE ANY TYPE OF POLISH OR WAX THAT MAY CONTAIN ABRASIVES.
- STAINLESS STEEL PRODUCTS CAN BE CLEANED WITH MILD SOAP AND WATER. STAINLESS STEEL POLISH SHOULD BE USED TO POLISH SMALL SCRATCHES.
- GLOSS BLACK FINISHES SHOULD BE CLEANED WITH MILD SOAP AND WATER



WARNING



Failure to follow these instructions could lead to death, personal injury, and / or property damage.

Failure to follow these instructions could lead to death, personal injury, and / or property damage.

FASTENERS:

All Westin supplied fasteners must be utilized and installed in accordance with the installation instructions and apply torque to the specifications as defined. **DOUBLE CHECK ALL FASTENERS BEFORE INITIAL USE, AND PERIODICALLY IN THE FUTURE TO ENSURE PROPER FUNCTION AND SAFETY.**

DRILLING:

Most Westin products do not require drilling for installation. If drilling is defined as required, use caution when drilling a vehicle. **FAILURE TO REVIEW AN AREA TO BE DRILLED MAY RESULT IN PERSONAL INJURY AND/OR INJURY TO OTHERS AS WELL AS VEHICLE DAMAGE.**

EYE PROTECTION:

ALWAYS WEAR SAFETY GLASSES OR GOGGLES DURING THE INSTALLATION PROCESS TO AVOID PERSONAL INJURY.

MAXIMUM TOWING/CARRYING CAPACITY: (if applicable)

The Westin Receiver Hitches will have a visible tow rating label affixed directly on the product. User should never exceed the vehicle manufacturers maximum tow and weight rating regardless of the capacity of the hitch. **FAILURE TO FOLLOW THESE GUIDELINES WILL VOID THE WESTIN WARRANTY AND MAY RESULT IN PERSONAL INJURY AND/OR INJURY TO OTHERS AS WELL AS VEHICLE DAMAGE.**



Learn more about running boards and step bars we have.