

INSTALLATION INSTRUCTIONS

OUTLAW DROP NERF STEP BARS



APPLICATION:
2009-2018 Ram 1500 Crew Cab; 2019-2023 Ram 1500 Classic Crew Cab;
2010-2023 Ram 2500/3500 (Excl. Cab Chassis w/Def Tanks)

PART NUMBER:
20-13565

CONTENT			
ITEM	QUANTITY	DESCRIPTION	TOOLS NEEDED
1	2	STEP BAR ASSEMBLY	RATCHET
2	1	DRIVER FRONT MOUNTING BRACKET	TORQUE WRENCH
3	2	DRIVER CENTER/REAR MOUNTING BRACKET	10MM SOCKET
4	3	PASSENGER MOUNTING BRACKET	13MM SOCKET
5	5	M10 BOLT / M8 NUT PLATE	13MM WRENCH
6	7	M8 RIV-CERT (<i>YELLOW ZINC</i>)	15MM SOCKET
7	5	M10 HEX NUT (<i>YELLOW ZINC</i>)	15MM WRENCH
8	5	M10 SPLIT LOCK WASHER (<i>YELLOW ZINC</i>)	SOCKET EXT.
9	5	M10 FLAT WASHER (<i>YELLOW ZINC</i>)	ALLEN WRENCH
10	12	M8 HEX HEAD CAP SCREW (<i>YELLOW ZINC</i>)	
11	12	M8 SPLIT LOCK WASHER (<i>YELLOW ZINC</i>)	
12	12	M8 FLAT WASHER (<i>YELLOW ZINC</i>)	
13	2	M6 BUTTON HEAD CAP SCREW (<i>BLACK ZINC</i>)	
14	2	M6 SERRATED FLANGE NUT (<i>BLACK ZINC</i>)	
15	2	M6 FLAT WASHER (<i>BLACK ZINC</i>)	
16	5	M10 PLASTIC RETAINER SQUARE	
17	12	M10 SERRATED FLANGE HEX HEAD BOLT (<i>YELLOW ZINC</i>)	
18	12	M10 SERRATED FLANGE NUT (<i>YELLOW ZINC</i>)	

ANTI-SEIZE LUBRICANT MUST BE USED ON ALL STAINLESS STEEL FASTENERS TO PREVENT THREAD DAMAGE AND GALLING

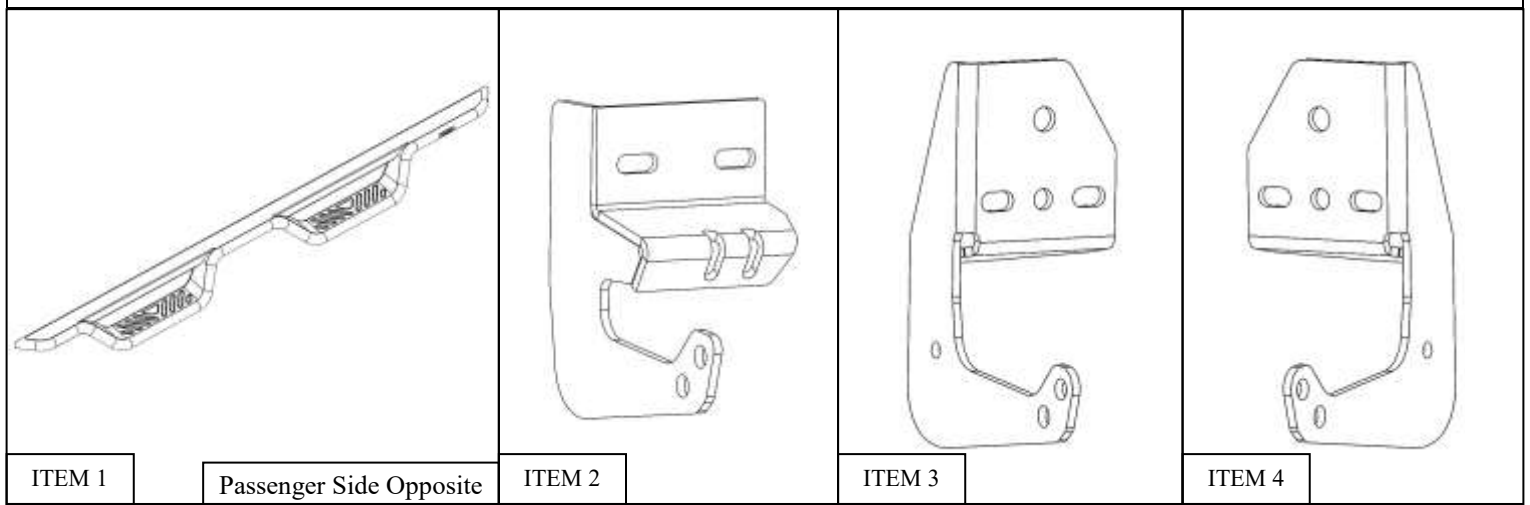

ITEM 1

Passenger Side Opposite

ITEM 2

ITEM 3

ITEM 4



Westin Automotive Products, Inc.
320 W. Covina Blvd
San Dimas, Ca. 91773

Thank You for choosing Westin products
For Additional installation assistance please call
Customer service (800) 793-7846
www.westinautomotive.com

PROCEDURE

1. Remove contents from box, verify if all parts listed are present and free from damage. Carefully read and understand all instructions before attempting installation.
Failure to identify damage before installation could lead to a rejection of any claim.
2. Starting on either side of the vehicles, locate the factory holes on the rocker panel and remove the tape. If your vehicle has threaded holes as shown in **Figure 1**, do not use the provided M8 Riv-Certs (Item 6).
3. If threaded holes are not present use (1) M8 Riv-Certs (Item 6) and insert one into the either hex hole. Insert the M10 Bolt / M8 Nut Plate (Item 5) as shown. See **Figure 2** for reference. **Note:** See **Figure 3** for instructions on how to properly install the M8 Riv-Cert using the mounting bracket. Also, the Bolt/Nut plate is not used on the driver front mounting location.

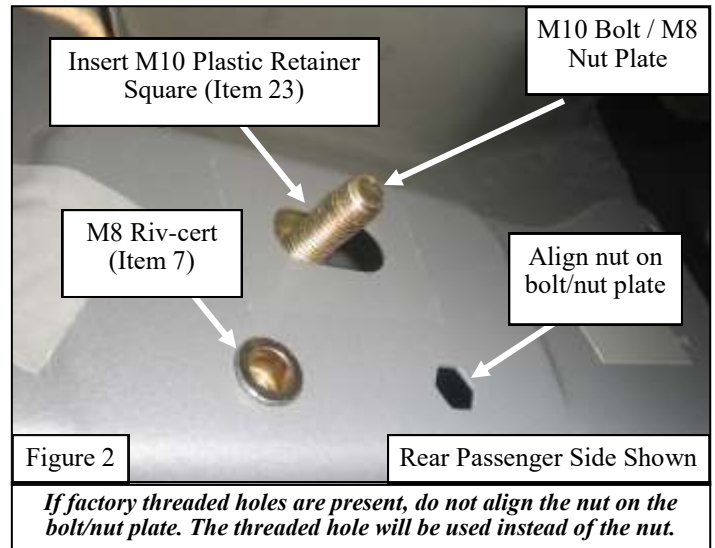
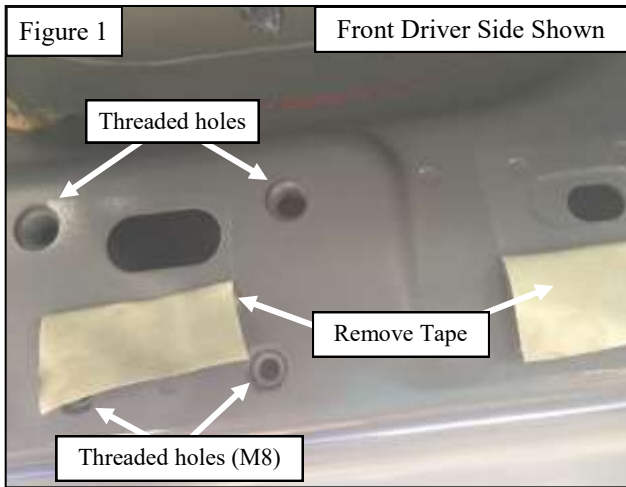

4. Proceed to install the Driver Front Mounting Bracket (Item 2) onto the rocker panel by using (2) M8 hex cap screws, (2) M8 lock washers, (2) M8 flat washers (Items 10-12). For the pinch weld, mount the bracket by using the provided M6 hardware (Items 13-15). **Note:** Drilling of two 1/4" holes might be necessary on pinch weld if factory holes are not present. Before drilling, place masking tape on drill surface to prevent any paint damage. See **Figure 4** for reference.

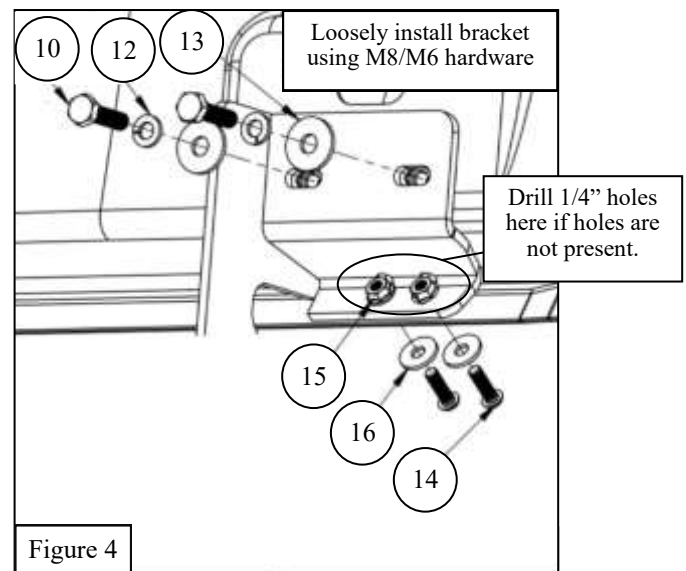
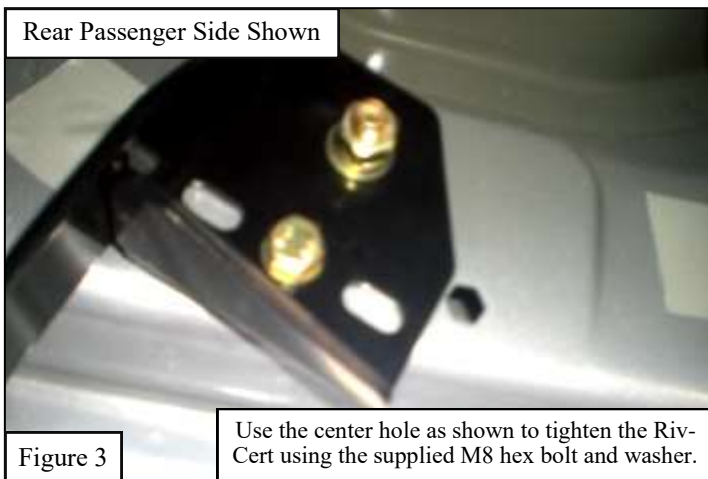

5. Loosely mount driver side Center and Rear Mounting Bracket (Item 3) to the rocker panel in the center and rear mounting locations using (2) M8 Hex Bolts, (2) M8 Lock Washers, (2) M8 Flat Washers, (1) M10 Flat Washer, (1) M10 Lock Washer, and (1) M10 Hex Nut (Items 7-12). Leave everything loosely in place at this time. See **Figure 5** for reference. **Note:** Rivcert (Item 6) will only be used when threaded holes are not present. Also, see **Figures 6 & 7** for the proper bracket orientation for both the driver and passenger side.

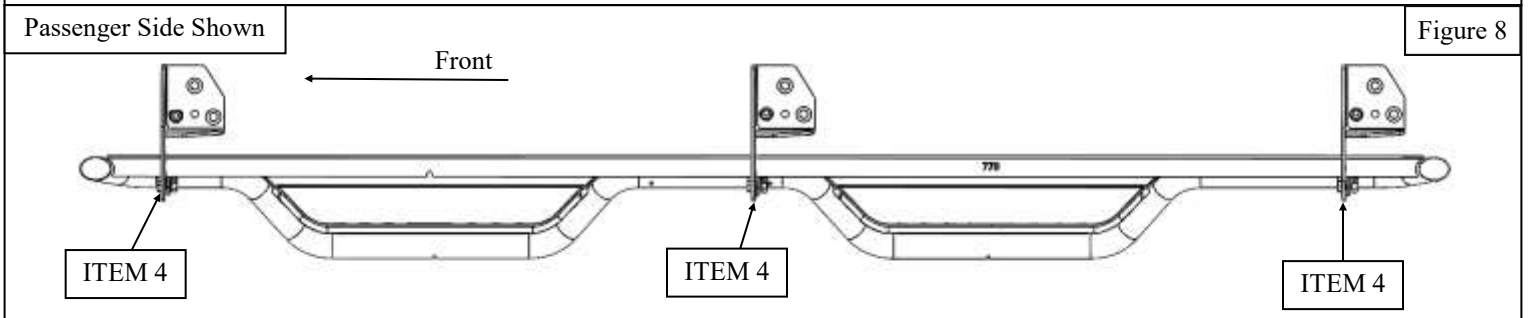
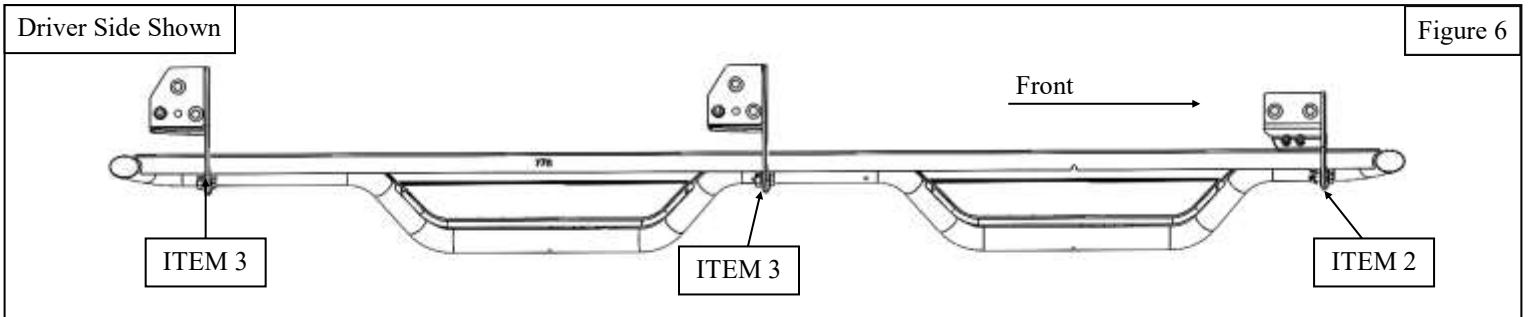
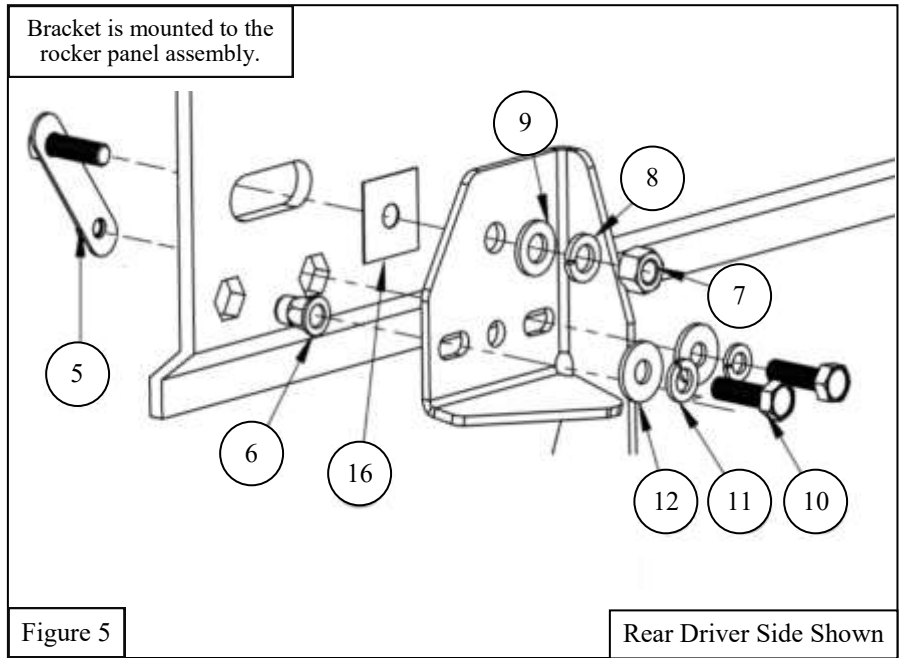

6. For the Outlaw Step Board installation, use the supplied M10 hardware to secure the step bar assembly to the previously installed mounting brackets. See **Figure 8** for reference.
7. Align and adjust the step bars and mounting brackets as necessary. Tighten and torque all hardware as specified: M8 to 15-18 ft-lbs, M10 to 35-38 ft-lbs.

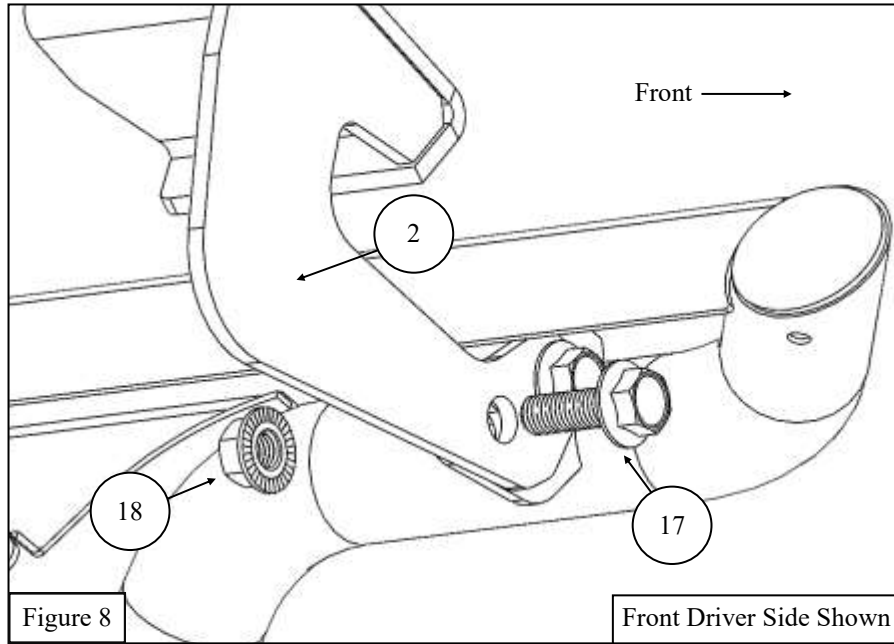

INSTALLATION COMPLETE



Care Instructions

- REGULAR WAXING IS RECOMMENDED. DO NOT USE ANY TYPE OF POLISH OR WAX THAT MAY CONTAIN ABRASIVES.
- STAINLESS STEEL PRODUCTS CAN BE CLEANED WITH MILD SOAP AND WATER. STAINLESS STEEL POLISH SHOULD BE USED TO POLISH SMALL SCRATCHES.
- GLOSS BLACK FINISHES SHOULD BE CLEANED WITH MILD SOAP AND WATER.



WARNING



Failure to follow these instructions could lead to death, personal injury, and / or property damage.

Failure to follow these instructions could lead to death, personal injury, and / or property damage.

FASTENERS:

All Westin supplied fasteners must be utilized and installed in accordance with the installation instructions and apply torque to the specifications as defined. **DOUBLE CHECK ALL FASTENERS BEFORE INITIAL USE, AND PERIODICALLY IN THE FUTURE TO ENSURE PROPER FUNCTION AND SAFETY.**

DRILLING:

Most Westin products do not require drilling for installation. If drilling is defined as required, use caution when drilling a vehicle. **FAILURE TO REVIEW AN AREA TO BE DRILLED MAY RESULT IN PERSONAL INJURY AND/OR INJURY TO OTHERS AS WELL AS VEHICLE DAMAGE.**

EYE PROTECTION:

ALWAYS WEAR SAFETY GLASSES OR GOGGLES DURING THE INSTALLATION PROCESS TO AVOID PERSONAL INJURY.

MAXIMUM TOWING/CARRYING CAPACITY: (if applicable)

The Westin Receiver Hitches will have a visible tow rating label affixed directly on the product. User should never exceed the vehicle manufacturers maximum tow and weight rating regardless of the capacity of the hitch. **FAILURE TO FOLLOW THESE GUIDELINES WILL VOID THE WESTIN WARRANTY AND MAY RESULT IN PERSONAL INJURY AND/OR INJURY TO OTHERS AS WELL AS VEHICLE DAMAGE.**

FOR CALIFORNIA RESIDENTS ONLY-PROP 65 WARNING:

Some products may contain chemicals such as DEHP, which can cause cancer, birth defects or other reproductive harm. For more info go to www.p65warnings.ca.gov



Westin Automotive Products, Inc.
320 W. Covina Blvd
San Dimas, Ca. 91773