

INSTALLATION INSTRUCTIONS

PRO MOD FRONT BUMPER



APPLICATION:
Silverado 2500/3500 2020
PART NUMBER:
58-41225

CONTENT			
ITEM	QUANTITY	DESCRIPTION	TOOLS NEEDED
1	1	CENTER SECTION	18MM SOCKET
2	1	DRIVER POD	18MM WRENCH
3	1	PASSENGER POD	19MM SOCKET
4	1	DRIVER MOUNTING BRACKET	19MM WRENCH
5	1	PASSENGER MOUNTING BRACKET	10MM SOCKET
6	1	DRIVER MOUNTING INNER BRACKET	10MM WRENCH
7	1	PASSENGER MOUNTING INNER BRACKET	15MM SOCKET
8	1	DRIVER SUPPORT STRAP	RATCHET
9	1	PASSENGER SUPPORT STRAP	TORQUE WRENCH
10	4	SENSOR TAB	PLIERS
11	4	SENSOR HOLE PLUG	UTILITY KNIFE
12	2	LED LIGHT BRACKET	
13	20	M12 FLAT WASHER	
14	10	M12 HEX HEAD BOLT	
15	10	M12 HEX NUT	
16	6	M10 HEX NUT	
17	6	M10 HEX BOLT	
18	12	M10 FLAT WASHER	
19	4	M6 HEX NUT	
20	4	M6 CARRAIGE SCREW	
21	4	M6 SPLIT LOCK WASHER	
22	4	M6 FLAT WASHER	
23	18	M6 SERRATED FLANGE NUT	
24	24	M6 FLAT WASHER (BLACK ZINC)	
25	18	M6 BUTTON HEAD BOLTS (BLACK ZINC)	
26	2	M8 FLAT WASHER (BLACK ZINC)	
27	2	M8 SERRATED FLANGE NUT	
28	2	M8 BUTTON HEAD BOLT (BLACK ZINC)	
29,30	2	MESH COVER PLATE (1 PASSENGER, 1 DRIVER)	

ANTI-SEIZE LUBRICANT MUST BE USED ON ALL STAINLESS STEEL FASTENERS TO PREVENT THREAD DAMAGE AND GALLING



CONTENT			
ITEM	QUANTITY	DESCRIPTION	TOOLS NEEDED
31		SHUTTERS BRACKET PASSENGER SIDE	
32		SHUTTERS BRACKET DRIVER SIDE	

ANTI-SEIZE LUBRICANT MUST BE USED ON ALL STAINLESS STEEL FASTENERS TO PREVENT THREAD DAMAGE AND GALLING

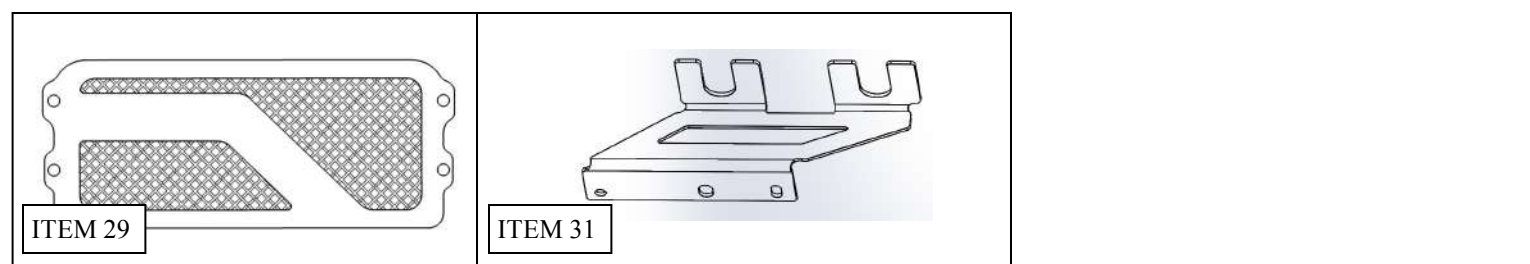
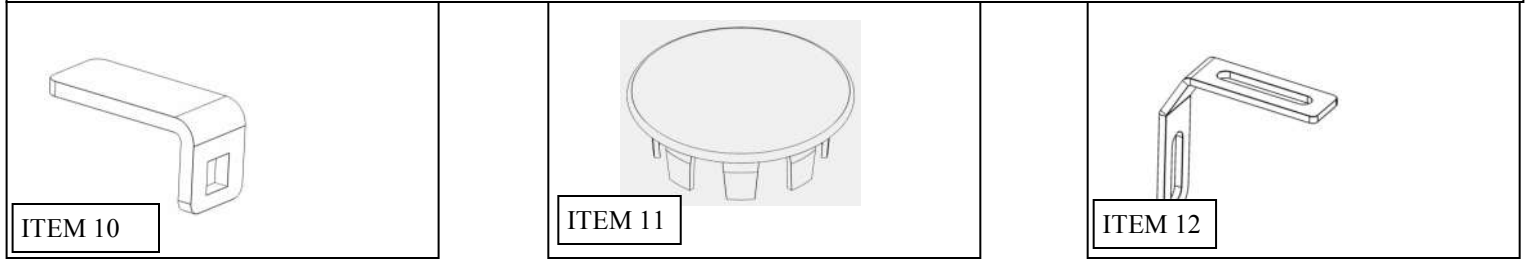
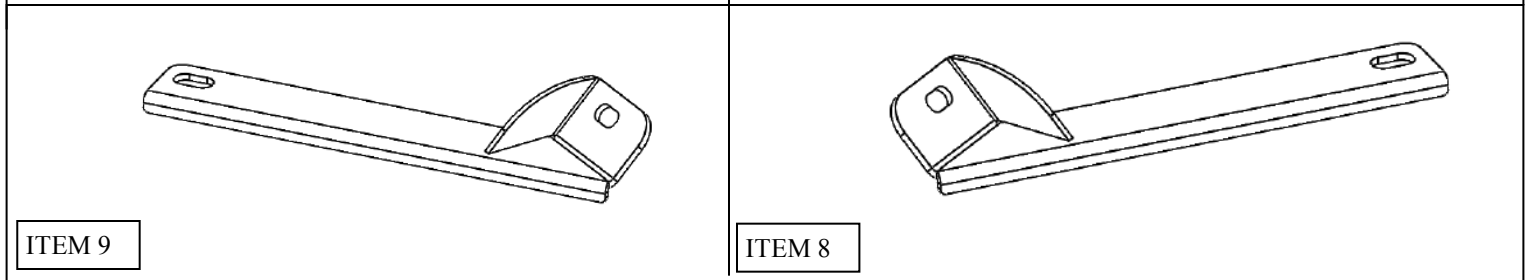
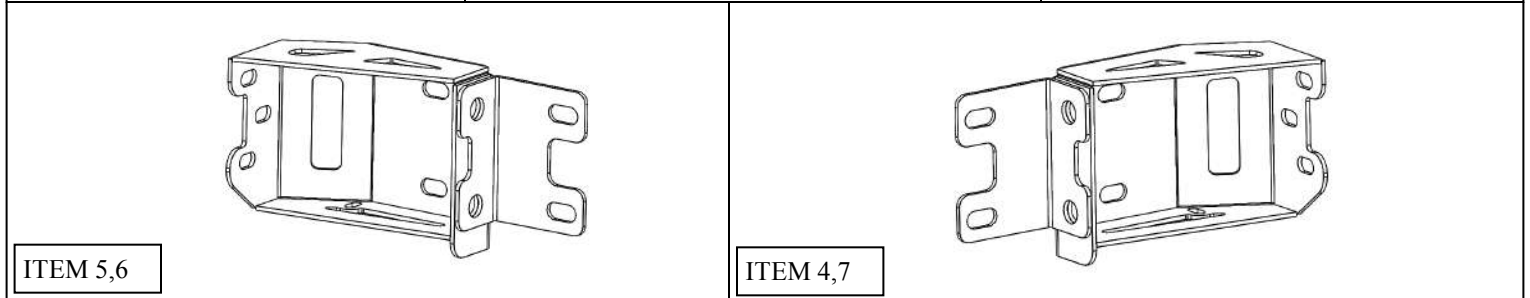
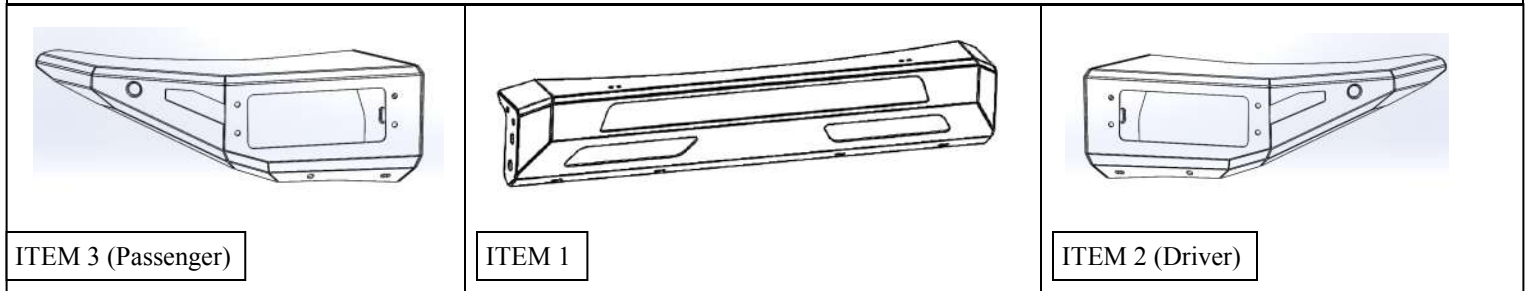

PROCEDURE

1. Remove contents from box, verify if all parts listed are present and free from damage.
Carefully read and understand all instructions before attempting installation.
Failure to identify damage before installation could lead to a rejection of any claim.

2. Open the hood of the vehicle and remove the plastic cover at the front using a pry tool. See **Figure 1**.
3. Remove the four bolts holding the grille in place. See **Figure 2**.
4. Remove 2 bolts attaching wheel well cover to filler panel. See **Figure 3**.



5. Pry off fenders to access the filler panel clips. See **Figure 4**.
6. Pry filler panel off removing any necessary bolts. See **Figure 5**.
7. Disconnect any electrical plugs and any bolts still attaching the grill to the vehicle. See **Figure 6**.
8. Pry remaining clips attaching the grill to the vehicle to remove the grille.

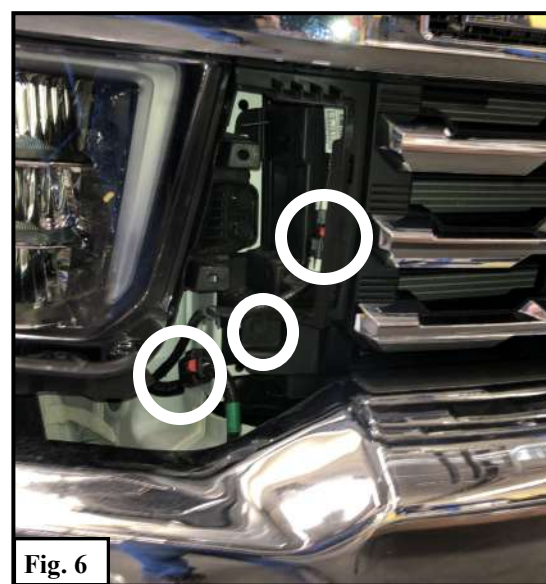
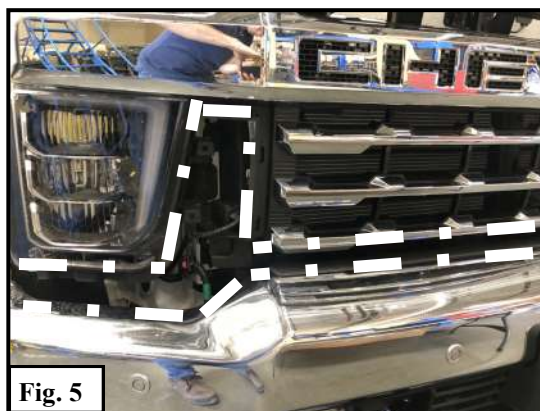
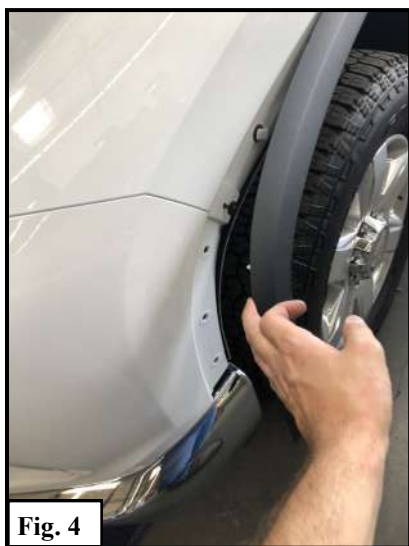

9. Remove 4 upper bumper bolts attaching the bumper to the frame and remove 2 bottom bolts attaching bumper arm to the frame. See **Figure 7 & 8**.
10. Remove Bumper.

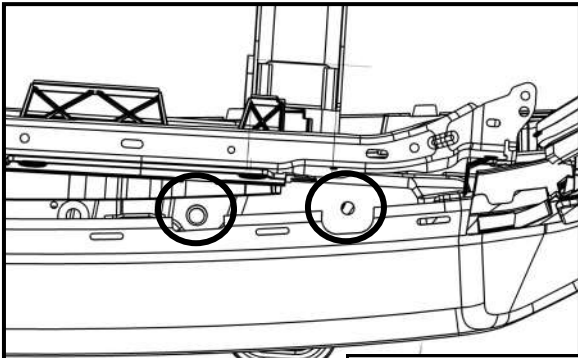

Fig. 7

Bolts will be exposed after removing the grille and lifting the plastic covering them

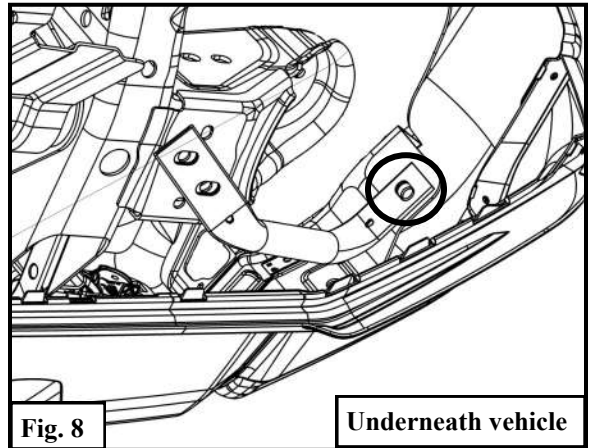

Fig. 8

Underneath vehicle

11. Remove OE bumper brackets and Aerodynamic Active Shutters. See **Figure 9**.
Note: Removal of Aerodynamic Active shutters may cause Check Engine Light to turn on. Be sure to complete steps 23 to 26.



Fig. 9

12. If equipped with parking assistance sensors, carefully remove from bumper along with wiring harness. Make sure to note orientation of sensors. This orientation has to be maintained during installation on Westin bumper.



Fig. 10

13. Use the supplied M10 Hardware (Items 16-18) to attach each Side Pod Assembly (2.3) to the Center Section (1). Align and tighten. See **Figure 11**.

14. Use the supplied M6 Hardware to attach the LED Brackets (12) to the center section. See **Figure 12** *Note: If installing an LED Light Bar (sold separately), install it at this time.*

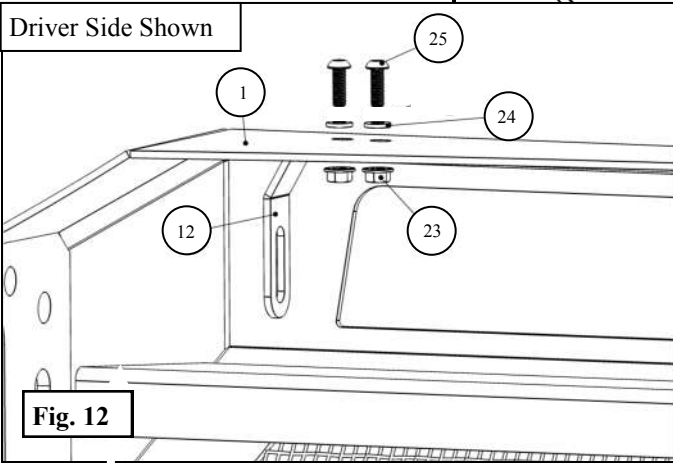
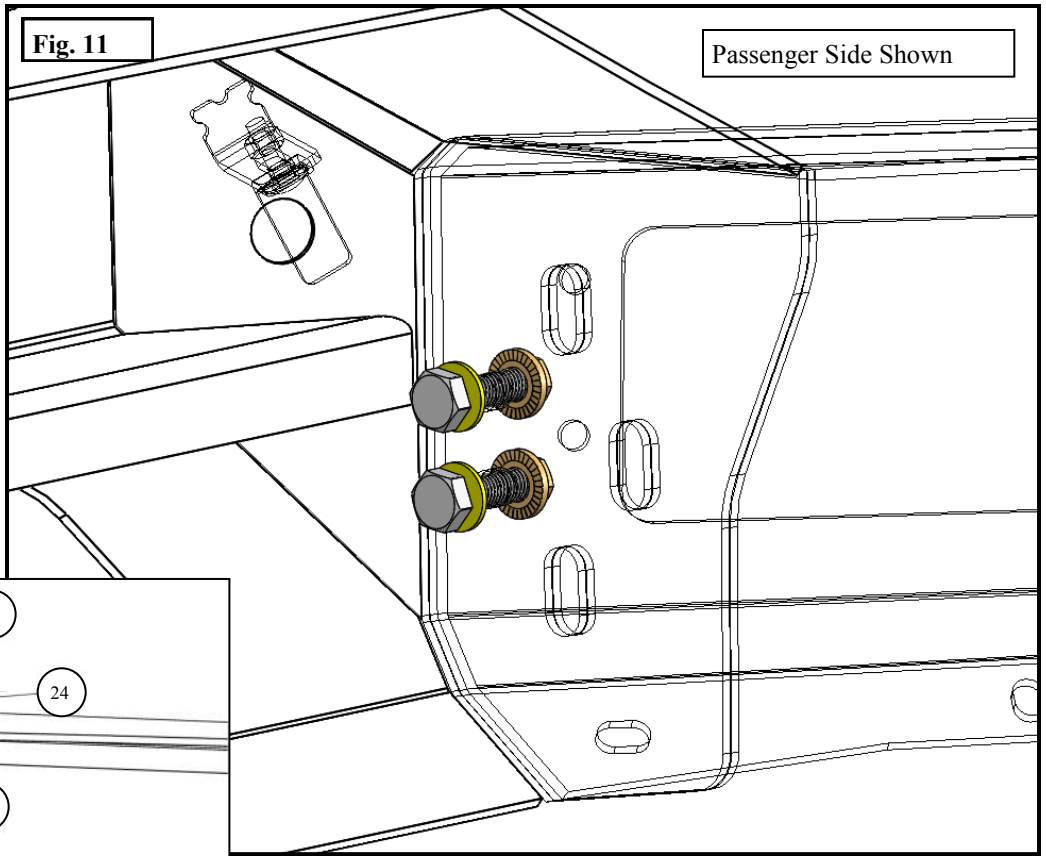

PARKING SENSOR INSTALLATION

***If not installing sensors, install Hole Plugs into holes on bumper and proceed**

15. Use the Sensor Tab (10) along with the supplied M6 Hardware (19-22) to install the sensors as shown in.

Figure 13.

16. Make sure to maintain OEM sensor orientation.

Note: Handle sensors with care as they are fragile.

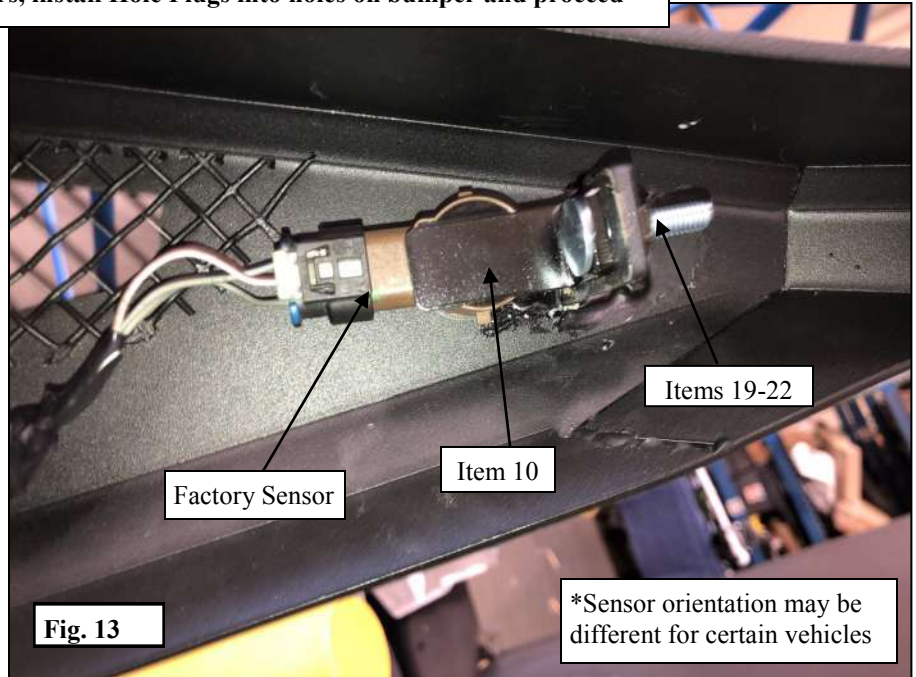

17. Using OEM hardware, fasten main brackets (Items 4-7) to frame of vehicle. **See Figure 14.**
18. Using M12 hardware items 13-15, fasten main brackets to inner brackets. **See Figure 14.**
19. Using M12 hardware items 13-15, fasten main brackets to preassembled bumper. **See Figure 15.**
19. Using M10 hardware items 16-18, fasten items 8 and 9 to main brackets. **See Figure 15.**
20. Using M8 hardware items 26-28, fasten items 8 and 9 to bumper sides **See Figure 15.**

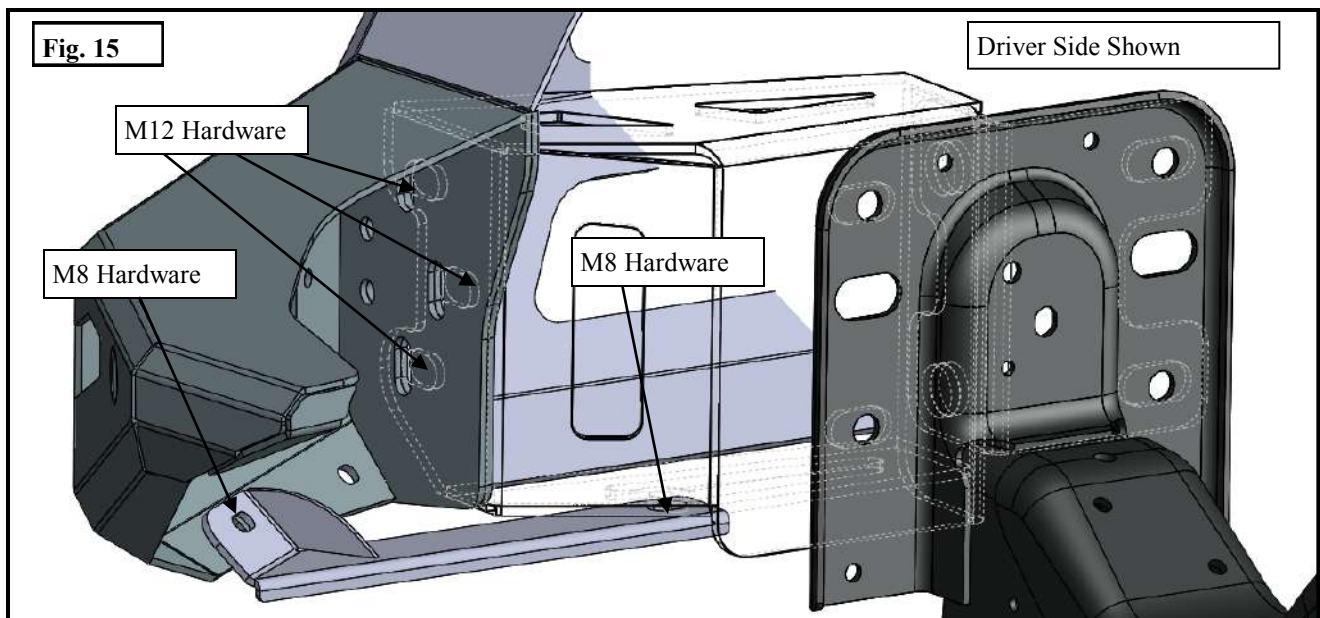
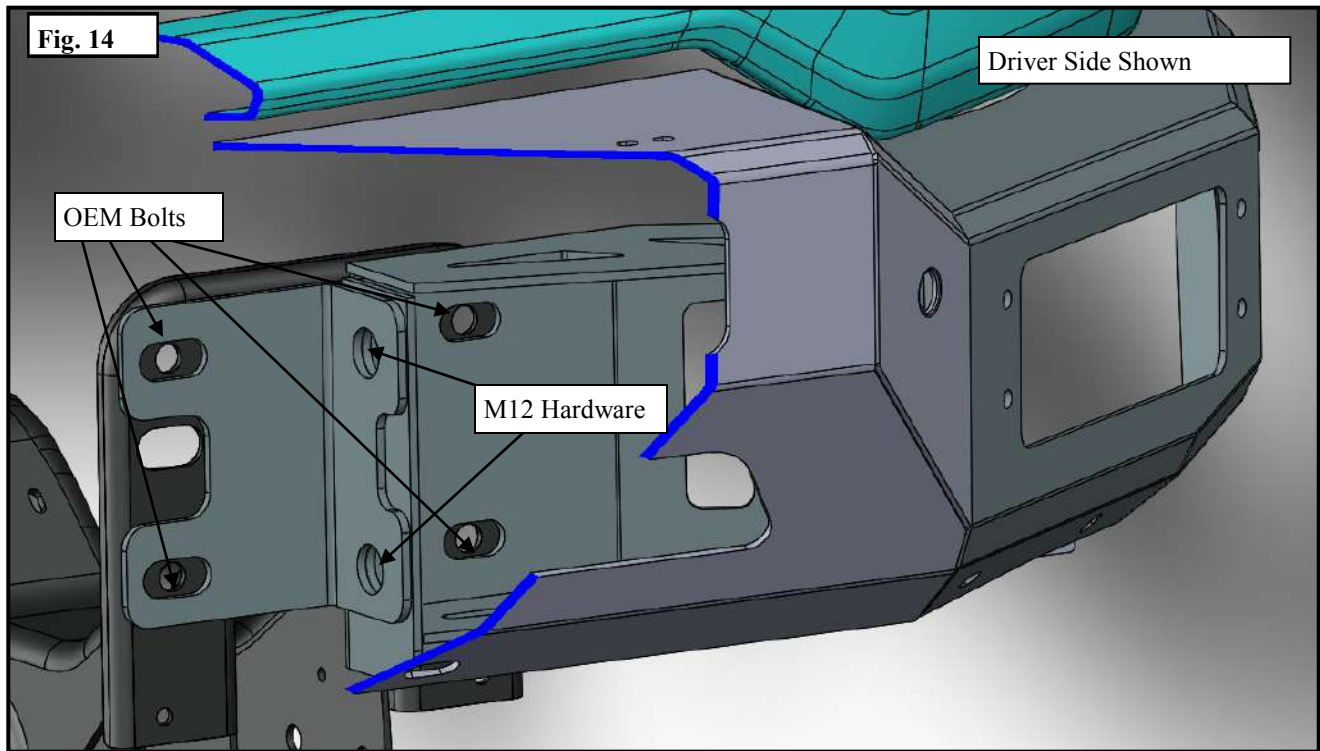

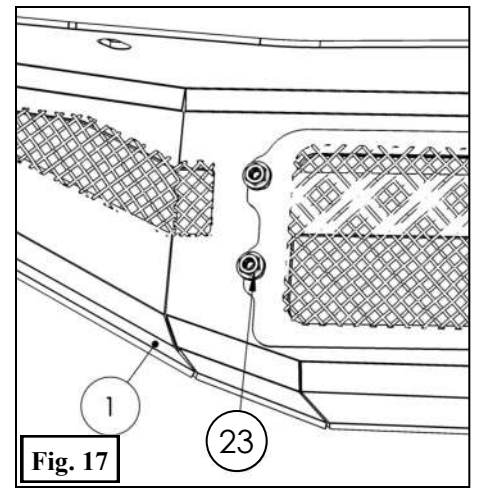
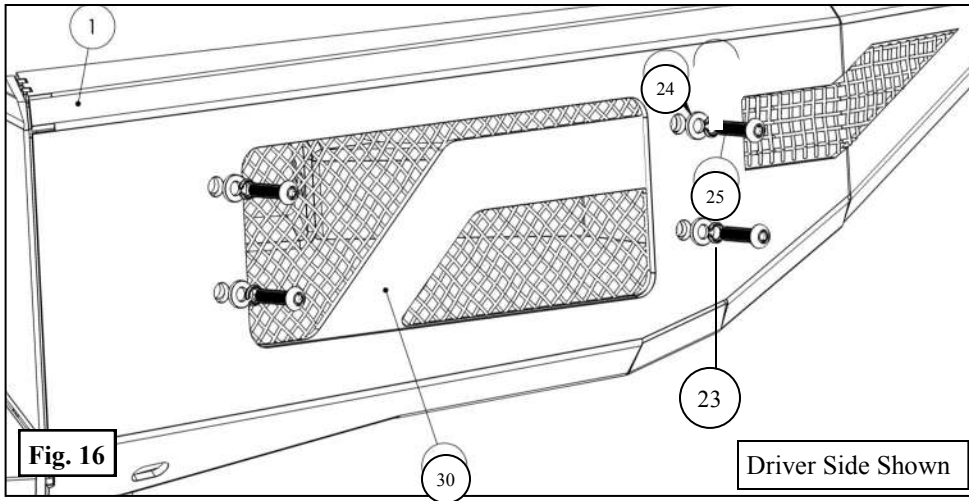

21. Adjust bumper as needed and torque down all hardware as specified: M6 to 7 ft lbs, M8 to 18 ft lbs, M10 to 38 ft lbs, and M12 to 60 ft lbs.

22. Trim inner fender lining as necessary.

23. Once the bumper is aligned and tight, remove the two center bolts fastening the main brackets to the frame. See **Figure 18**.

24. Using M6 hardware items 23-25, pre assemble active shutters with brackets **Items 31 and 32** as shown on **Figure 18,19**.

25. Using the hardware removed on step 23, fasten the assembly on to the main brackets as shown on **Figure 18,19** and torque M12 hardware to 60 ft lbs.

26. Connect the two cables from the active shutters.

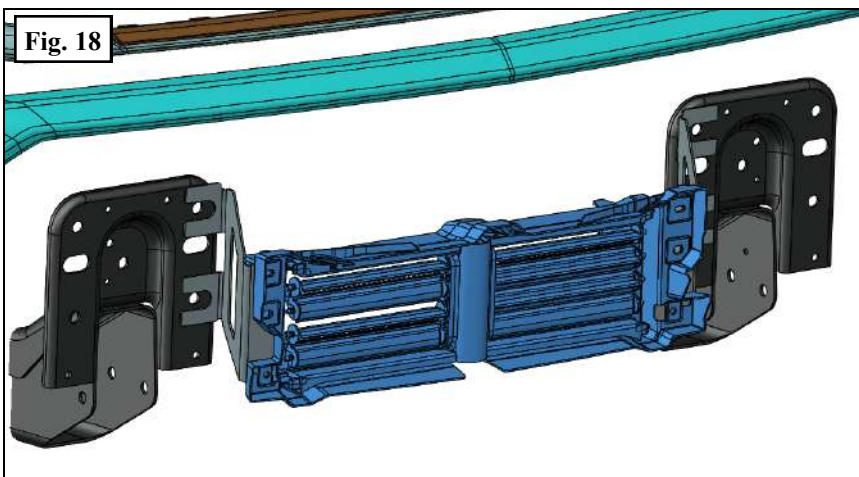

Installation Complete



©2018 WESTIN AUTOMOTIVE PRODUCTS, INC. ALL RIGHTS RESERVED

Skid plate and lights sold separately.

CARE INSTRUCTIONS

- REGULAR WAXING IS RECOMMENDED. DO NOT USE ANY TYPE OF POLISH OR WAX THAT MAY CONTAIN ABRASIVES.
- STAINLESS STEEL PRODUCTS CAN BE CLEANED WITH MILD SOAP AND WATER. STAINLESS STEEL POLISH SHOULD BE USED TO POLISH SMALL SCRATCHES.
- GLOSS BLACK FINISHES SHOULD BE CLEANED WITH MILD SOAP AND WATER.

WESTIN



WARNING



Failure to follow these instructions could lead to death, personal injury, and / or property damage.

Failure to follow these instructions could lead to death, personal injury, and / or property damage.

FASTENERS:

All Westin supplied fasteners must be utilized and installed in accordance with the installation instructions and apply torque to the specifications as defined. **DOUBLE CHECK ALL FASTENERS BEFORE INITIAL USE, AND PERIODICALLY IN THE FUTURE TO ENSURE PROPER FUNCTION AND SAFETY.**

DRILLING:

Most Westin products do not require drilling for installation. If drilling is defined as required, use caution when drilling a vehicle. **FAILURE TO REVIEW AN AREA TO BE DRILLED MAY RESULT IN PERSONAL INJURY AND/OR INJURY TO OTHERS AS WELL AS VEHICLE DAMAGE.**

EYE PROTECTION:

ALWAYS WEAR SAFETY GLASSES OR GOGGLES DURING THE INSTALLATION PROCESS TO AVOID PERSONAL INJURY.

MAXIMUM TOWING/CARRYING CAPACITY: (if applicable)

The Westin Receiver Hitches will have a visible tow rating label affixed directly on the product. User should never exceed the vehicle manufacturers maximum tow and weight rating regardless of the capacity of the hitch. **FAILURE TO FOLLOW THESE GUIDELINES WILL VOID THE WESTIN WARRANTY AND MAY RESULT IN PERSONAL INJURY AND/OR INJURY TO OTHERS AS WELL AS VEHICLE DAMAGE.**