

INSTALLATION INSTRUCTIONS

PRO-MOD FRONT BUMPER



APPLICATION:
2017-2019 Ford Raptor
PART NUMBER:
58-41145







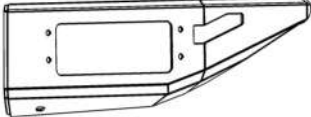
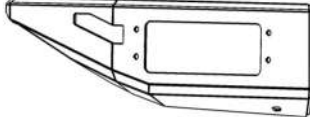
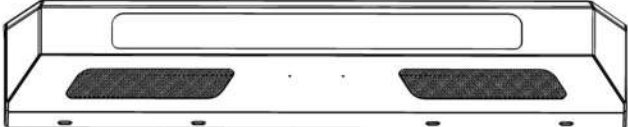
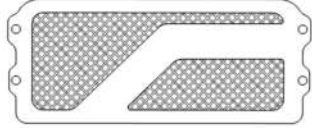

CONTENT			
ITEM	QUANTITY	DESCRIPTION	TOOLS NEEDED
1	1	DRIVER POD ASSEMBLY	10MM SOCKET
2	2	PASSENGER POD ASSEMBLY	10MM WRENCH
3	1	CENTER SECTION	13MM SOCKET
4	3	MESH SIDE COVERS	13MM WRENCH
5	1	SKID PLATE	16MM SOCKET
6	1	DRIVER MOUNTING BRACKET	16MM WRENCH
7	1	PASSENGER MOUNTING BRACKET	18MM SOCKET
8	1	DRIVER SUPPORT BRACKET	19MM WRENCH
9	1	PASSENGER SUPPORT BRACKET	ALLEN KEY
10	1	DRIVER SIDE STRAP	RATCHET
11	1	PASSENGER SIDE STRAP	TORQUE WRENCH
12	2	LED BRACKET	
13	12	M6 BUTTON HEAD BOLT	
14	12	M6 FLAT WASHER	
15	12	M6 SERRATED FLANGE NUT	
16	12	M6 LOCK WASHER	
17	18	SMALL M8 FLAT WASHER	
18	14	M8 SPLIT LOCK WASHER	
19	10	M8 SERRATED FLANGE NUT	
20	6	M12 SERRATED FLANGE NUT	
21	6	M12 HEX HEAD BOLT	
22	6	M12 LOCK WASHER	
23	12	M12 FLAT WASHER	
24	12	M8 BUTTON HEAD BOLT	
25	4	LARGE M8 FLAT WASHER	
26	2	M8 HEX HEAD BOLT	
27	6	M8 U-CLIP	
28	4	M10 HEX HEAD BOLT	

ANTI-SEIZE LUBRICANT MUST BE USED ON ALL STAINLESS STEEL FASTENERS TO PREVENT THREAD DAMAGE AND GALLING

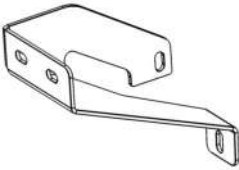
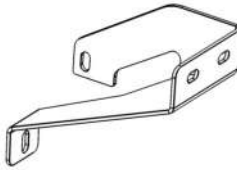

ITEM	QUANTITY	DESCRIPTION	TOOLS NEEDED
29	4	M10 SERRATED FLANGE NUT	
30	8	M10 FLAT WASHER	
31	4	M10 LOCK WASHER	

ANTI-SEIZE LUBRICANT MUST BE USED ON ALL STAINLESS STEEL FASTENERS TO PREVENT THREAD DAMAGE AND GALLING

			
ITEM 1	ITEM 2	ITEM 3	
			
ITEM 4	ITEM 5		
			
ITEM 6	ITEM 7	ITEM 8	ITEM 9
			
ITEM 10	ITEM 11	ITEM 12	

PROCEDURE

1. Remove contents from box, verify if all parts listed are present and free from damage. Carefully read and understand all instructions before attempting installation.
Failure to identify damage before installation could lead to a rejection of any claim.

2. Carefully remove the plastic cover from the front of the OEM Bumper. See **Figure 1**.
3. Remove the 3 bolts on either side securing the Adaptive Cruise Control (ACC) module to the vehicle. Unplug the module and remove it. See **Figure 2**.



4. Remove the bolt fastening the bumper support to the vehicle. See **Figure 3**.
5. Remove the 3 nuts securing the bumper to the vehicle and remove the bumper. See **Figure 4**. *Note: There are plastic clips that need to be removed from the top of the bumper that hold a rubber strip. Do this while removing the bumper.*

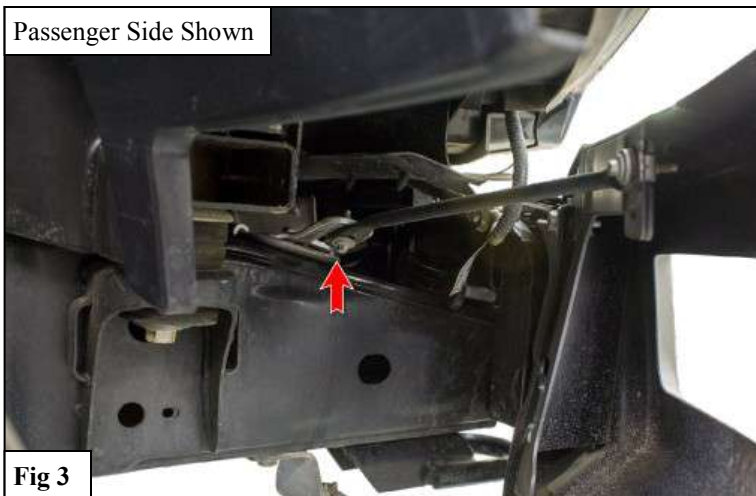

6. Use the supplied M10 Hardware to attach each Side Pod Assembly (1,2) to the Center Section (3). See **Figure 5**.
7. Use the supplied M6 Hardware to attach the LED Brackets (12) to the center section. See **Figure 6**. *Note: If installing an LED Light Bar (sold separately), install it at this time.*

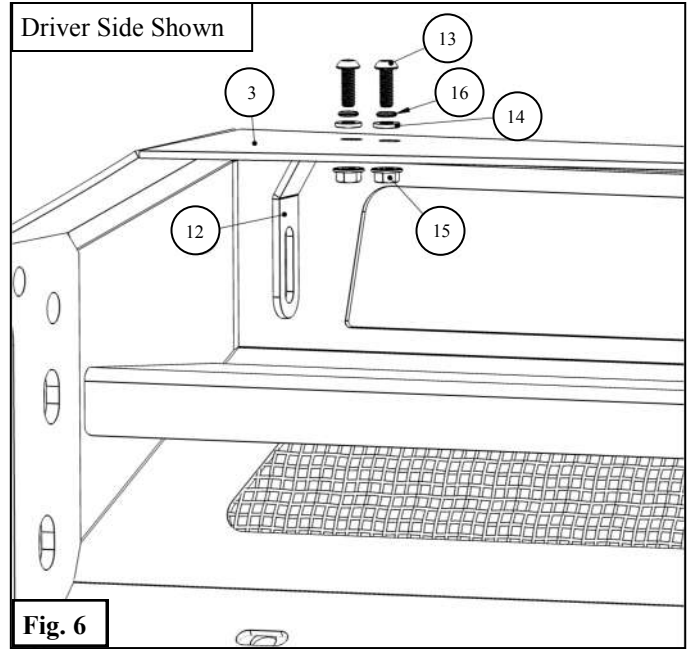
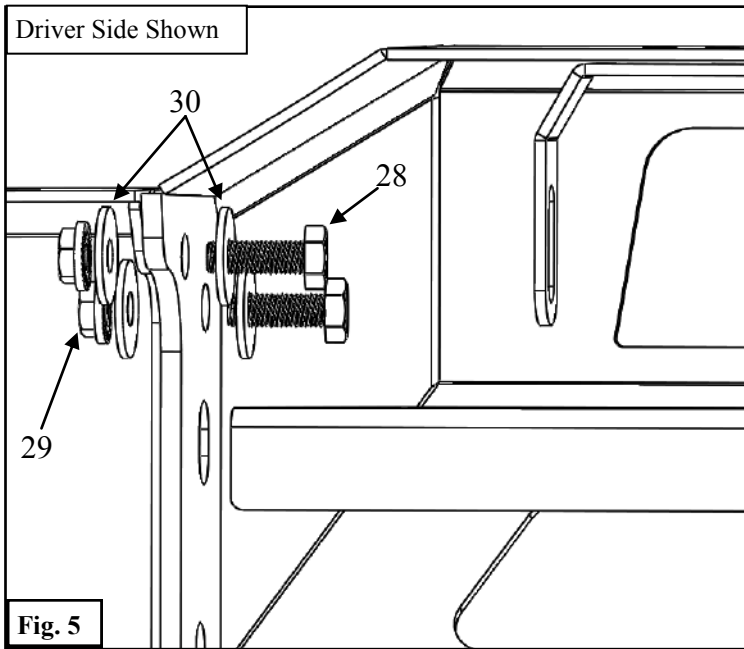

8. Use the supplied M12 Hardware to attach the Mounting Brackets (6,7) to the pre-assembled bumper. See **Figures 7 & 8**.

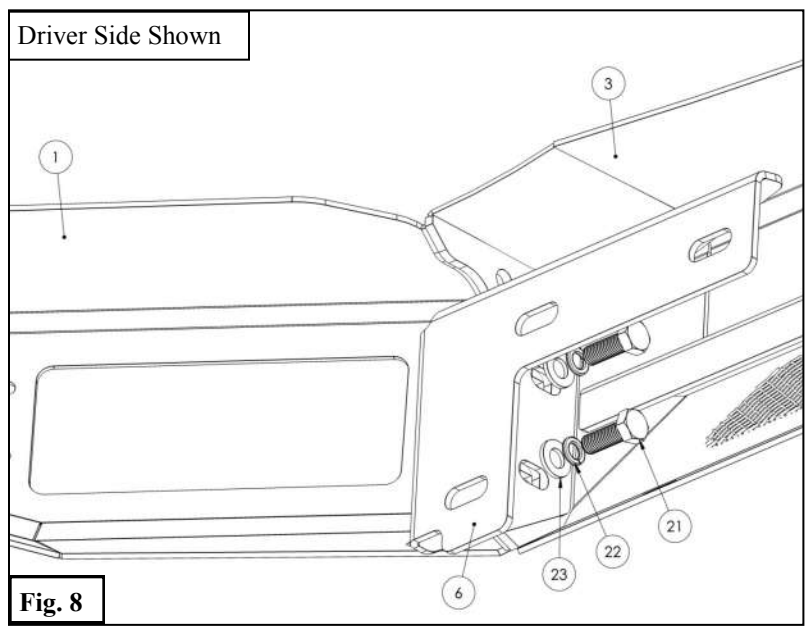
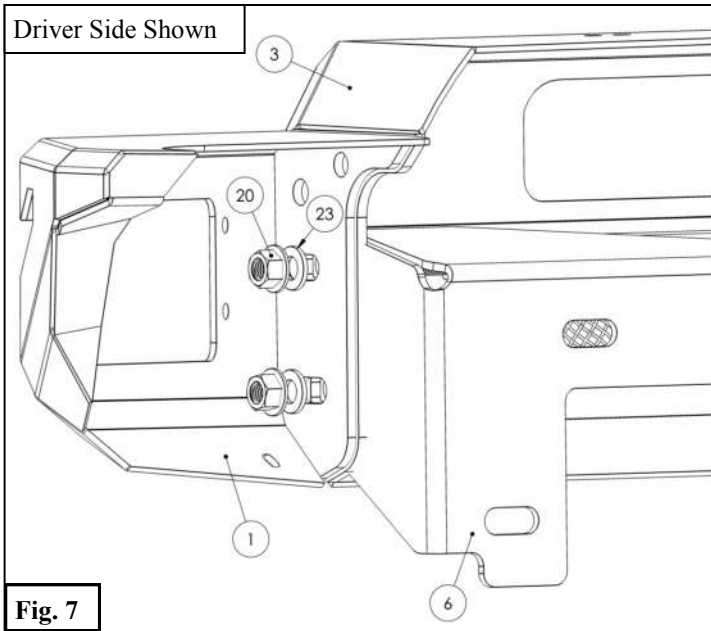

9. Use the OEM Hardware and supplied M12 Hardware to attach the pre-assembled bumper and mounting brackets to the vehicle. See **Figure 9**.

10. Use the supplied M8 Hardware to loosely attach the Support Brackets (8,9) to the vehicle. See **Figure 10**.

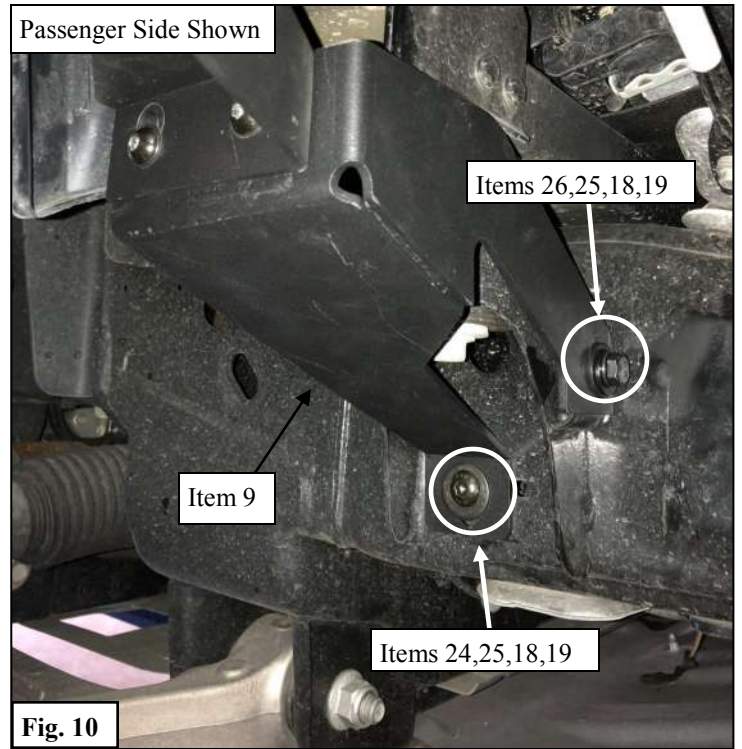
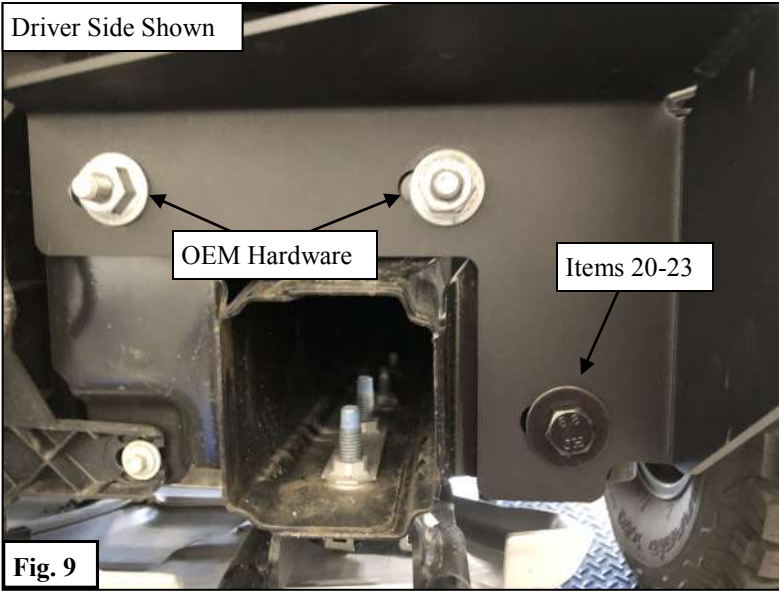

11. Use the supplied M8 Hardware to attach the Side Straps (10,11) to the Support Brackets (8,9). See **Figure 11**.

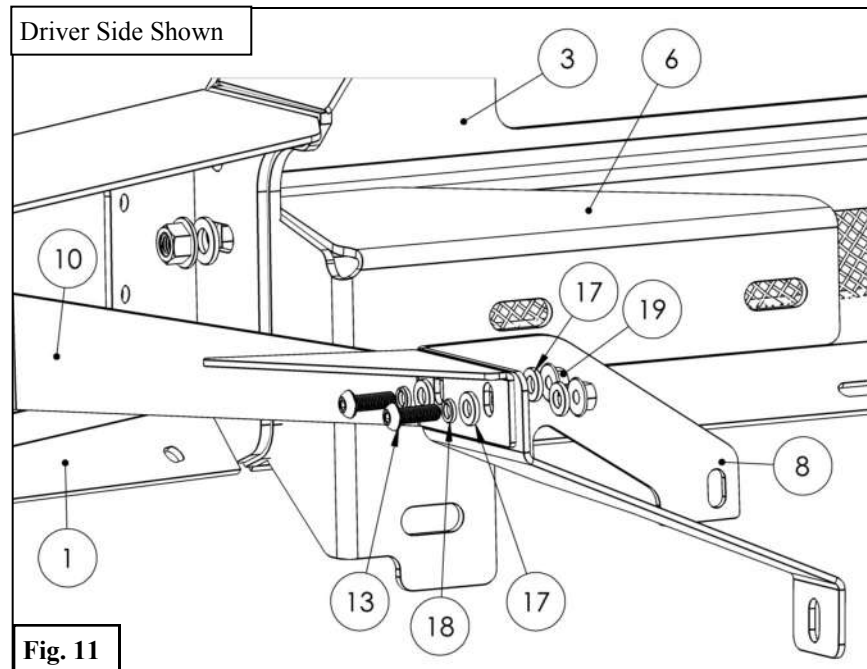

12. Attach the Mesh Side Covers (4) to the Bumper and Side Straps (10,11) using the supplied M6 Hardware. See **Figures 12 & 13.**

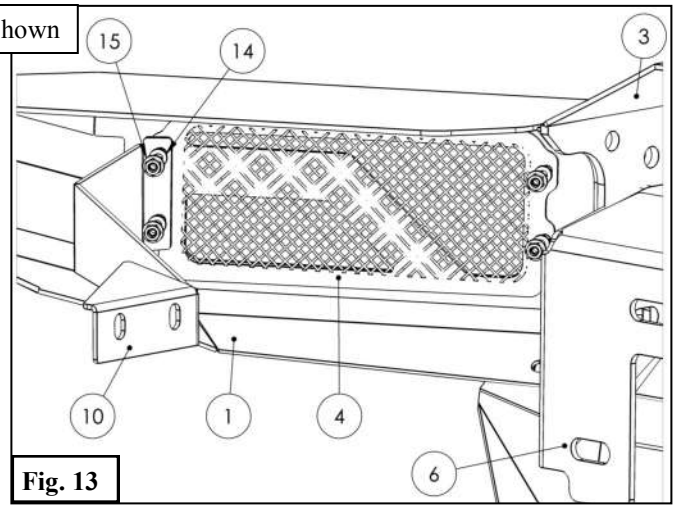
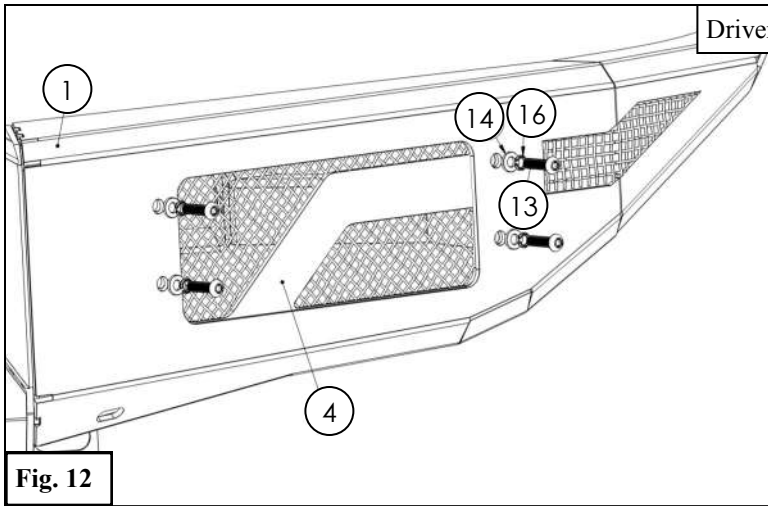

13. Attach the supplied M8 U-Clips (27) to the Bumper along the bottom edge as shown in **Figure 14**.
14. Attach the Skid Plate (4) to the U-Clips (27) using the supplied M8 Hardware. See **Figure 15**.
15. Align bumper as desired and torque all hardware as specified: M6 to 7 ft-lbs, M8 to 18 ft-lbs, M10 to 38 ft-lbs, M12 to 60 ft-lbs.

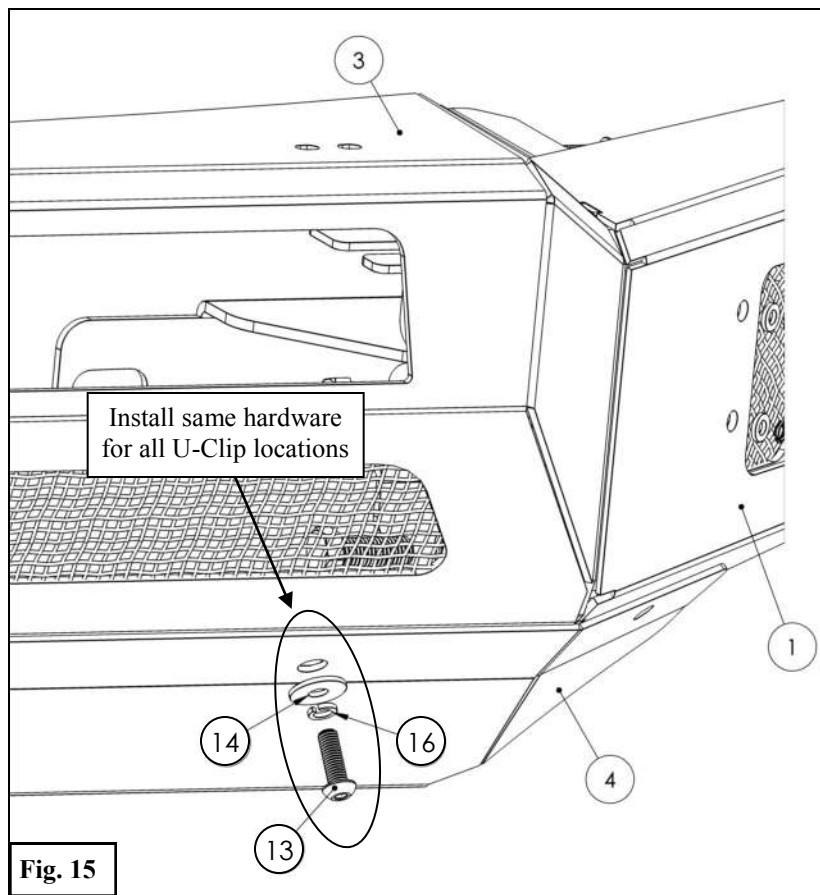
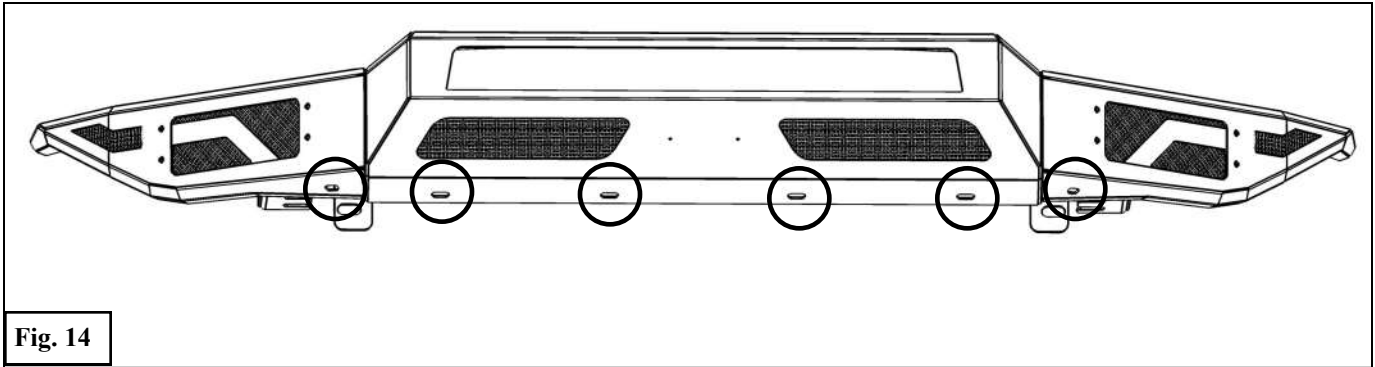

INSTALLATION COMPLETE



LED Lights Sold Separately

CARE INSTRUCTIONS

- REGULAR WAXING IS RECOMMENDED. DO NOT USE ANY TYPE OF POLISH OR WAX THAT MAY CONTAIN ABRASIVES.
- STAINLESS STEEL PRODUCTS CAN BE CLEANED WITH MILD SOAP AND WATER. STAINLESS STEEL POLISH SHOULD BE USED TO POLISH SMALL SCRATCHES.
- GLOSS BLACK FINISHES SHOULD BE CLEANED WITH MILD SOAP AND WATER

WESTIN



WARNING



Failure to follow these instructions could lead to death, personal injury, and / or property damage.

Failure to follow these instructions could lead to death, personal injury, and / or property damage.

FASTENERS:

All Westin supplied fasteners must be utilized and installed in accordance with the installation instructions and apply torque to the specifications as defined. **DOUBLE CHECK ALL FASTENERS BEFORE INITIAL USE, AND PERIODICALLY IN THE FUTURE TO ENSURE PROPER FUNCTION AND SAFETY.**

DRILLING:

Most Westin products do not require drilling for installation. If drilling is defined as required, use caution when drilling a vehicle. **FAILURE TO REVIEW AN AREA TO BE DRILLED MAY RESULT IN PERSONAL INJURY AND/OR INJURY TO OTHERS AS WELL AS VEHICLE DAMAGE.**

EYE PROTECTION:

ALWAYS WEAR SAFETY GLASSES OR GOGGLES DURING THE INSTALLATION PROCESS TO AVOID PERSONAL INJURY.

MAXIMUM TOWING/CARRYING CAPACITY: (if applicable)

The Westin Receiver Hitches will have a visible tow rating label affixed directly on the product. User should never exceed the vehicle manufacturers maximum tow and weight rating regardless of the capacity of the hitch. **FAILURE TO FOLLOW THESE GUIDELINES WILL VOID THE WESTIN WARRANTY AND MAY RESULT IN PERSONAL INJURY AND/OR INJURY TO OTHERS AS WELL AS VEHICLE DAMAGE.**

FOR CALIFORNIA RESIDENTS ONLY-PROP 65 WARNING:

Some products may contain chemicals such as DEHP, which can cause cancer, birth defects or other reproductive harm.

