

INSTALLATION INSTRUCTIONS



HDX WINCH MOUNT GRILLE GUARD/MAX WINCH TRAY

APPLICATION:

2019 Chevrolet Silverado 1500 (Excl. 2019 Silverado LD)

PART NUMBER:

46-23955, 57-93950, 57-93955

ITEM	QUANTITY	DESCRIPTION	TOOLS NEEDED
1	1	WINCH TRAY	15MM SOCKET
2,3	2	WINCH TRAY MOUNTING BRACKETS, DRIVER (2) AND PASSENGER (3)	18MM SOCKET
4	2	SPACER BRACKET (ONLY USED WITH WINCH TRAY GRILLE GUARD KITS)	15MM WRENCH
5	2	M12 BOLT PLATE	18MM WRENCH
6	2	M10 BOLT PLATE	SCREW DRIVER
7	2	LARGE SPACER WASHER	UTILITY KNIFE
8	4	M12 HEX HEAD CAP SCREW (BLACK ZINC)	RATCHET
9	4	SMALL M12 FLAT WASHER (BLACK ZINC)	TORQUE WRENCH
10	4	LARGE M12 FLAT WASHER (BLACK ZINC)	
11	6	M12 SPLIT LOCK WASHER (BLACK ZINC)	
12	6	M12 HEX NUT (BLACK ZINC)	
13	2	M10 HEX HEAD CAP SCREW (BLACK ZINC)	
14	4	M10 FLAT WASHER (BLACK ZINC)	
15	4	M10 SPLIT LOCK WASHER (BLACK ZINC)	
16	2	M10 HEX NUT (BLACK ZINC)	
17	2	M10 SERRATED FLANGE BOLT (BLACK ZINC)	
18	2	M10 SERRATED FLANGE NUT (BLACK ZINC)	
19	4	M12 BUTTON HEAD BOLT (BLACK ZINC)	
20	4	M12 BELLVILLE WASHER (BLACK ZINC)	
21	4	M12 SERRATED FLANGE NUT (BLACK ZINC)	
22	2	M10 FISH WIRE	
23	2	M12 FISH WIRE	
24	2	M10 PLASTIC RETAINER SQUARE	
25	2	M12 PLASTIC RETAINER SQUARE	
26	1	GRILLE GUARD ASSEMBLY	PARTS COME WITH WINCH MOUNT GRILLE GUARD KITS ONLY (ITEMS 26-35)
27,28	2	TOP SUPPORT STRAP, DRIVER (27) AND PASSENGER (28)	
29	4	M12 HEX HEAD FLANGE BOLT (BLACK ZINC)	
30	8	M12 HEX HEAD SERRATED FLANGE NUT (BLACK ZINC)	
31	2	M10 HEX SOCKET BUTTON HEAD SCREW (RAW OR BLACK ZINC)	ITEMS 31-35 ARE STAINLESS STEEL
32	2	M10 BELLVILLE WASHER (RAW OR BLACK ZINC)	
33	2	M10 SERRATED FLANGE NUT (RAW OR BLACK ZINC)	
34	4	M12 BELLVILLE WASHER (RAW OR BLACK ZINC)	
35	4	M12 HEX SOCKET BUTTON HEAD SCREW (RAW OR BLACK ZINC)	

ANTI-SEIZE LUBRICANT MUST BE USED ON ALL STAINLESS STEEL FASTENERS TO PREVENT THREAD DAMAGE AND GALLING



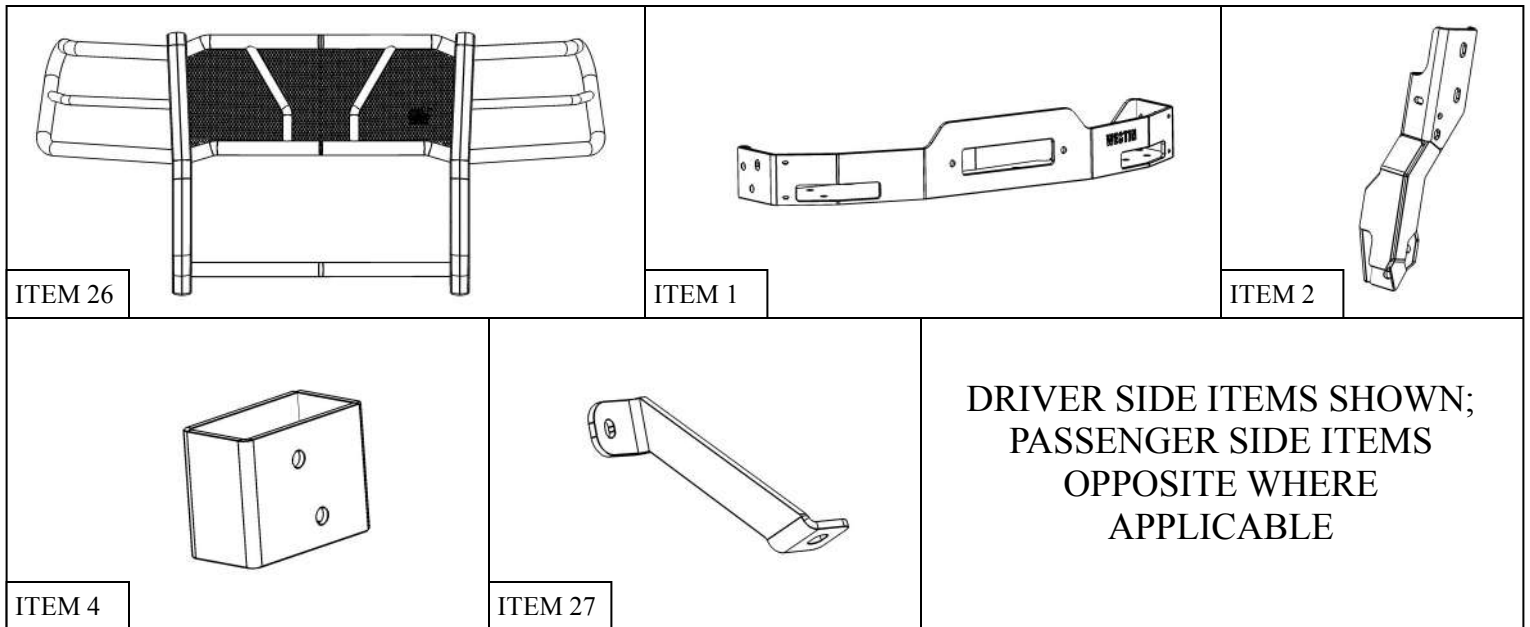

PROCEDURE

1. Remove contents from box, verify if all parts listed are present and free from damage.
Carefully read and understand all instructions before attempting installation.
Failure to identify damage before installation could lead to a rejection of any claim.
2. Begin by removing the plastic trim fasteners holding the grille in place. Also dethatch the clips of the wings of the grille. See **Figures 1 & 2.**
3. Remove the grille by pulling firmly and carefully at the bottom of the grille.

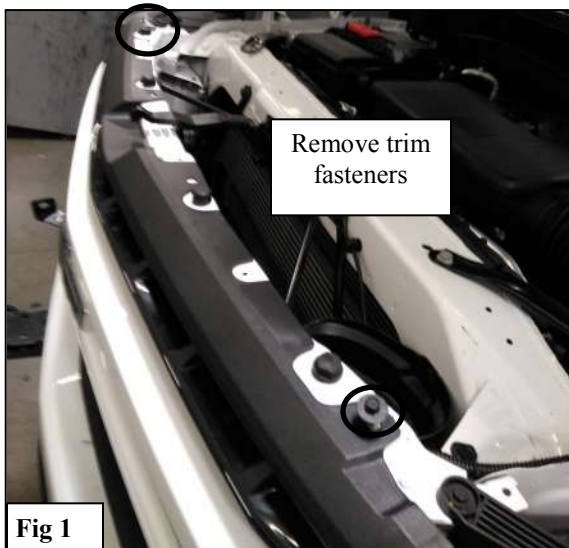

4. Remove the 4 bolts behind the plastic cover securing the bumper to the vehicle. See **Figure 3**.
5. Also remove the bolts on the bottom of the frame securing the bumper supports to the vehicle. See **Figure 4**.

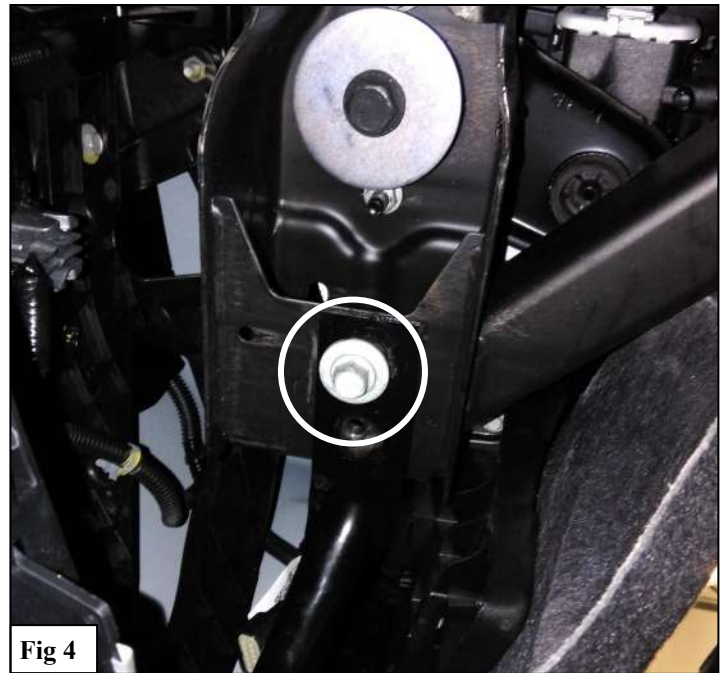

6. Unplug any wire harnesses running to the front bumper (fog lights, sensors, etc...).
7. Use the OEM hardware to secure the Top Support Straps (27-28) to the bumper. *Note: Bumper shown off vehicle for viewing purposes.* See **Figure 5**. **THIS STEP ONLY TAKEN FOR GRILLE GUARD INSTALL.**
8. Trim the factory trim area to fit the Winch Tray Mounting Bracket (2-3). See **Figure 6**.

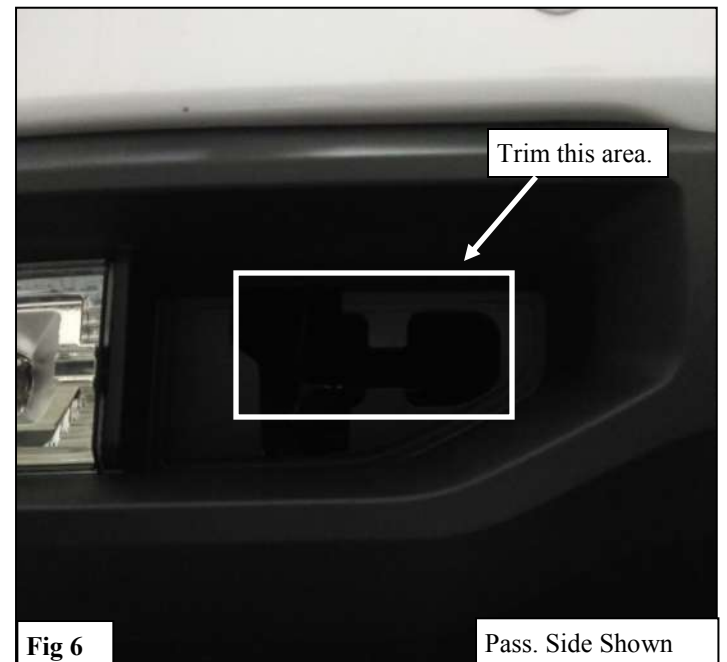
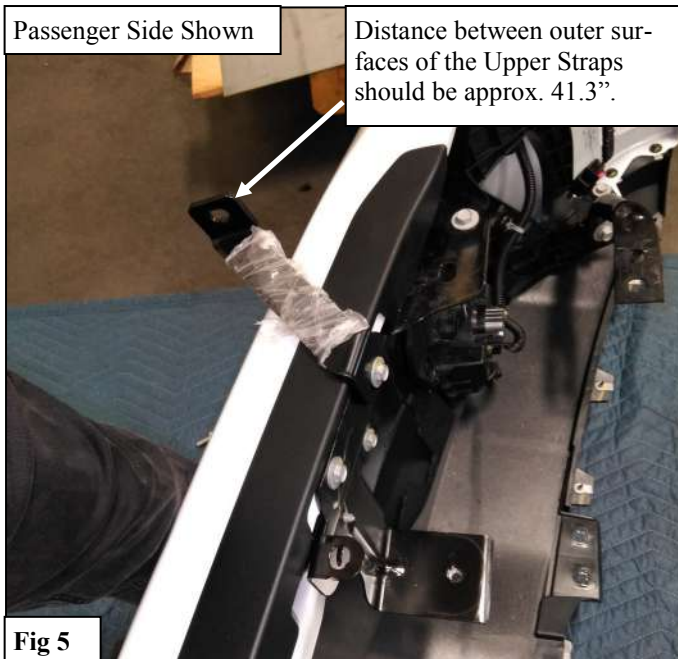

9. Insert the Winch Tray Mounting Bracket (2-3) into the frame. Use the supplied M10 & M12 Fish Wires to insert the M10 and M12 Bolt Plates into their positions. See **Figure 7**. *Note: The Plastic Retainer Squares (24-25) may be used to hold the bolt plates in place.*
10. Use the supplied Large Spacer Washer (7) along with the supplied M10 and M12 Hardware to finish installing the Winch Tray Mounting Brackets (2-3). See **Figures 8 & 9**. *Note: Leave hardware loose until end of install.*

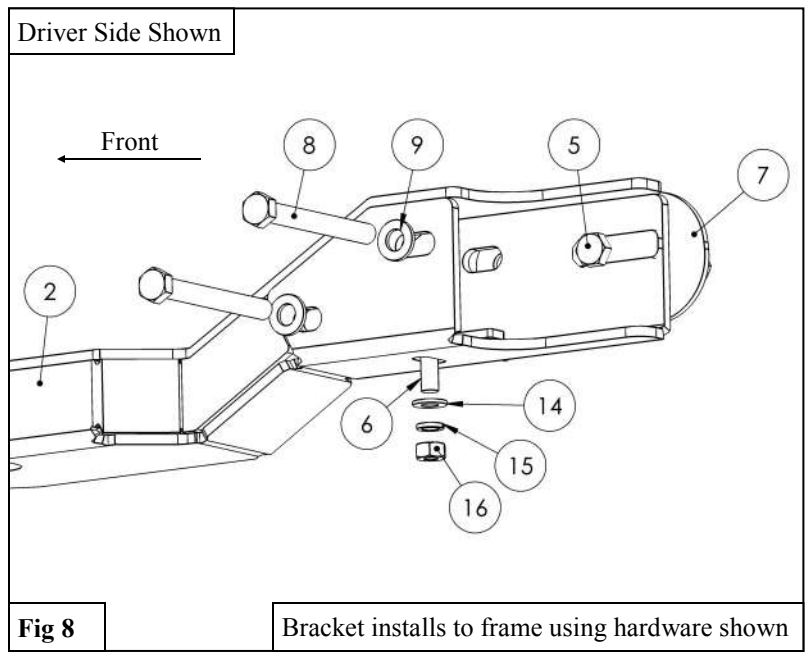
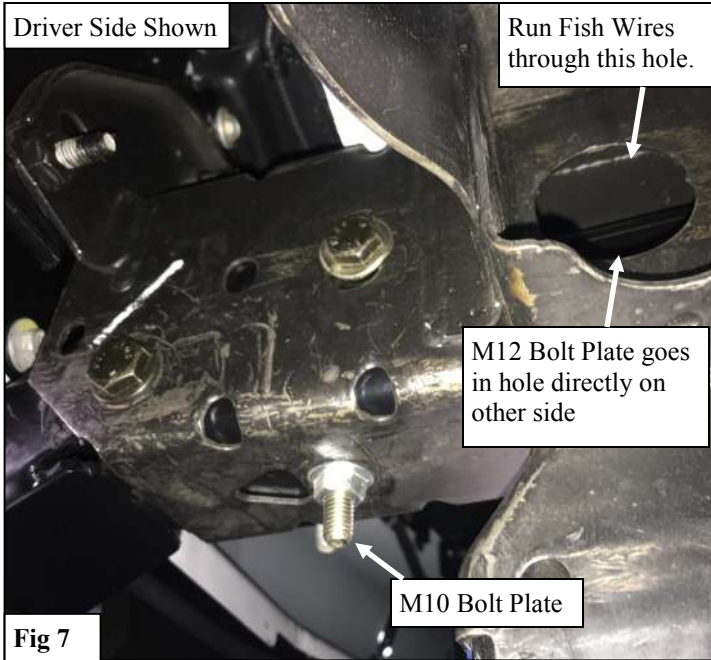

11. Loosely install the Winch Tray to the mounting brackets using the supplied M10 hardware (Items 17 and 18) and the supplied M12 hardware (Items 19-21) See **Figure 10**.

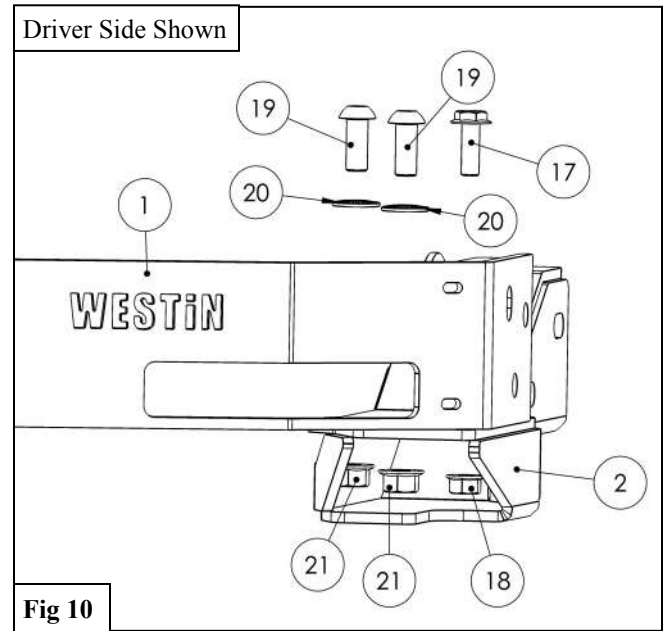
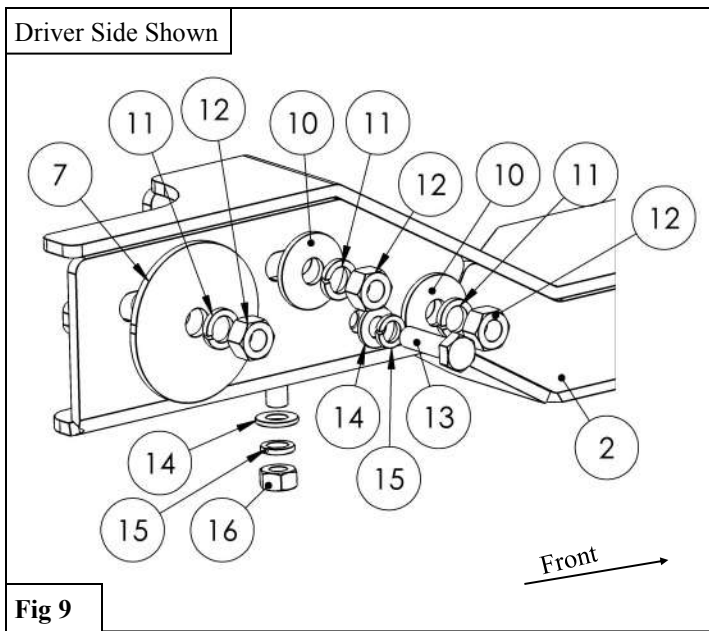

WINCH TRAY INSTALLATION COMPLETE

GRILLE GUARD INSTALLATION

12. Locate and attach both Spacer Brackets (Item 4) to the Winch Tray using (4) M12 hex head flange bolt and (4) M12 hex head serrated flange nut. See **Figure 11**.
13. Install Winch per Winch Manufacturer's Instructions. **Note:** It may be very difficult to install the winch after the Grille Guard has been installed.
14. With assistance loosely install the Grille Guard Assembly (Item 26) onto the previously installed spacer brackets. Loosely bolt the Grille Guard to the Top Support Straps (Items 27-28) using the supplied M12 hardware. See **Figures 12 & 13**.
15. Align and adjust the Grille Guard Assembly as necessary. Tighten all remaining hardware: M10 to 30-35 ft-lbs and M12 to 50-55 ft-lbs.

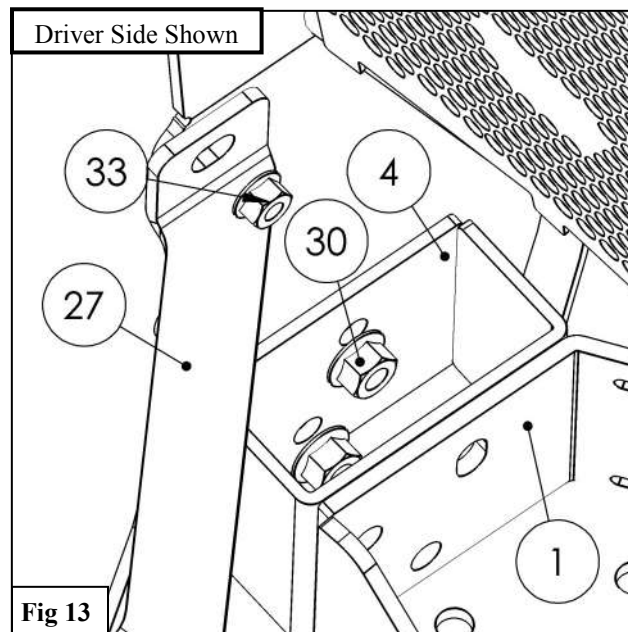
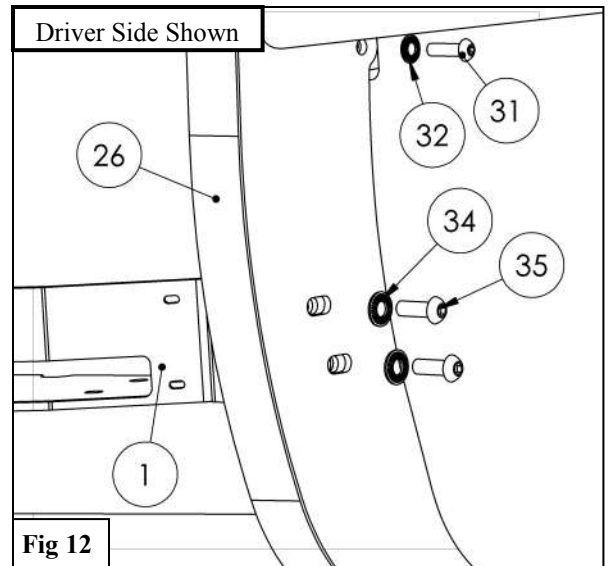
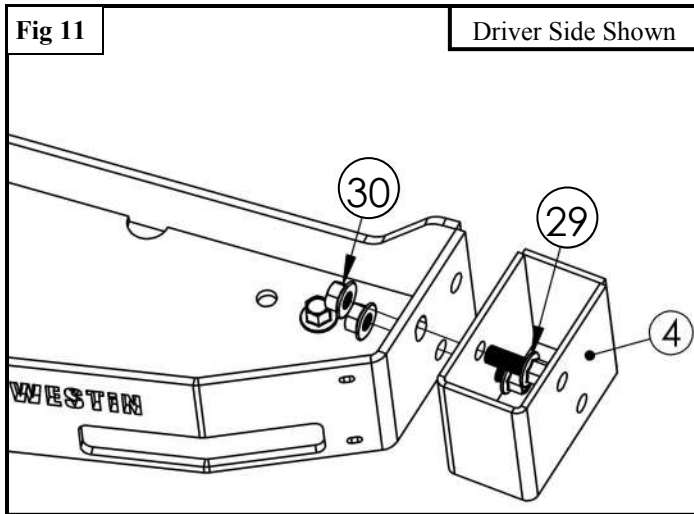

CARE INSTRUCTIONS

- REGULAR WAXING IS RECOMMENDED. DO NOT USE ANY TYPE OF POLISH OR WAX THAT MAY CONTAIN ABRASIVES.
- STAINLESS STEEL PRODUCTS CAN BE CLEANED WITH MILD SOAP AND WATER. STAINLESS STEEL POLISH SHOULD BE USED TO POLISH SMALL SCRATCHES.
- GLOSS BLACK FINISHES SHOULD BE CLEANED WITH MILD SOAP AND WATER.

WESTIN

INSTALLATION COMPLETE



Winch Sold Separately

WESTiN



WARNING



Failure to follow these instructions could lead to death, personal injury, and / or property damage.

Failure to follow these instructions could lead to death, personal injury, and / or property damage.

FASTENERS:

All Westin supplied fasteners must be utilized and installed in accordance with the installation instructions and apply torque to the specifications as defined. **DOUBLE CHECK ALL FASTENERS BEFORE INITIAL USE, AND PERIODICALLY IN THE FUTURE TO ENSURE PROPER FUNCTION AND SAFETY.**

DRILLING:

Most Westin products do not require drilling for installation. If drilling is defined as required, use caution when drilling a vehicle. **FAILURE TO REVIEW AN AREA TO BE DRILLED MAY RESULT IN PERSONAL INJURY AND/OR INJURY TO OTHERS AS WELL AS VEHICLE DAMAGE.**

EYE PROTECTION:

ALWAYS WEAR SAFETY GLASSES OR GOGGLES DURING THE INSTALLATION PROCESS TO AVOID PERSONAL INJURY.

MAXIMUM TOWING/CARRYING CAPACITY: (if applicable)

The Westin Receiver Hitches will have a visible tow rating label affixed directly on the product. User should never exceed the vehicle manufacturers maximum tow and weight rating regardless of the capacity of the hitch. **FAILURE TO FOLLOW THESE GUIDELINES WILL VOID THE WESTIN WARRANTY AND MAY RESULT IN PERSONAL INJURY AND/OR INJURY TO OTHERS AS WELL AS VEHICLE DAMAGE.**