



AUTOMOTIVE PRODUCTS,

INSTALLATION INSTRUCTIONS

HDX DROP STEP

APPLICATION:

2017 Ford F250/350 - SuperCrew 6 Ft Bed

PART NUMBER:

56-534025, 56-5340252

CONTENT			
ITEM	QUANTITY	DESCRIPTION	TOOLS NEEDED
1	2	STEP BAR ASSEMBLY	3/8" DRIVE RATCHET
2	2	FRONT MOUNTING BRACKET	1/2" DRIVE RATCHET
3	2	CENTER MOUNTING BRACKET	TORQUE WRENCH
4	2	REAR MOUNTING BRACKET	13MM SOCKET
5,6	2	TOP ISOLATOR MOUNTING BRACKET DRIVER (5), PASSENGER (6)	SOCKET EXT.
7	6	UNIVERSAL BRACKET	13MM WRENCH
8	48	M8 SPLIT LOCK WASHER (YELLOW ZINC)	18MM SOCKET
9	48	M8 LARGE FLAT WASHER (YELLOW ZINC)	19MM SOCKET
10	24	M8 HEX NUT (YELLOW ZINC)	18MM WRENCH
11	6	M8 ROUND HEAD SQUARE NECK BOLT (BLACK ZINC)	19MM WRENCH
12	22	M8 PLASTIC RETAINER	15MM WRENCH
13	4	M8 HEX HEAD BOLT SHORT (YELLOW ZINC)	15MM SOCKET
14	20	M8 HEX HEAD BOLT LONG (YELLOW ZINC)	16MM WRENCH
15	4	M8 NUT CLIP (ZINC PLATED)	16MM SOCKET
16	4	M10 HEX NUT (YELLOW ZINC)	
17	4	M10 SPLIT LOCK WASHER (YELLOW ZINC)	
18	4	M10 FLAT WASHER (YELLOW ZINC)	
19	2	M12 HEX HEAD BOLT (YELLOW ZINC)	
20	2	M12 SPLIT LOCK WASHER (YELLOW ZINC)	
21,22	2	BOTTOM ISOLATOR MOUNTING BRACKET DRIVER (21), PASSENGER (22)	
23,24	2	DRIVER SIDE MOUNTING BRACKET A (23), PASSENGER (24)	
25	2	M10 DOUBLE BOLT PLATE	
26	2	ISOLATOR KIT	
27	4	M10 PLASTIC RETAINER	

ANTI-SEIZE LUBRICANT MUST BE USED ON ALL STAINLESS STEEL FASTENERS TO PREVENT THREAD DAMAGE AND GALLING

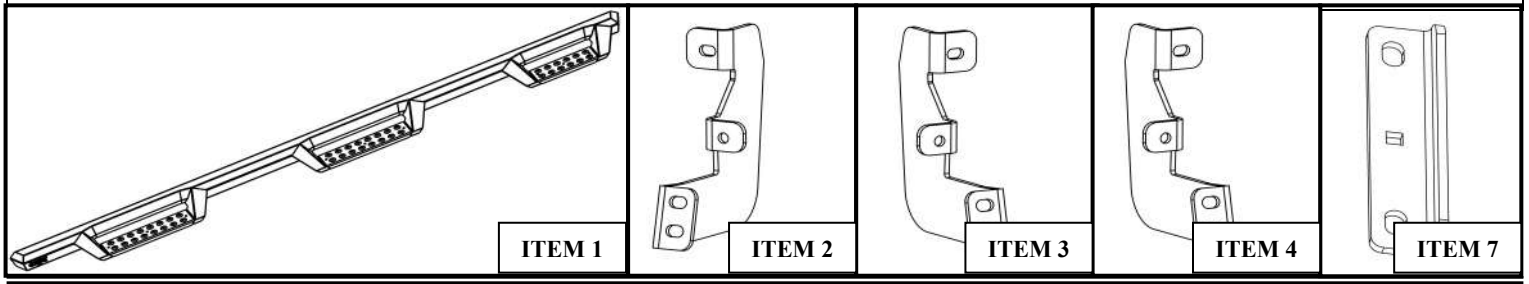

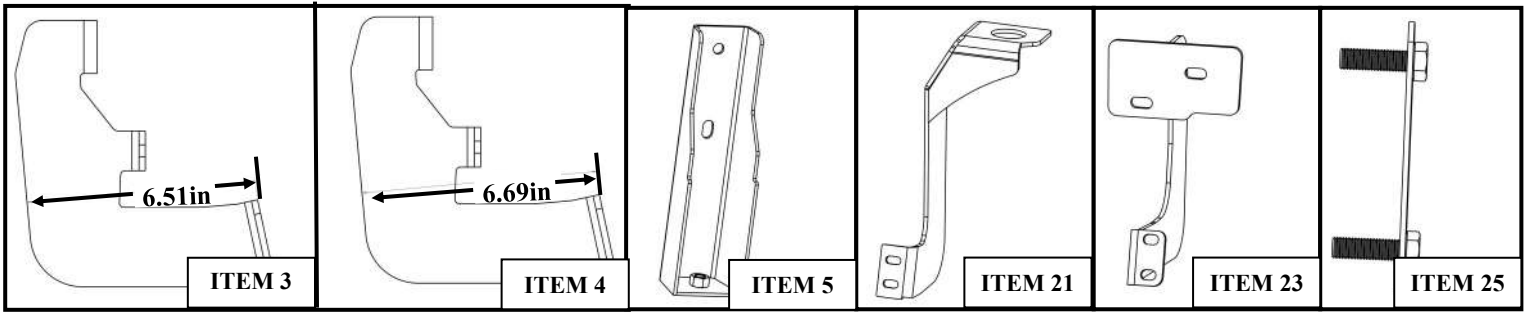

PROCEDURE

1. Remove contents from box, verify if all parts listed are present and free from damage. Carefully read and understand all instructions before attempting installation.
Failure to identify damage before installation could lead to a rejection of any claim.

2. Start installation on driver's side. On the rocker panel find locations of factory studs. In each location there should be 3 studs. See **Figure 1**.
3. Insert (1) M8 Plastic Retainer (Item 12) on each factory stud. See **Figure 2**.

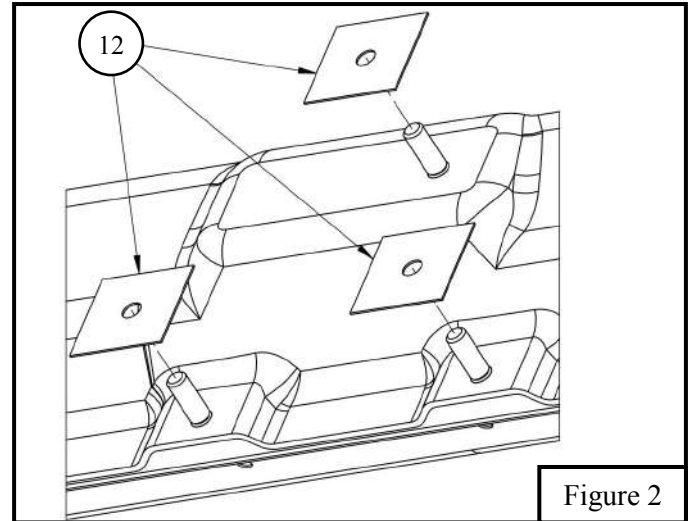
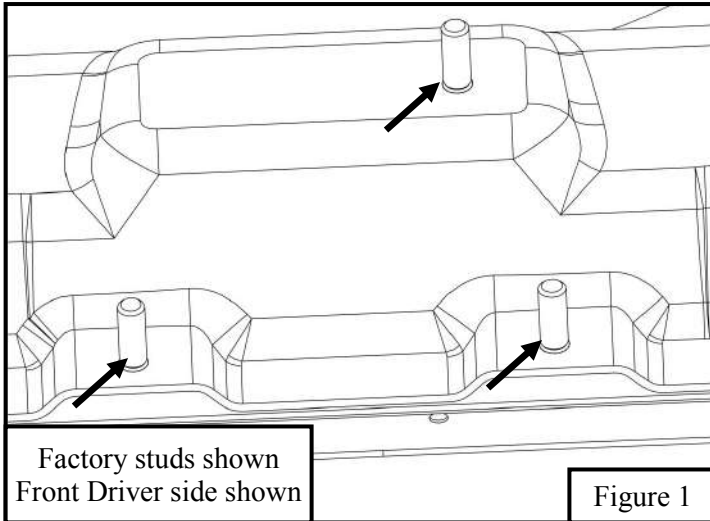

4. Insert the M8 round head square neck bolt (Item 11) through the Universal Mounting Bracket's (Item 7) square hole. Then insert the M8 round head square neck bolt through mounting brackets (Item 2 - 6) bottom circular hole. Loosely secure with (1) M8 hex nut, (1) M8 split lock washer, and (1) M8 flat washer. See **Figure 3**.
5. Align sub-assembly with the 3 factory studs. Lower 2 factory studs will align with the Universal Mounting Bracket and top factory stud will align with mounting brackets. Loosely secure sub-assembly with (3) M8 hex nut, (3) M8 split lock washer, and (3) M8 flat washer. See **Figure 4**.
6. Repeat **Step 3-4** for front, center, and rear mounting locations on both passenger and driver side.

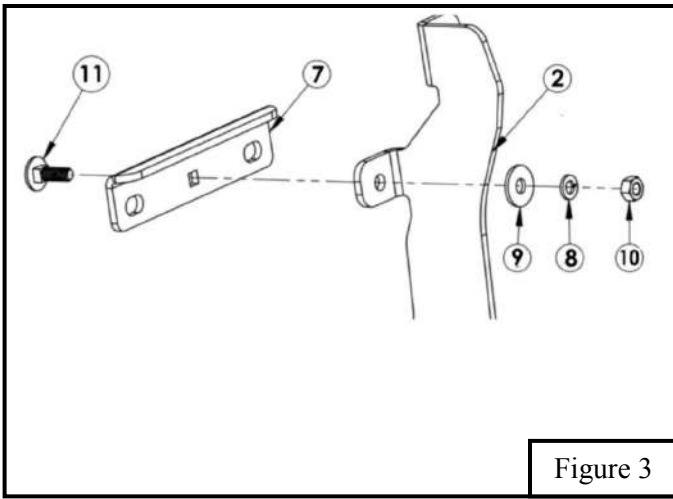
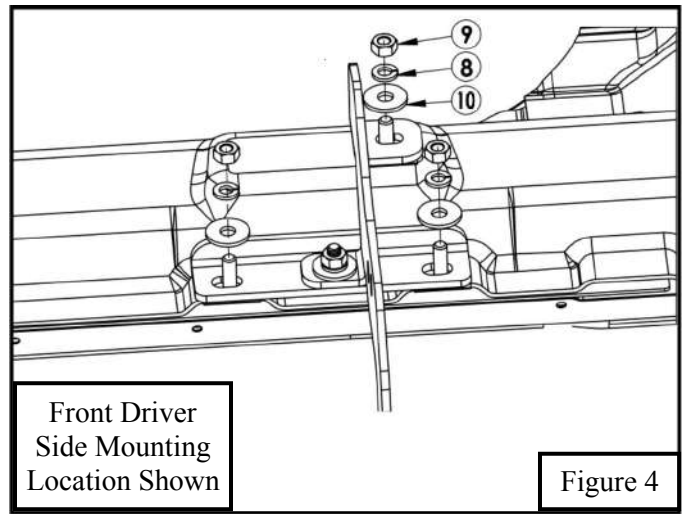

Figure 3



Front Driver Side Mounting Location Shown

Figure 4

7. Locate the two mounting locations at the rear of the cab of truck. There will be holes to insert the supplied nut clips (item 15). Locate Mounting Bracket A (Item 23) and install loosely with supplied M8 hardware. See **Figure 5**
8. Locate Top Isolator mounting area underneath the bed at the front of the rear wheel well. There will be a portion of the bed with 2 large holes where (item 25) will be mounted. Locate Top Isolator Bracket (Item 5) and loosely install with the supplied M10 bolt plate and hardware. See **Figure 6 & 7**

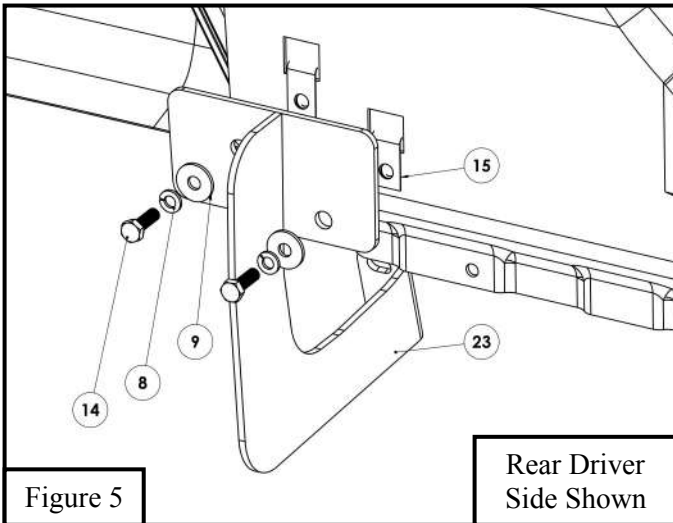
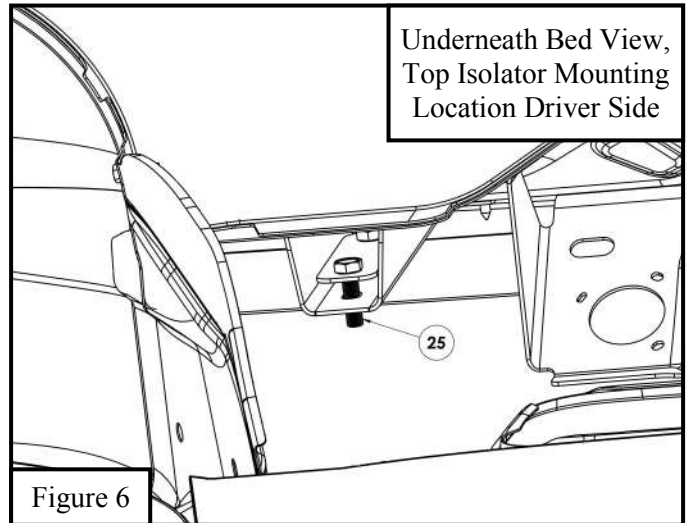

Figure 5

Rear Driver Side Shown



Underneath Bed View, Top Isolator Mounting Location Driver Side

Figure 6

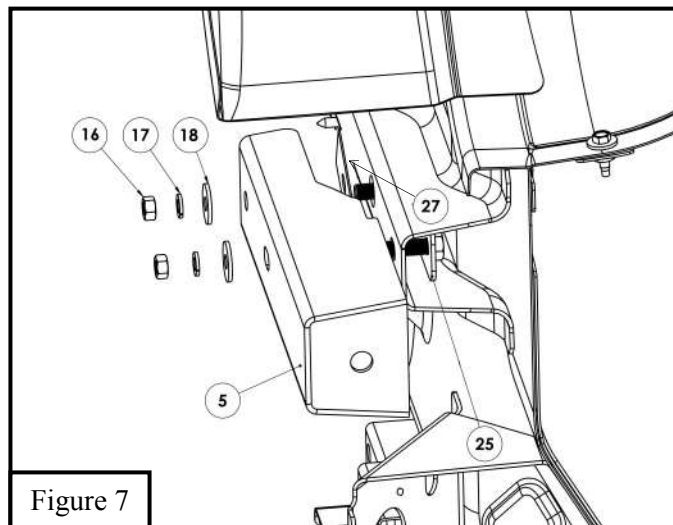
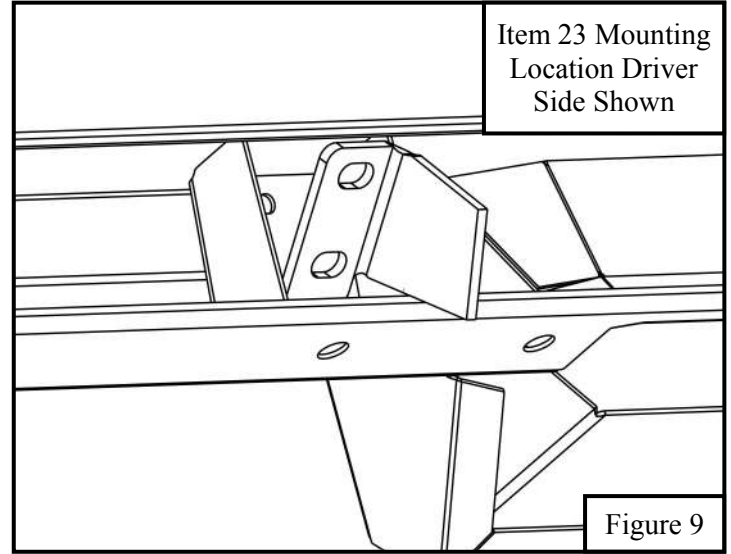
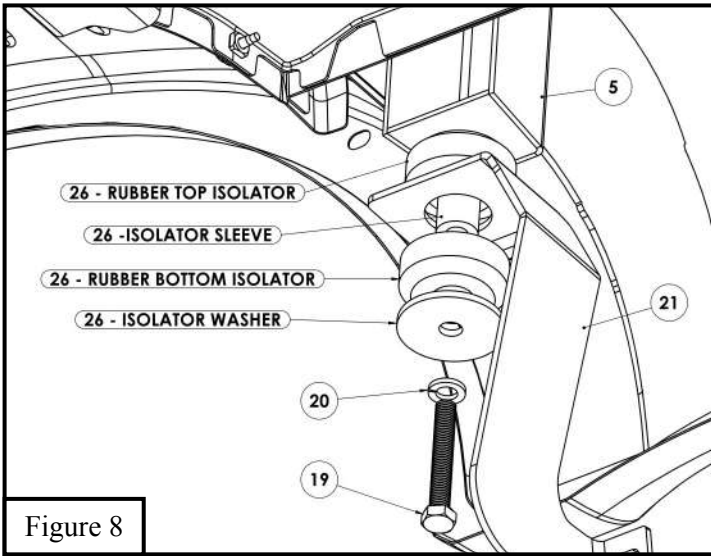

Figure 7

9. Install Bottom Isolator Bracket (Item 21) to previously mounted Top Isolator Bracket (Item 5) with the supplied Isolator Kit (Item 26) and M12 Hardware. Assemble loosely. **See Figure 8**

10. Tilt Board at angle to insert brackets into mounting locations for (Item 23). **See Figure 9**



(NOTE : Reference for bracket locations and orientations can be found in **Figure 12** on **pg. 5**)

11. For Step Board installation to the previously installed mounting brackets use the supplied M8 hardware with short bolts on Mounting Bracket A (Item 23) and use M8 hardware with long bolts for all other mounting location. **See Figure 10 and 11.**

12. Align step bar and brackets to desired positioning then torque and tighten all: M8 hardware to 15-18 ft-lbs, M10 to 32-38 ft-lbs, and M12 to 52-60 ft-lbs.

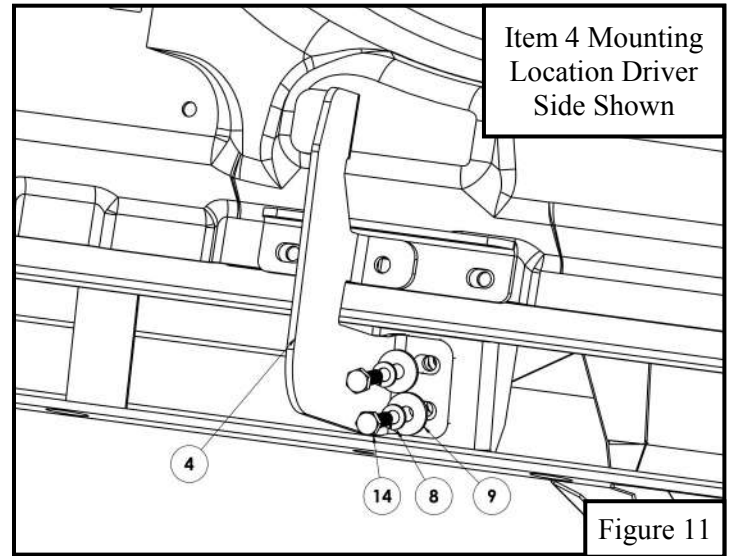
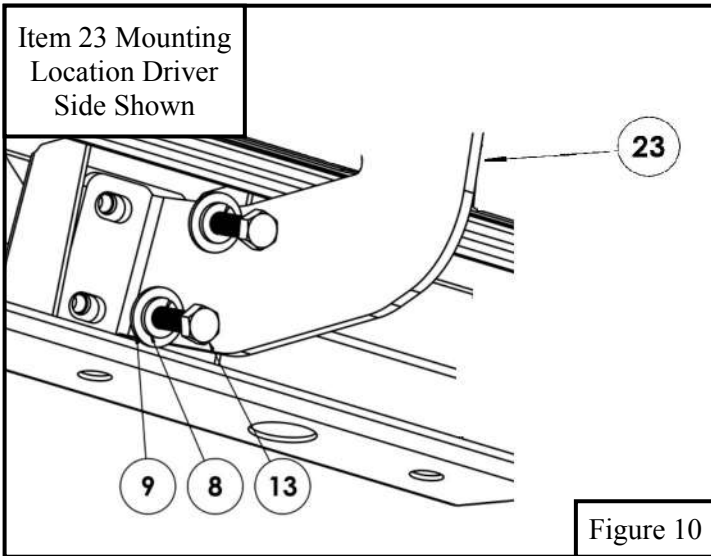
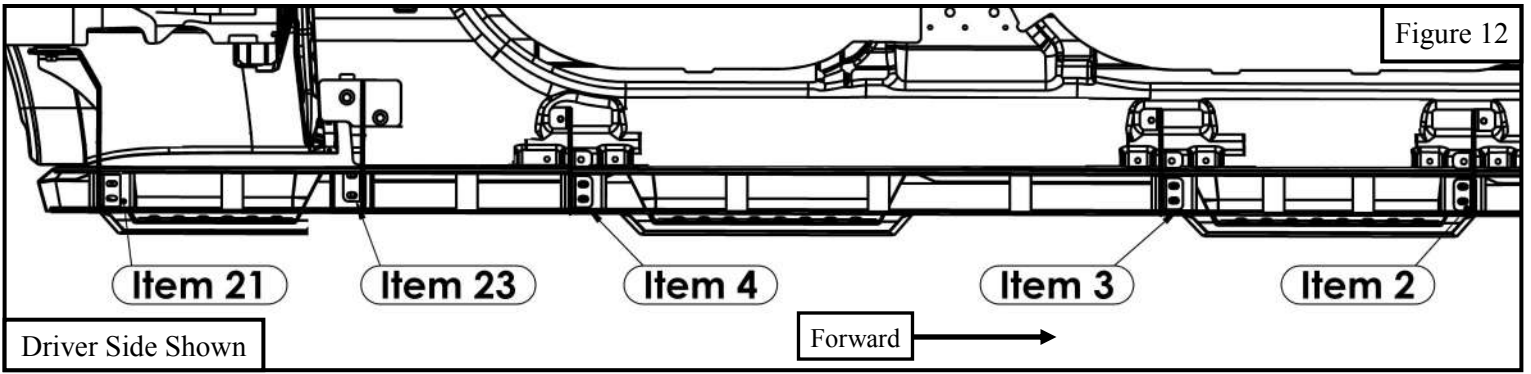

Figure 12



INSTALLATION COMPLETE



Care Instructions

- REGULAR WAXING IS RECOMMENDED. DO NOT USE ANY TYPE OF POLISH OR WAX THAT MAY CONTAIN ABRASIVES.
- STAINLESS STEEL PRODUCTS CAN BE CLEANED WITH MILD SOAP AND WATER. STAINLESS STEEL POLISH SHOULD BE USED TO POLISH SMALL SCRATCHES.
- GLOSS BLACK FINISHES SHOULD BE CLEANED WITH MILD SOAP AND WATER.

Westin

SIGNATURE OF QUALITY

AUTOMOTIVE PRODUCTS, INC.



WARNING



Failure to follow these instructions could lead to death, personal injury, and / or property damage.

FASTENERS:

All Westin supplied fasteners must be utilized and installed in accordance with the installation instructions and apply torque to the specifications as defined. **DOUBLE CHECK ALL FASTENERS BEFORE INITIAL USE, AND PERIODICALLY IN THE FUTURE TO ENSURE PROPER FUNCTION AND SAFETY.**

DRILLING:

Most Westin products do not require drilling for installation. If drilling is defined as required, use caution when drilling a vehicle. **FAILURE TO REVIEW AN AREA TO BE DRILLED MAY RESULT IN PERSONAL INJURY AND/OR INJURY TO OTHERS AS WELL AS VEHICLE DAMAGE.**

EYE PROTECTION:

ALWAYS WEAR SAFETY GLASSES OR GOGGLES DURING THE INSTALLATION PROCESS TO AVOID PERSONAL INJURY.

MAXIMUM TOWING/CARRYING CAPACITY:

The Westin Receiver Hitches will have a visible tow rating label affixed directly on the product. User should never exceed the vehicle manufacturers maximum tow and weight rating regardless of the capacity of the hitch. **FAILURE TO FOLLOW THESE GUIDELINES WILL VOID THE WESTIN WARRANTY AND MAY RESULT IN PERSONAL INJURY AND/OR INJURY TO OTHERS AS WELL AS VEHICLE DAMAGE.**