

# INSTALLATION INSTRUCTIONS

## HDX DROP STEP

AUTOMOTIVE PRODUCTS,

**APPLICATION:**

2005-2015 Toyota Tacoma - Double Cab

**PART NUMBER:**

56-12775

CONTENT			
ITEM	QUANTITY	DESCRIPTION	TOOLS NEEDED
1	2	STEP BAR ASSEMBLY	13MM SOCKET
2	1	FRONT DRIVER SIDE MOUNTING BRACKET	13MM WRENCH
3	4	MOUNTING BRACKET B	RATCHET
4	12	LONG M8 HEX HEAD CAP SCREW (YELLOW ZINC)	TORQUE WRENCH
5	24	M8 SPLIT LOCK WASHER (YELLOW ZINC)	RATCHET EXT.
6	24	M8 FLAT WASHER (YELLOW ZINC)	
7	12	SHORT M8 HEX HEAD CAP SCREW (YELLOW ZINC)	
8	1	FRONT PASSENGER SIDE MOUNTING BRACKET	

**ANTI-SEIZE LUBRICANT MUST BE USED ON ALL STAINLESS STEEL FASTENERS TO PREVENT THREAD DAMAGE AND GALLING**

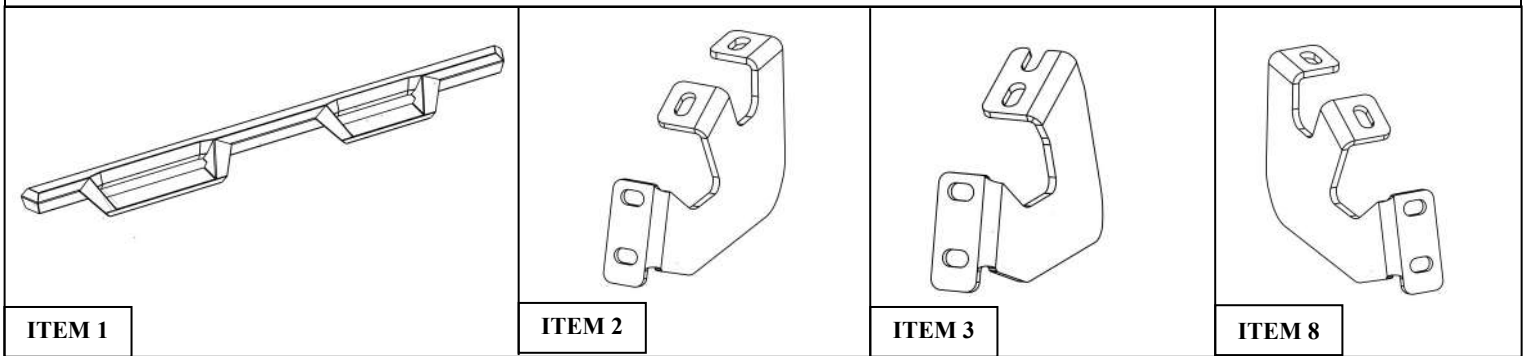

### PROCEDURE

1. Remove contents from box, verify if all parts listed are present and free from damage.  
Carefully read and understand all instructions before attempting installation.  
**Failure to identify damage before installation could lead to a rejection of any claim.**

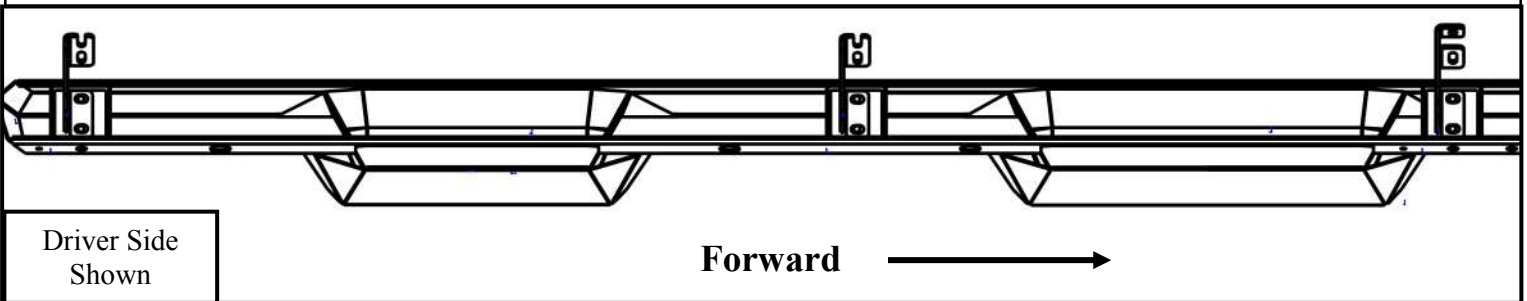

2. Start installation on either side of the vehicle. Locate mounting locations with factory threaded holes with caps covering them. Remove factory caps from threaded holes, they will not be used again. Locate (1) Front Mounting Bracket and loosely install it to the front mounting location on the rocker panel using (2) Long M8 hex head cap screw, (2) M8 split lock washer, and (2) M8 flat washer (Items 4-6). Locate the Mounting Bracket B (Item 3) and loosely secure in the correct mounting locations on the rocker panel. Loosely install using the provided M8 hardware (Items 5-7). **See Figure. 1 and 2.**
3. Repeat Step 2 for the other vehicle side.

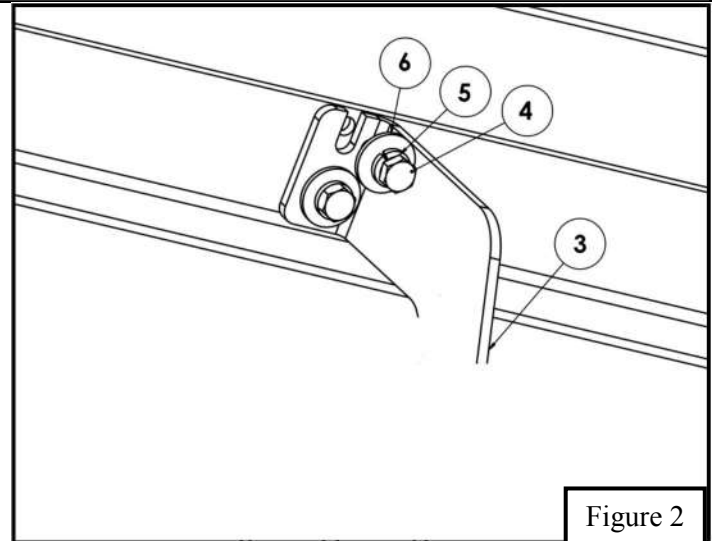
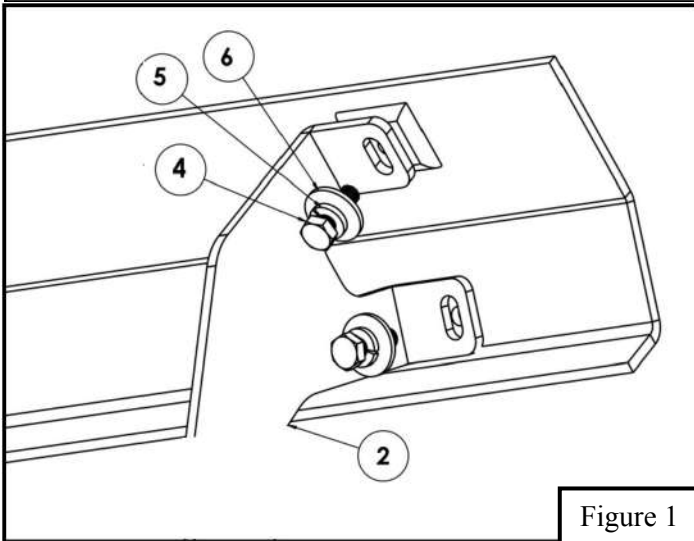

4. For Step Board installation tilt board at angle to mount to brackets. **See Figure 3.**
5. For Step Board installation to the previously installed mounting brackets use the supplied Short M8 bolts and M8 hardware. Slide bolt plate into the board rail located underneath the step board, then loosely install with M8 hardware. **See Figure 4.**
6. Align step board and brackets to desired positioning then torque and tighten all: M8 hardware to 20 ft-lbs.

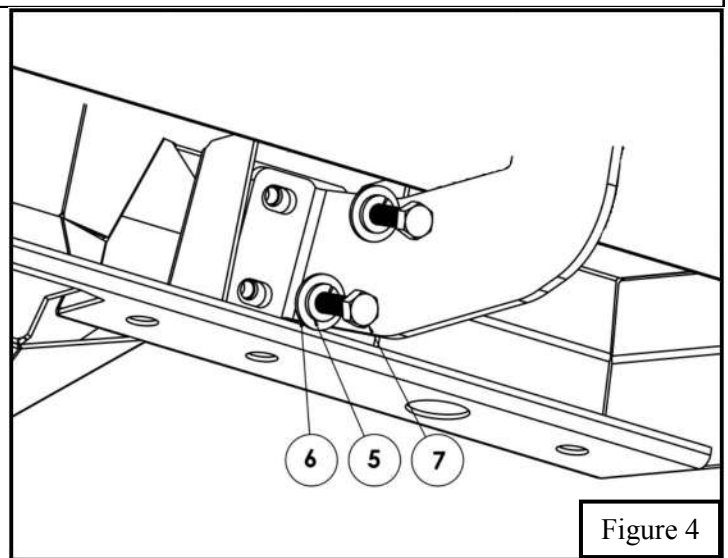
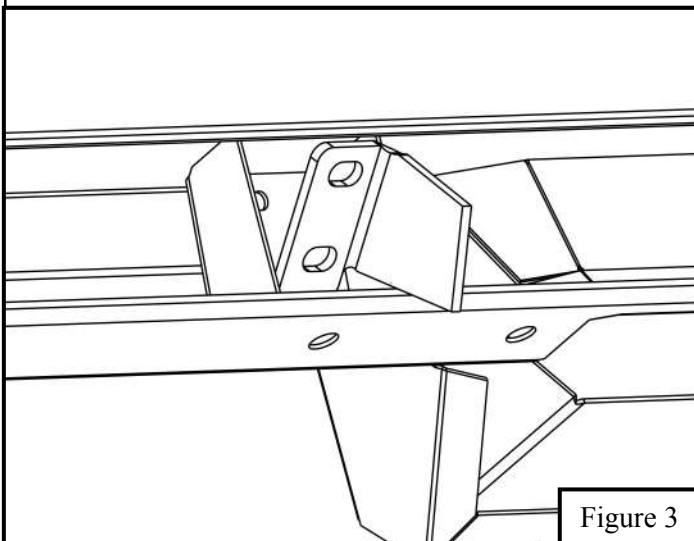

INSTALLATION COMPLETE



#### Care Instructions

- REGULAR WAXING IS RECOMMENDED. DO NOT USE ANY TYPE OF POLISH OR WAX THAT MAY CONTAIN ABRASIVES.
- STAINLESS STEEL PRODUCTS CAN BE CLEANED WITH MILD SOAP AND WATER. STAINLESS STEEL POLISH SHOULD BE USED TO POLISH SMALL SCRATCHES.
- GLOSS BLACK FINISHES SHOULD BE CLEANED WITH MILD SOAP AND WATER.

# Westin

SIGNATURE OF QUALITY

AUTOMOTIVE PRODUCTS, INC.



## WARNING



Failure to follow these instructions could lead to death, personal injury, and / or property damage.

### **FASTENERS:**

All Westin supplied fasteners must be utilized and installed in accordance with the installation instructions and apply torque to the specifications as defined. **DOUBLE CHECK ALL FASTENERS BEFORE INITIAL USE, AND PERIODICALLY IN THE FUTURE TO ENSURE PROPER FUNCTION AND SAFETY.**

### **DRILLING:**

Most Westin products do not require drilling for installation. If drilling is defined as required, use caution when drilling a vehicle. **FAILURE TO REVIEW AN AREA TO BE DRILLED MAY RESULT IN PERSONAL INJURY AND/OR INJURY TO OTHERS AS WELL AS VEHICLE DAMAGE.**

### **EYE PROTECTION:**

**ALWAYS WEAR SAFETY GLASSES OR GOGGLES DURING THE INSTALLATION PROCESS TO AVOID PERSONAL INJURY.**

### **MAXIMUM TOWING/CARRYING CAPACITY:**

The Westin Receiver Hitches will have a visible tow rating label affixed directly on the product. User should never exceed the vehicle manufacturers maximum tow and weight rating regardless of the capacity of the hitch. **FAILURE TO FOLLOW THESE GUIDELINES WILL VOID THE WESTIN WARRANTY AND MAY RESULT IN PERSONAL INJURY AND/OR INJURY TO OTHERS AS WELL AS VEHICLE DAMAGE.**