

# INSTALLATION INSTRUCTIONS

## MUFFLER SKID PLATE



### APPLICATION:

2018-2019 Jeep Wrangler JL 2dr / Wrangler Unlimited 4dr  
(Excl. 2018 JK)

### PART NUMBER:

42-21105

CONTENT			
ITEM	QUANTITY	DESCRIPTION	TOOLS NEEDED
1	1	SKID PLATE	13MM WRENCH
2	2	BRACKET A	16MM SOCKET
3	1	BRACKET B	ALLEN WRENCH
4	1	BRACKET C	RATCHET
5	1	M10 NUT PLATE	TORQUE WRENCH
6	4	PLASTIC RETAINER SQUARE	
7	4	M8 SPLIT LOCK WASHER	
8	4	M8 FLAT WASHER	
9	4	M8 HEX NUT	
10	4	M8 SQUARE NECK BOLT	
11	2	M10 BUTTON HEAD SCREW	
12	2	M10 HEX HEAD CAP SCREW	
13	4	M10 SPLIT LOCK WASHER	
14	4	M10 FLAT WASHER	

**ANTI-SEIZE LUBRICANT MUST BE USED ON ALL STAINLESS STEEL FASTENERS TO PREVENT THREAD DAMAGE AND GALLING**

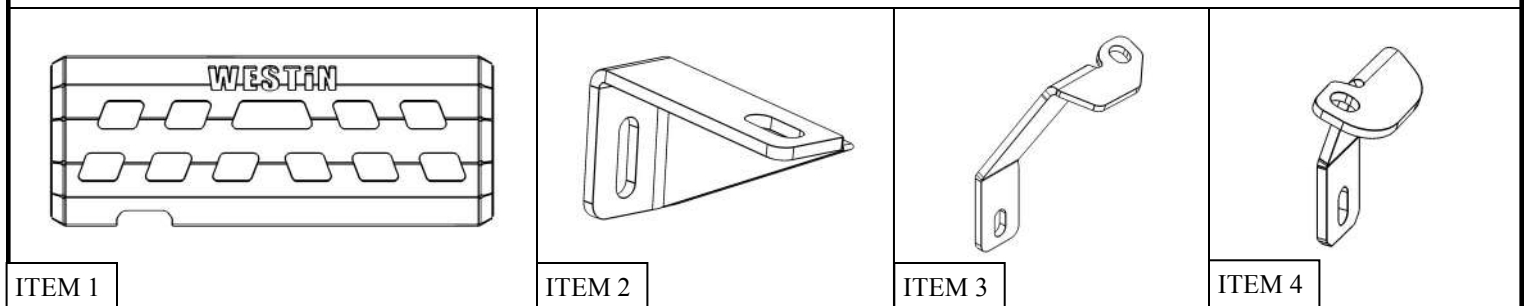

### PROCEDURE

1. Remove contents from box, verify if all parts listed are present and free from damage.  
Carefully read and understand all instructions before attempting installation.  
**Failure to identify damage before installation could lead to a rejection of any claim.**

- Loosely install Bracket C (4) to the Driver Side sway bar using the supplied M10 Hex Bolt (12), M10 Lock washer (13), and M10 Flat Washer (14). See **Figure 1**. *Note: Figures 1-4 show Skid Plate (1) installed. Do not install until Step 6.*
- Repeat **Step 2** on the Passenger Side using Bracket B (3). See **Figure 2**.

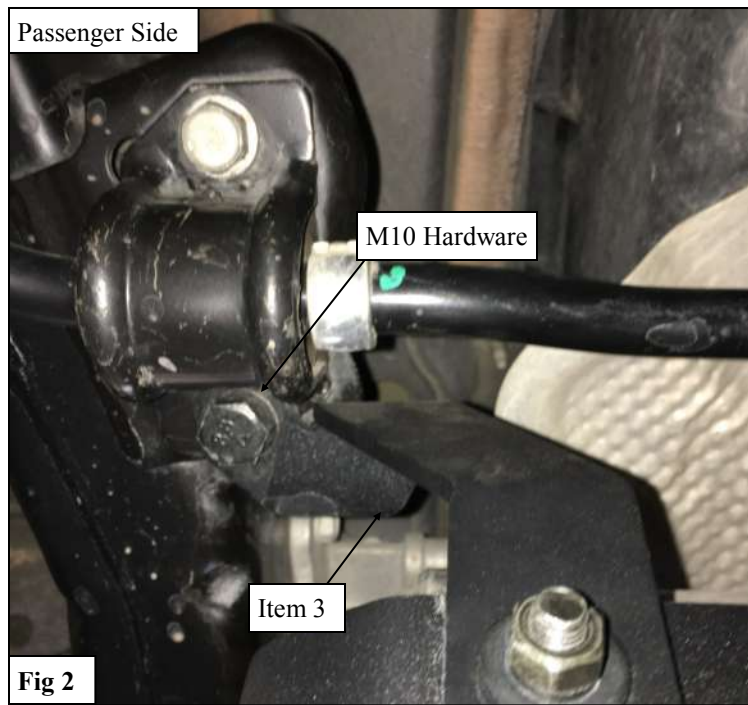
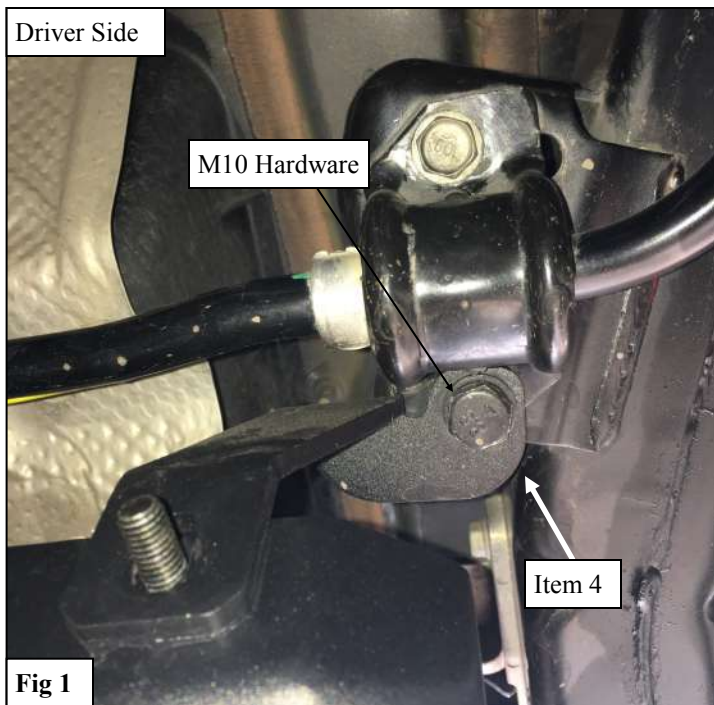

- Loosely install Bracket A (2) to the Driver Side rear of the frame using the supplied M10 Button Head Bolt (11), M10 Lock washer (13), and M10 Flat Washer (14). See **Figure 3**.
- Repeat **Step 4** on the Passenger Side. See **Figure 4**. *Note: The supplied Nut Plate (5) will be inserted into the frame to be used in securing Bracket A (2).*

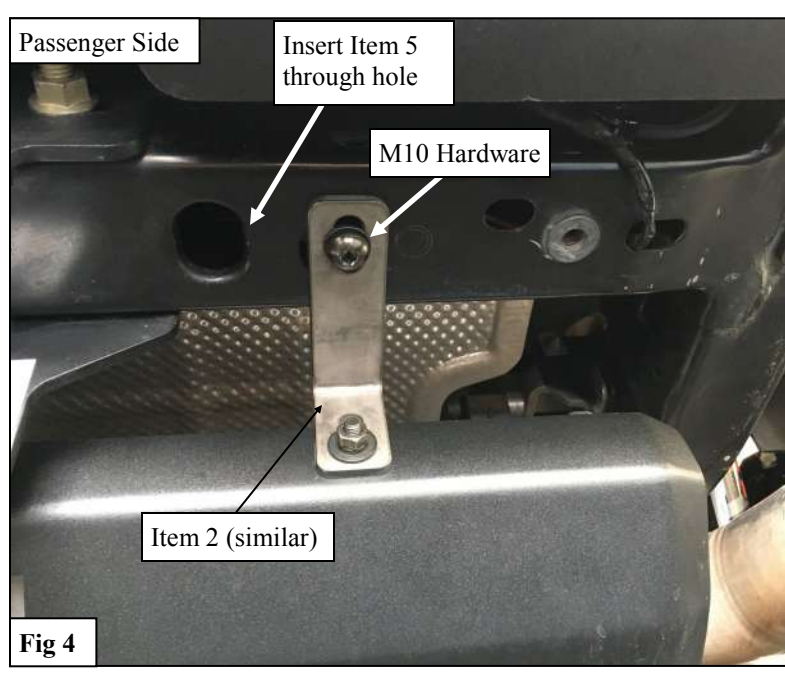
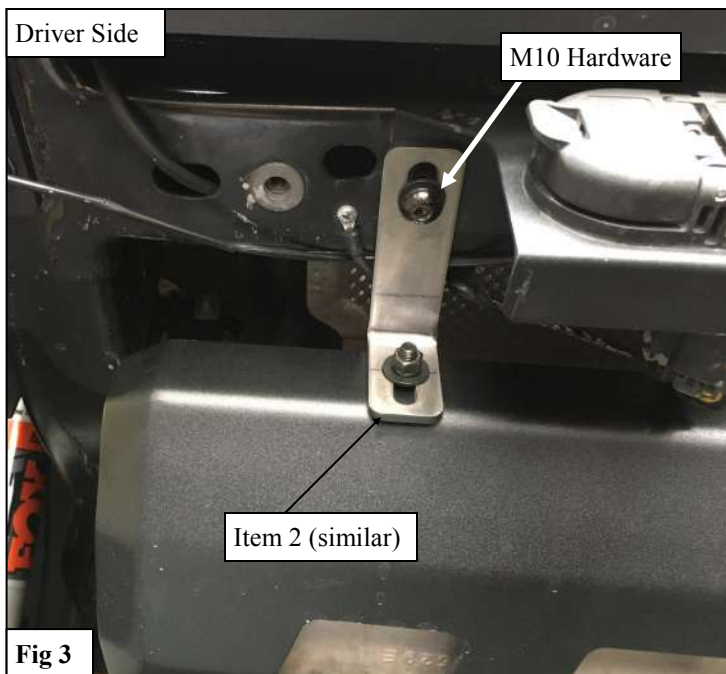

6. Secure the Skid Plate (1) to the Brackets (2-4) using the supplied M8 Hardware. All 4 brackets will fasten to the Skid Plate (1) the same way as seen in **Figure 5**. *Note: See **Figure 6** for bracket positions on the skid plate.*
7. Torque all hardware: M8 hardware to 18 ft-lbs, M10 hardware to 38 ft-lbs.

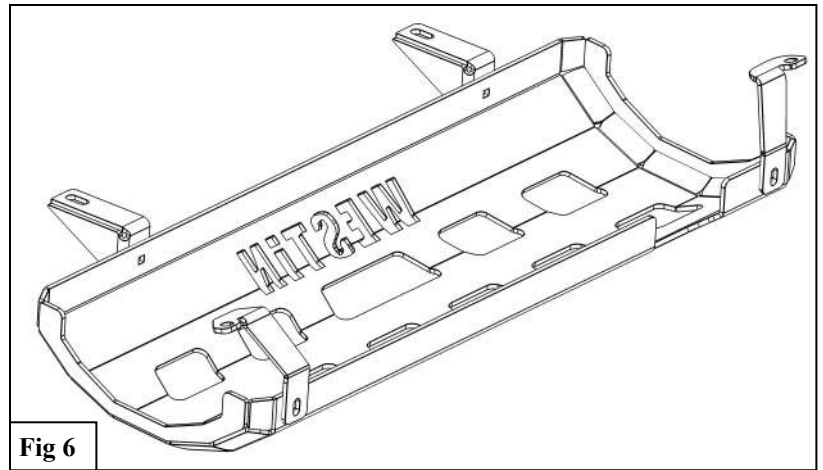
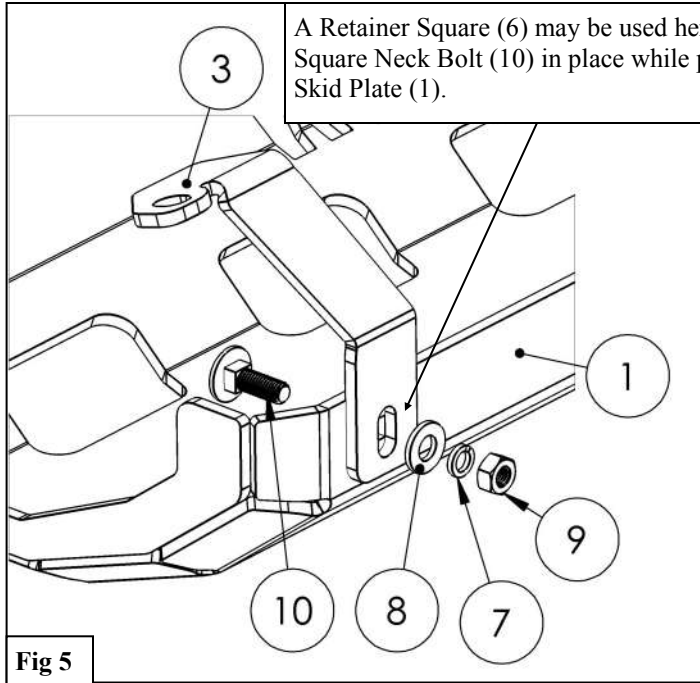

#### CARE INSTRUCTIONS

- REGULAR WAXING IS RECOMMENDED. DO NOT USE ANY TYPE OF POLISH OR WAX THAT MAY CONTAIN ABRASIVES.
- STAINLESS STEEL PRODUCTS CAN BE CLEANED WITH MILD SOAP AND WATER. STAINLESS STEEL POLISH SHOULD BE USED TO POLISH SMALL SCRATCHES.
- GLOSS BLACK FINISHES SHOULD BE CLEANED WITH MILD SOAP AND WATER



## WARNING



Failure to follow these instructions could lead to death, personal injury, and / or property damage.

Failure to follow these instructions could lead to death, personal injury, and / or property damage.

### FASTENERS:

All Westin supplied fasteners must be utilized and installed in accordance with the installation instructions and apply torque to the specifications as defined. **DOUBLE CHECK ALL FASTENERS BEFORE INITIAL USE, AND PERIODICALLY IN THE FUTURE TO ENSURE PROPER FUNCTION AND SAFETY.**

### DRILLING:

Most Westin products do not require drilling for installation. If drilling is defined as required, use caution when drilling a vehicle. **FAILURE TO REVIEW AN AREA TO BE DRILLED MAY RESULT IN PERSONAL INJURY AND/OR INJURY TO OTHERS AS WELL AS VEHICLE DAMAGE.**

### EYE PROTECTION:

**ALWAYS WEAR SAFETY GLASSES OR GOGGLES DURING THE INSTALLATION PROCESS TO AVOID PERSONAL INJURY.**

### MAXIMUM TOWING/CARRYING CAPACITY: (if applicable)

The Westin Receiver Hitches will have a visible tow rating label affixed directly on the product. User should never exceed the vehicle manufacturers maximum tow and weight rating regardless of the capacity of the hitch. **FAILURE TO FOLLOW THESE GUIDELINES WILL VOID THE WESTIN WARRANTY AND MAY RESULT IN PERSONAL INJURY AND/OR INJURY TO OTHERS AS WELL AS VEHICLE DAMAGE.**