



# INSTALLATION INSTRUCTIONS

Thrasher Board

**APPLICATION:**  
2016 Nissan Titan Crew Cab

AUTOMOTIVE PRODUCTS,

**PART NUMBER:**  
28-81165

CONTENT			
ITEM	QUANTITY	DESCRIPTION	TOOLS NEEDED
1	2	STEP BAR ASSEMBLY	RATCHET
2	3	MOUNTING BRACKET A	TORQUE WRENCH
3	3	MOUNTING BRACKET B	13MM SOCKET
4	6	PLASTIC BRACKET COVER	10MM SOCKET
5	12	M6 HEX HEAD CAP SCREW (YELLOW ZINC)	10MM WRENCH
6	24	M6 FLAT WASHER (YELLOW ZINC)	
7	12	M6 NYLON LOCK NUT (YELLOW ZINC)	
8	12	M8 HEX HEAD CAP SCREW (BLACK ZINC) <b>SEMS HARDWARE</b>	
9	12	M8 SPLIT LOCK WASHER (BLACK ZINC) <b>SEMS HARDWARE</b>	
10	12	M8 LARGE FLAT WASHER (BLACK ZINC) <b>SEMS HARDWARE</b>	
11	12	M8 HEX NUT (BLACK ZINC)	
12	12	M8 SPLIT LOCK WASHER (BLACK ZINC)	
13	12	M8 FLAT WASHER (BLACK ZINC)	
14	6	M8 BOLT PLATE (BLACK ZINC)	

**ANTI-SEIZE LUBRICANT MUST BE USED ON ALL STAINLESS STEEL FASTENERS TO PREVENT THREAD DAMAGE AND GALLING**

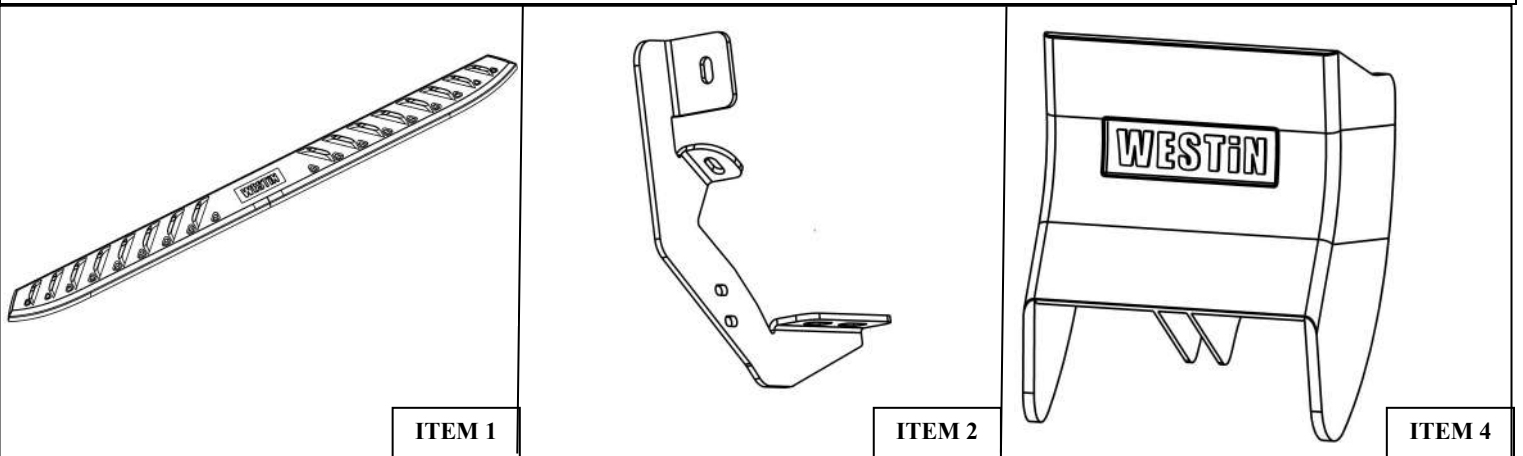

ITEM 1

ITEM 2

ITEM 4

## PROCEDURE

1. Remove contents from box, verify if all parts listed are present and free from damage.  
Carefully read and understand all instructions before attempting installation.  
**Failure to identify damage before installation could lead to a rejection of any claim.**



2. Start installation on driver's side. On the rocker panel find locations with threaded holes.
3. Then loosely install SEMS hardware to threaded holes with; (2) M8 hex head bolts, (2) M8 flat washers, (2) M8 split lock washers. **See Figure 1.**
4. Locate (1) Plastic Bracket Cover (Item 4) and loosely secure it to the (6) brackets using the provided hardware: (2) M6 hex head bolt, (4) M6 flat washer, and (2) M6 nylon lock nut. Repeat for every bracket. **See Figure 2.**

Figure 1

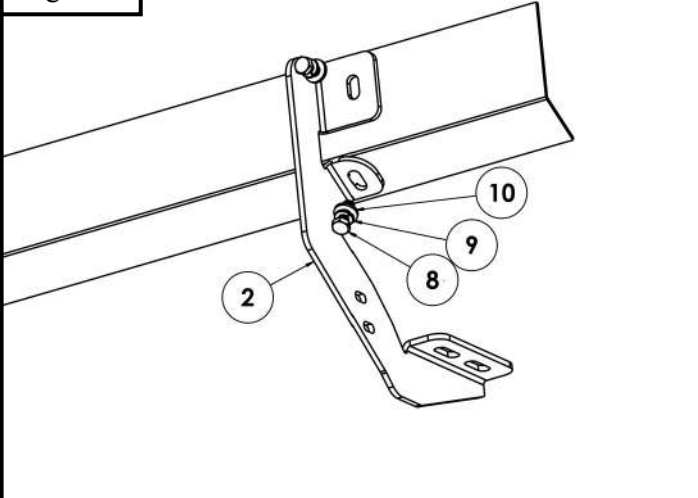
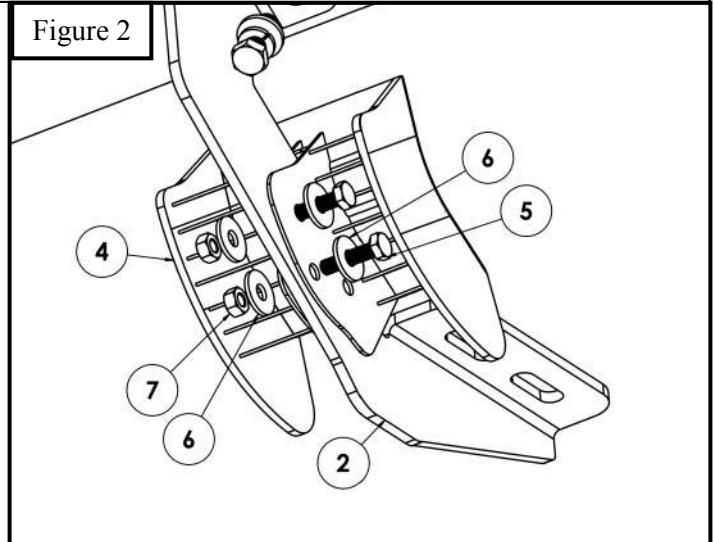

Figure 2



5. For Step Board installation to the previously installed mounting brackets use the supplied M8 bolt plates and M8 hardware. Slide bolt plate into the board rail located underneath the step board, then loosely install with M8 hardware. **See Figure 3 and Figure 4.**
6. Align step bar and brackets to desired positioning then torque and tighten all: M8 hardware to 20 ft-lbs and M6 hardware to 12 ft-lbs.

Figure 3

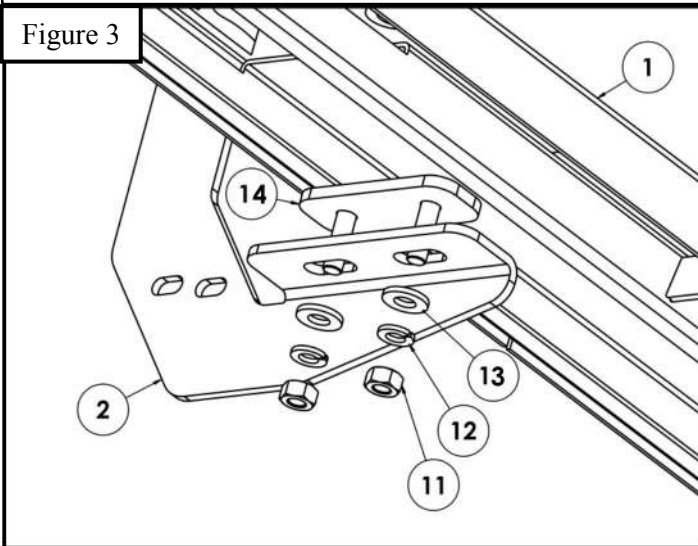
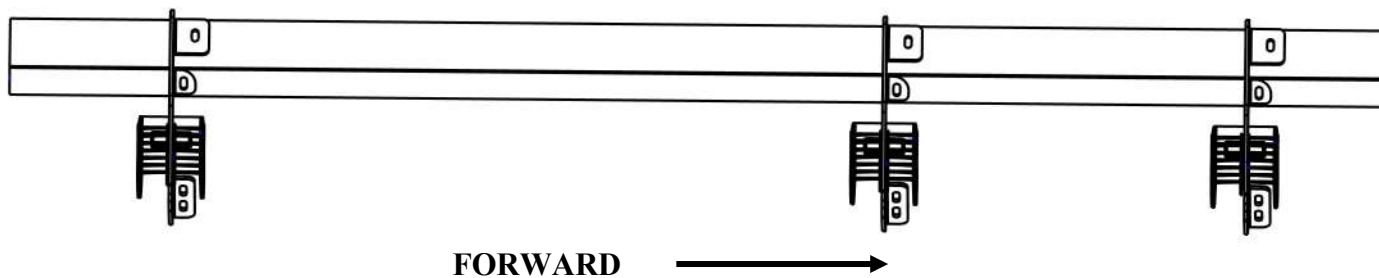

Figure 4



INSTALLATION COMPLETED



#### Care Instructions

- REGULAR WAXING IS RECOMMENDED. DO NOT USE ANY TYPE OF POLISH OR WAX THAT MAY CONTAIN ABRASIVES.
- STAINLESS STEEL PRODUCTS CAN BE CLEANED WITH MILD SOAP AND WATER. STAINLESS STEEL POLISH SHOULD BE USED TO POLISH SMALL SCRATCHES..
- GLOSS BLACK FINISHES SHOULD BE CLEANED WITH MILD SOAP AND WATER.

# Westin

SIGNATURE OF QUALITY

AUTOMOTIVE PRODUCTS, INC.



## WARNING



Failure to follow these instructions could lead to death, personal injury, and / or property damage.

### **FASTENERS:**

All Westin supplied fasteners must be utilized and installed in accordance with the installation instructions and apply torque to the specifications as defined. **DOUBLE CHECK ALL FASTENERS BEFORE INITIAL USE, AND PERIODICALLY IN THE FUTURE TO ENSURE PROPER FUNCTION AND SAFETY.**

### **DRILLING:**

Most Westin products do not require drilling for installation. If drilling is defined as required, use caution when drilling a vehicle. **FAILURE TO REVIEW AN AREA TO BE DRILLED MAY RESULT IN PERSONAL INJURY AND/OR INJURY TO OTHERS AS WELL AS VEHICLE DAMAGE.**

### **EYE PROTECTION:**

**ALWAYS WEAR SAFETY GLASSES OR GOGGLES DURING THE INSTALLATION PROCESS TO AVOID PERSONAL INJURY.**

### **MAXIMUM TOWING/CARRYING CAPACITY:**

The Westin Receiver Hitches will have a visible tow rating label affixed directly on the product. User should never exceed the vehicle manufacturers maximum tow and weight rating regardless of the capacity of the hitch. **FAILURE TO FOLLOW THESE GUIDELINES WILL VOID THE WESTIN WARRANTY AND MAY RESULT IN PERSONAL INJURY AND/OR INJURY TO OTHERS AS WELL AS VEHICLE DAMAGE.**