



AUTOMOTIVE PRODUCTS,

# INSTALLATION INSTRUCTIONS

**PROTRAXX 5 WTW**

**APPLICATION:**

**2017 Ford F-250/350 Crew Cab 8ft Bed**

**2017 Ford F-250/350 Super Cab 8ft Bed**

**PART NUMBER:**

**21-534655, 21-534675**

ITEM	QUANTITY	DESCRIPTION	TOOLS NEEDED
1,2	2	STEP BARS, DRIVER (1) AND PASSENGER (2)	13MM SOCKET
3,4	2	ISOLATOR BRACKET, DRIVER (3) AND PASSENGER (4)	13MM WRENCH
5	2	ISOLATOR SUPPORT BRACKET	10MM SOCKET
6	2	MOUNT BRACKET A	10MM WRENCH
7	2, 4*	MOUNT BRACKET B	18MM SOCKET
8	4, 6*	UNIVERSAL MOUNT BRACKET	HEX KEY TOOL
9	6, 8*	PLASTIC BRACKET COVER	RATCHET
10	2	M10 DOUBLE BOLT PLATE	TORQUE WRENCH
11	2	ISOLATOR KIT	
12	16, 24*	M8 HEX NUT (YELLOW ZINC)	
13	16, 24*	M8 FLAT WASHER (YELLOW ZINC)	
14	16, 24*	M8 SPLIT LOCK WASHER (YELLOW ZINC)	
15	4	M10 HEX NUT (YELLOW ZINC)	
16	4	M10 FLAT WASHER (YELLOW ZINC)	
17	4	M10 SPLIT LOCK WASHER (YELLOW ZINC)	
18	4, 6*	M8 ROUND HEAD SQUARE NECK BOLT (YELLOW ZINC)	
19	12, 16*	M6 HEX HEAD CAP SCREW (YELLOW ZINC)	
20	24, 32*	M6 FLAT WASHER (YELLOW ZINC)	
21	12, 16*	M6 NYLOCK NUT (YELLOW ZINC)	
22	2	M12 HEX HEAD CAP SCREW (YELLOW ZINC)	
23	2	M12 SPLIT LOCK WASHER (YELLOW ZINC)	
24	12, 16*	M10 HEX SOCKET BUTTON HEAD CAP SCREW (BLACK ZINC)	
25	12, 16*	M10 INTERNAL TOOTHED LOCK WASHER (BLACK ZINC)	
26	12, 16*	M10 FLAT WASHER (BLACK ZINC)	
27	12, 18*	M8 PLASTIC RETAINER SQUARE	
28	4	M10 PLASTIC RETAINER SQUARE	

**\* CREW CAB HAS (2) EXTRA MOUNT BRACKET B, (2) EXTRA BRACKET PLASTIC COVERS, AND EXTRA HARDWARE.**

**ANTI-SEIZE LUBRICANT MUST BE USED ON ALL STAINLESS STEEL FASTENERS TO PREVENT THREAD DAMAGE AND GALLING**

### Care Instructions

- REGULAR WAXING IS RECOMMENDED. DO NOT USE ANY TYPE OF POLISH OR WAX THAT MAY CONTAIN ABRASIVES.
- STAINLESS STEEL PRODUCTS CAN BE CLEANED WITH MILD SOAP AND WATER. STAINLESS STEEL POLISH SHOULD BE USED TO POLISH SMALL SCRATCHES.
- GLOSS BLACK FINISHES SHOULD BE CLEANED WITH MILD SOAP AND WATER.

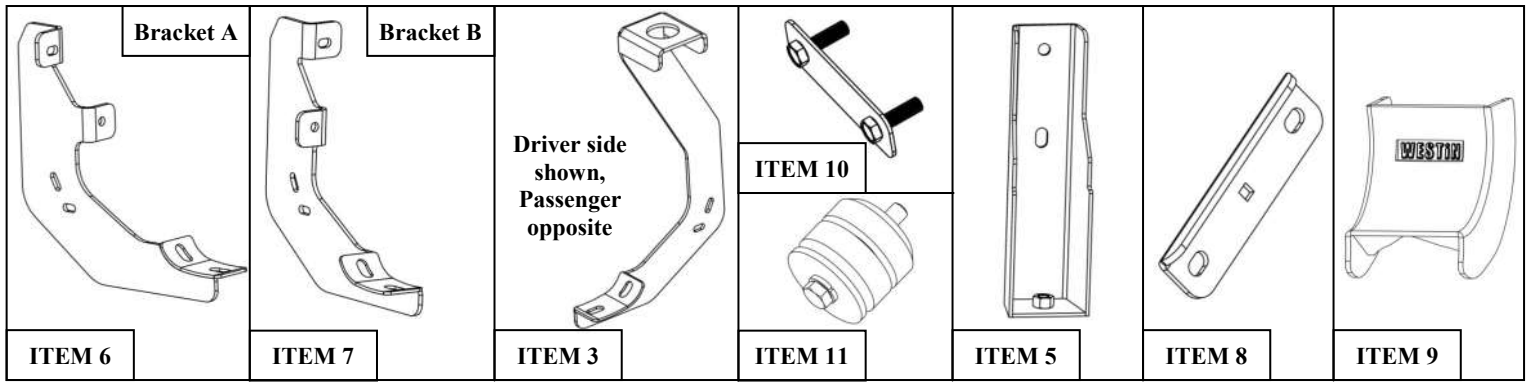

### PROCEDURE

- Remove contents from box, verify if all parts listed are present and free from damage. Carefully read and understand all instructions before attempting installation.  
**Failure to identify damage before installation could lead to a rejection of any claim.**
- Start installation on driver's side. On the rocker panel find locations of factory studs. In each location there should be 3 studs. **Note:** Super Cab has two mount locations and Crew Cab has three mount locations. See **Figure 1**.
- Insert (1) M8 Plastic Retainer (Item 27) on each factory stud. **Note:** There will be 6 extra plastic retainers for the super cab model. See **Figure 2**.

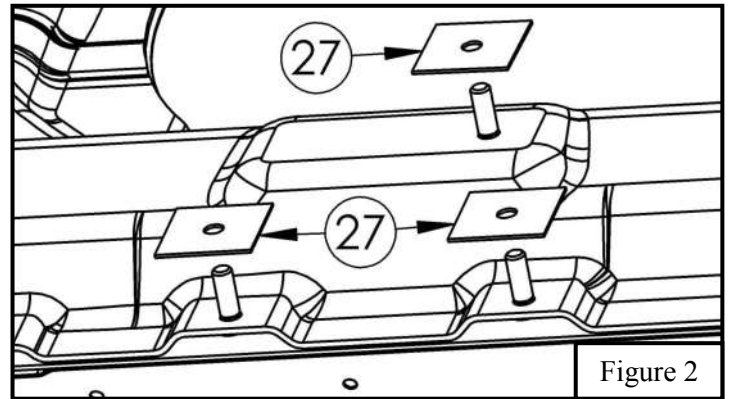
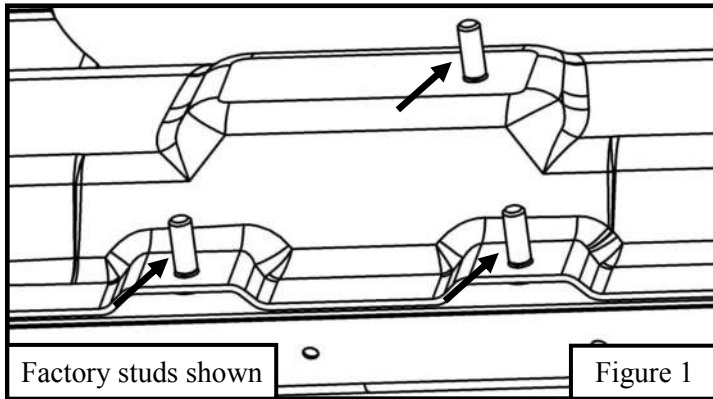

- Insert the M8 round head square neck bolt (Item 18) through the Universal Mount Bracket's (Item 8) square hole. Then insert the M8 round head square neck bolt through mounting brackets bottom circular hole. Loosely secure with (1) M8 hex nut, (1) M8 split lock washer, and (1) M8 flat washer. **Note:** For Super Cab model there will be 4 Universal Mounting Brackets and for the Super Crew model there are 6. See **Figure 3**.
- Align sub-assembly with the 3 factory studs. Lower 2 factory studs will align with the Universal Mount Bracket and top factory stud will align with mounting brackets. Loosely secure sub-assembly with (3) M8 hex nut, (3) M8 split lock washer, and (3) M8 flat washer. See **Figure 4**.
- Repeat **Step 3 - 5** for every mounting location. **Note:** Isolator bracket is installed differently. See **Steps 7 - 9**.

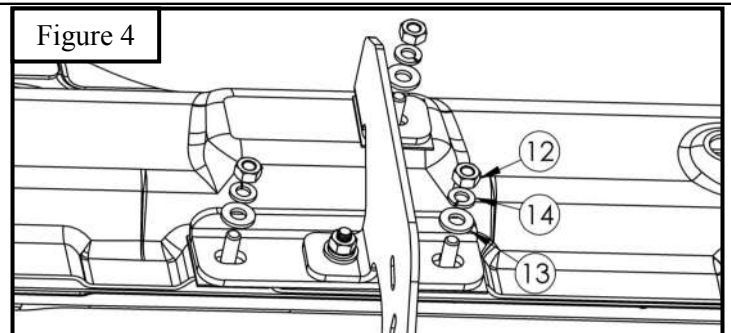
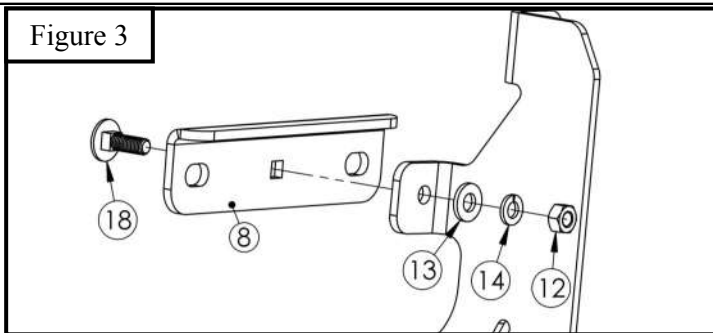

7. Locate the isolator mounting location, located near the rear tire. Insert (1) M10 double bolt plate (Item 10) into frame and insert (2) M10 plastic retainer squares (Item 28) through both bolts in order to prevent bolt plate from falling. See **Figure 5**.
8. Locate (1) isolator support bracket (Item 5) and loosely secure onto M10 double bolt plate using (2) M10 hex nuts, (2) M10 flat washers, and (2) M10 split lock washer. See **Figure 6**.
9. Locate (1) isolator bracket (Item 3/4) and isolator kit (Item 11) and loosely secure onto previously installed isolator support bracket. See **Figure 7**.
10. Locate (1) plastic bracket cover (Item 9) and loosely secure it to the brackets using the provided hardware: (2) M6 hex head cap screws, (4) M6 flat washers, and (2) M6 nylon nuts. Repeat for every bracket. See **Figure 8**.
11. For step bar installation to the previously installed mounting brackets use the supplied M10 hardware. See **Figure 9**.

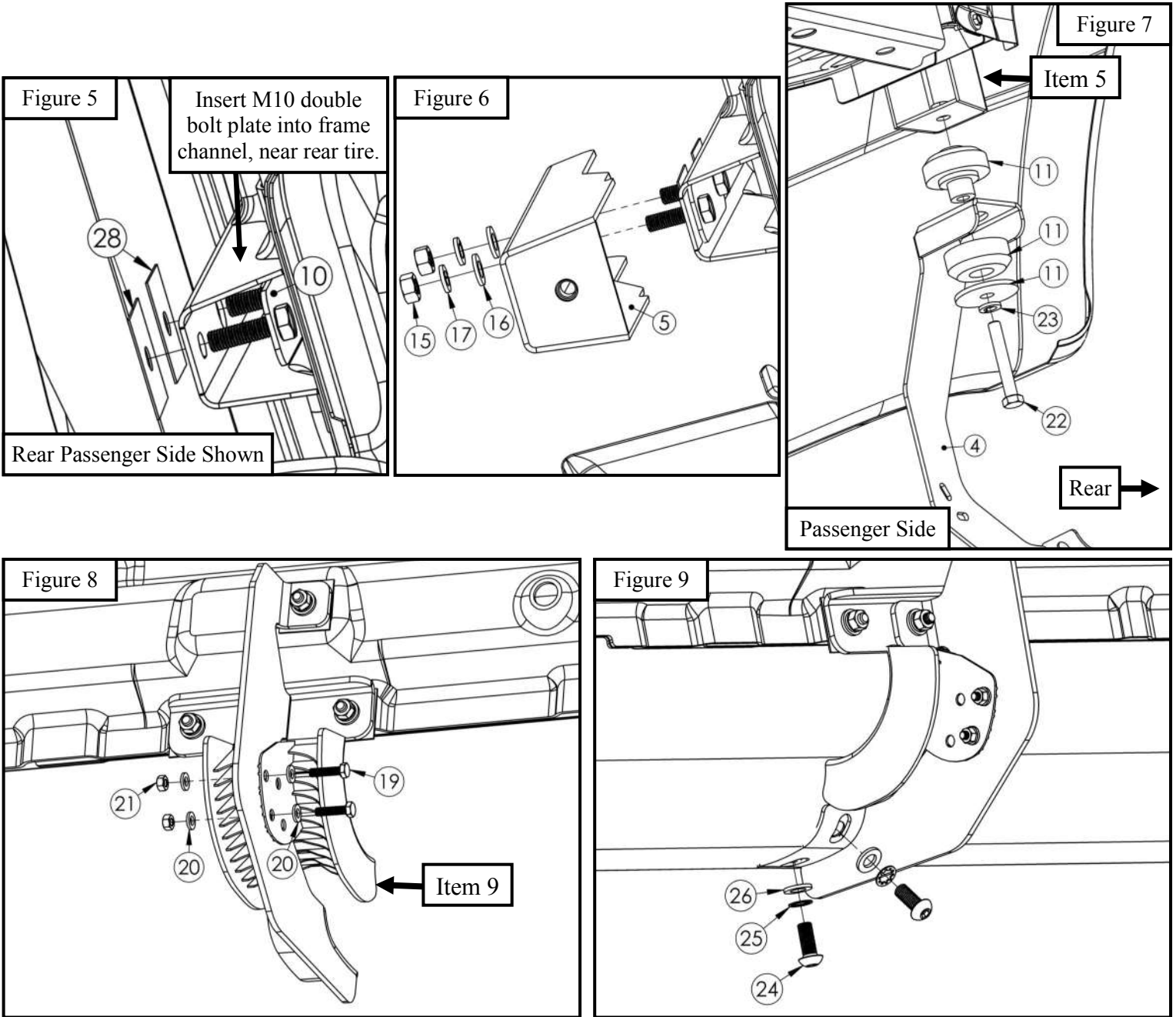



# Westin

SIGNATURE OF QUALITY

AUTOMOTIVE PRODUCTS, INC.



## WARNING



Failure to follow these instructions could lead to death, personal injury, and / or property damage.

### FASTENERS:

All Westin supplied fasteners must be utilized and installed in accordance with the installation instructions and apply torque to the specifications as defined. **DOUBLE CHECK ALL FASTENERS BEFORE INITIAL USE, AND PERIODICALLY IN THE FUTURE TO ENSURE PROPER FUNCTION AND SAFETY.**

### DRILLING:

Most Westin products do not require drilling for installation. If drilling is defined as required, use caution when drilling a vehicle. **FAILURE TO REVIEW AN AREA TO BE DRILLED MAY RESULT IN PERSONAL INJURY AND/OR INJURY TO OTHERS AS WELL AS VEHICLE DAMAGE.**

### EYE PROTECTION:

**ALWAYS WEAR SAFETY GLASSES OR GOGGLES DURING THE INSTALLATION PROCESS TO AVOID PERSONAL INJURY.**

### MAXIMUM TOWING/CARRYING CAPACITY:

The Westin Receiver Hitches will have a visible tow rating label affixed directly on the product. User should never exceed the vehicle manufacturers maximum tow and weight rating regardless of the capacity of the hitch. **FAILURE TO FOLLOW THESE GUIDELINES WILL VOID THE WESTIN WARRANTY AND MAY RESULT IN PERSONAL INJURY AND/OR INJURY TO OTHERS AS WELL AS VEHICLE DAMAGE.**