

240029

REPLACEMENT PARTS LIST

1	053384	WELDMNT: DOLLY (D3)	1
2	055249	CASTER: SET 3" HR W/ ZINC RIG	1

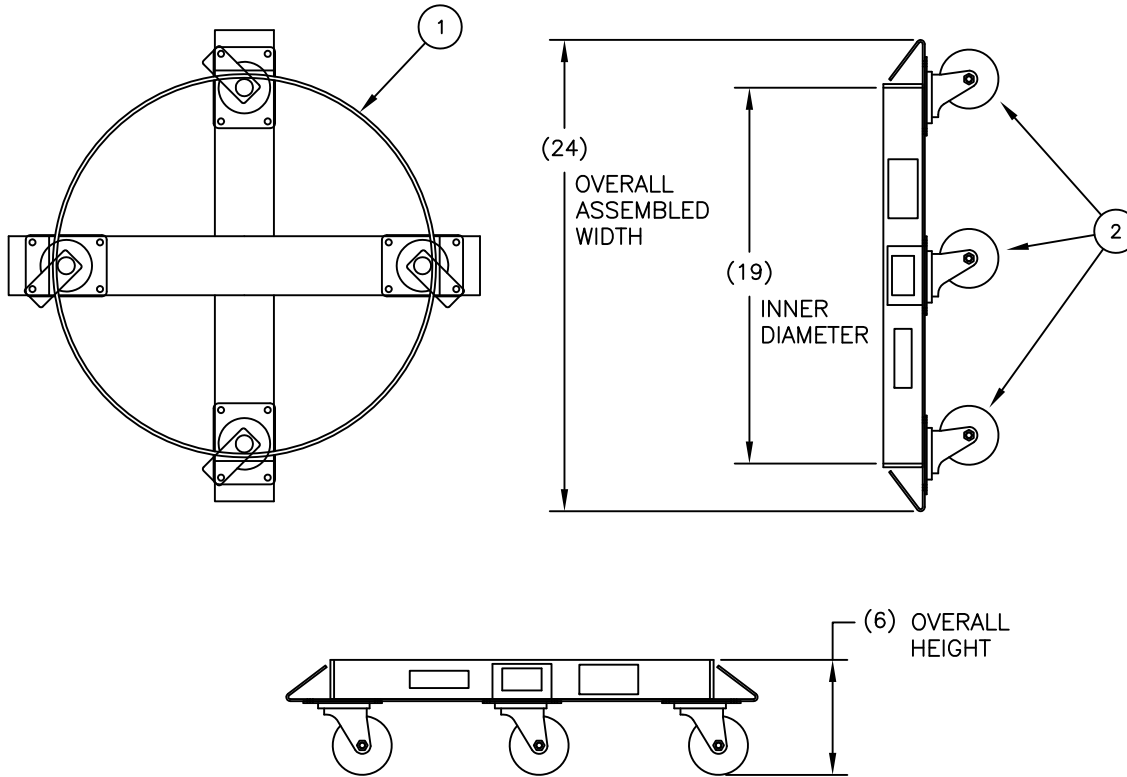

STEEL DRUM DOLLIES

- Superior design places drum chime over caster kingpin for greater load stability and long cater life.
- All welded steel frame construction with reinforced outriggers.
- Four bolt on 3" swivel casters.
- I.D. varies among models.
- Model available for 30, 55, and 85 gallon drums.

P/N 240029

Model: D3-HR  
 Capacity: 900 lbs  
 Weight: 18 lbs  
 Unit I.D.: 19"  
 Drum size: 30 gal.  
 Caster Type: Hard Rubber  
 Box: Yes

THIS DRAWING IN ALL PARTICULARS IS WESCO INDUSTRIAL PRODUCTS INC. PROPERTY. ALL RIGHTS OF DESIGN, INVENTION OR USE OF ARE RESERVED.

<p>PRINT ISSUED</p> <p>NOV. 15, 2006</p> <p>WESCO MANUFACTURING ENGINEERING DEPARTMENT</p>	R W S	APP	<p>WESCO INDUSTRIAL PRODUCTS INC.</p> <p>NORTH WALES PENNA. 19454</p>							
	11-08-12									
	UPDATED PARTS LIST	ECN & DATE	<p>PART NAME</p> <p><b>D3-HR</b></p> <p>DRUM DOLLIES</p>							
		REV.	<p>TOLERANCE UNLESS OTHERWISE SPECIFIED</p> <table border="1"> <tr> <td>FRACTION</td> <td>3 PLACE DECIMAL</td> <td>2 PLACE DECIMAL</td> </tr> <tr> <td>± 1/64</td> <td>± .005</td> <td>± .01</td> </tr> </table>		FRACTION	3 PLACE DECIMAL	2 PLACE DECIMAL	± 1/64	± .005	± .01
FRACTION	3 PLACE DECIMAL	2 PLACE DECIMAL								
± 1/64	± .005	± .01								
			<p>SCALE: 1" = 8"</p>							
			<p>ANGULAR ± 1-1/2' SHEET 1 OF 1</p>							
			<p>BREAK ALL SHARP EDGES AND REMOVE ALL BURRS</p>							
			<p>A-240029 REV C</p>							

Looking for dependable service carts? Rely on Wesco Industrial for quality and long-lasting products.